

**Cast iron solutions
that contribute to the comfort,
safety and durability of buildings**



**SAFE AND
SUSTAINABLE
BY NATURE**

CONTENTS

BUILDING SOLUTIONS & REFERENCES | 9

OUR SERVICES | 21

WHY USE CAST IRON? | 33

OUR SOLUTIONS | 65

PRODUCT CATALOG | 85

Wastewater | 86

Domestic use: PAM-GLOBAL® S – 86

Intensive use: PAM-GLOBAL® Plus & SMU Zn – 108

Rainwater | 122

Gravity system: Residential Type R – 122

Siphonic system: EPAMS® – 128

Infrastructure | 130

Itinero® – 130

Couplings, collars & connectors | 134

Supporting & fixing systems | 142

Accessories | 145

DESIGN & INSTALLATION | 147

GENERAL TERMS & CONDITIONS OF SALE | 183

PAM BUILDING, COMMITTED TO SUSTAINABILITY AND PRODUCT EXCELLENCE



For 150 years, we have been designing, manufacturing and supplying high-quality drainage systems for residential and commercial buildings and engineering structures.

We work exclusively with cast iron, a noble and durable material, of which we are a specialist and leader.

- > **As a leading manufacturer**, we claim excellence in our processes, products and services.
- > **As a responsible manufacturer**, we are at the forefront of sustainable performance to ensure we make the world a better home.
- > **As an innovative manufacturer**, we put all our creative audacity into developing new, more specific and more efficient technologies, to deliver better products for your future needs.

PAM Building, a company built on the strength of its people, established in 3 major countries: **France, England and Germany**, and servicing the world

Over **360 employees**

Sales in more than **50 countries**

2 manufacturing sites for our products: **Bayard sur Marne** in France **Telford** in England

1st business in the cast iron industry to have published a third-party validated Environmental Product Declaration (EPD)

+38: our indicator « Employee Net Promoter » that reflects the number of staff willing to become Ambassadors of the company (on a scale of -100 to +100)

35% female managers

1/3 internships and work-study contracts converted to full employment contracts

As a member of the **Saint-Gobain Group**, a **350-year old** world leader in providing innovative and sustainable construction products

167,000 employees and over **100 nationalities** represented



10,000 production sites worldwide

An industrial presence in **70 countries**

CAST IRON, A MATERIAL WITH AWESOME CHARACTERISTICS



FIRE SAFETY



ACOUSTICS



DURABILITY



CHEMICAL RESISTANCE

PRODUCTS THAT ADAPT TO THE CONSTRUCTION CHALLENGES OF TODAY AND TOMORROW



SOLUTION PRE-ASSEMBLY



ELIXAIR® Earth-to-air heat exchanger

OUR MANAGEMENT SYSTEM FOR QUALITY, ENERGY AND ENVIRONMENT CONTRIBUTES TO THE CONTINUOUS IMPROVEMENT OF OUR ACTIVITY



For **PAM Building**, being committed to sustainable development actions by ensuring its plants' full compliance with current regulations is just the start.

Plants in the metallurgical industry call for greater vigilance and strict compliance with instructions, as the risks of serious accidents are particularly high.

The comprehensive approach adopted led us to obtain first the ISO 14001 and 50001 certifications for our plants but also recently BES 6001 for Telford site.

SAFE AND SUSTAINABLE BY NATURE

COMMITTED TO REDUCING OUR IMPACT ON THE ENVIRONMENT

Our 2025 objectives vs 2010

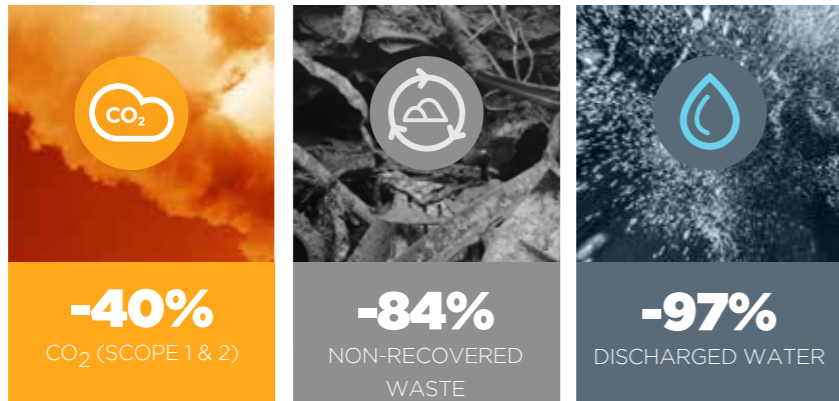

Our commitment to reduce CO₂ emissions by 2030: **-80%** vs 2017

COMMITTED TO THE SAFETY AND DURABILITY OF BUILDINGS



Our cast iron solutions and systems help ensure the comfort, safety and durability of the most demanding residential and commercial buildings.

Their exceptional characteristics allow them to contribute to HQE, BREEAM, LEED and other international environmental certifications...

- > High-rise buildings
- > Hotels
- > Offices
- > Hospitals and Health Centers
- > Cultural buildings
- > Structures dedicated to leisure
- > Railway stations and airports

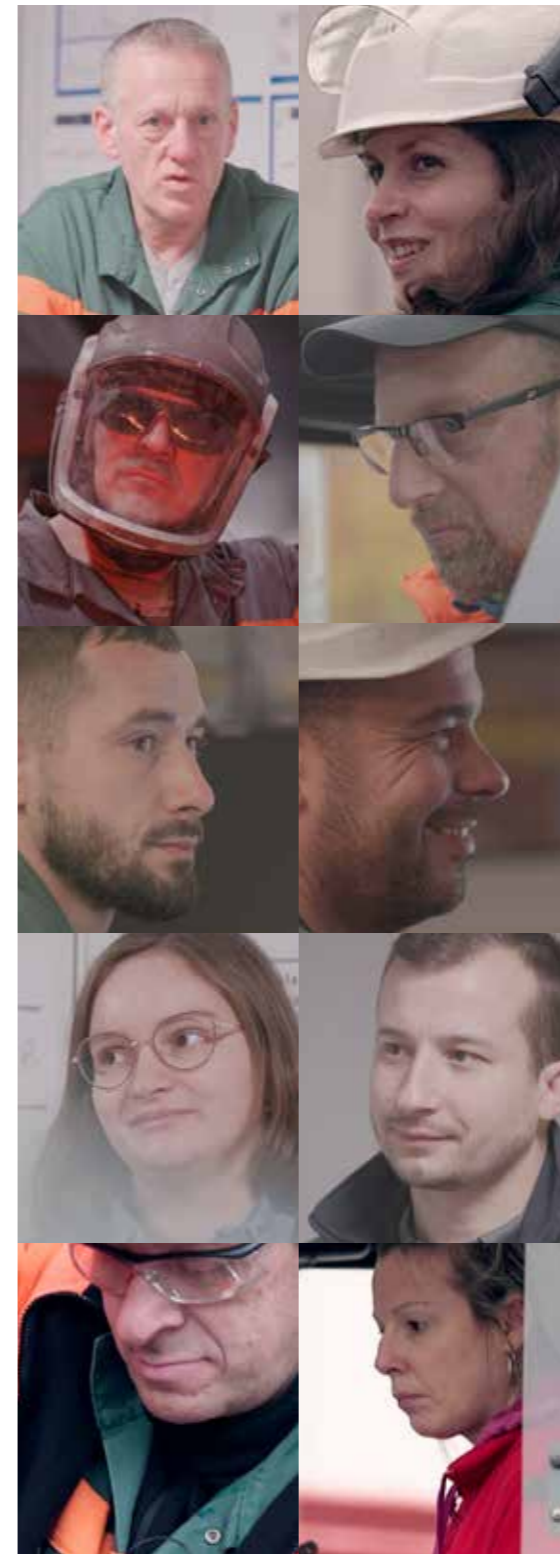

OUR STRENGTH IS IN OUR PEOPLE

Our corporate culture attracts and develops the talents of the people in our teams over time.

We forge the technical competence that pushes us to the forefront of everything we do.

PAM Building believes in youth and proves it by integrating young graduates, its practice of apprenticeship and development.

Our commercial approach transforms us into providers of technical solutions to exceed our customers' expectations.

Our team provides excellent service and technical support during the design, implementation of a project.

Our project managers ensure daily follow-up in the field to guarantee the best possible conditions for implementation.

OUR PRODUCTS, PEOPLE, TEAMS ARE HERE TO HELP YOU MAKE THE WORLD A BETTER HOME.

01

BUILDING SOLUTIONS & REFERENCES

- 10 HOTELS
- 13 HIGH-RISE BUILDINGS
- 14 HEALTHCARE FACILITIES
- 17 CULTURAL & LEISURE FACILITIES
- 18 AIRPORTS
- 19 INFRASTRUCTURES



Hotels are very special buildings since for a short time they act as a second home for the people staying in them. Customers therefore expect hotels to be restful and relaxing places.

The higher the hotel is rated the higher the specifiers' requirements for safety and comfort.

Wastewater and rainwater drainage systems are needed to maintain a peaceful and safe environment, requiring strong and durable materials, with minimal maintenance. Safe, totally watertight and silent in operation, the PAM cast iron drainage solution is the top choice for wastewater drainage systems in hotels.

Combining top-quality products and unrivaled longevity, the PAM cast iron drainage systems help maintain the sustainable and comfortable environment your building projects require.



	FIT	
	S Range	Plus Range
① Sanitary blocks (grey and black water)	★	
② Rainwater stacks	★	
③ Car parks	★	
④ Laundry, bleachery (chemicals + hot temp)		★
⑤ Restaurant kitchens (grease + hot temp)		★
⑥ Swimming pools (aggressive environment)		★



CHEMICAL RESISTANCE



FIRE SAFETY



ACOUSTICS



DURABILITY

HOTELS

HIGH-RISE BUILDINGS

01

BUILDING SOLUTIONS

WORLDWIDE REFERENCES

- Four Seasons Hotel - Moscow - Russia
- Shangri-La Island Hotel - Honk Kong- China
- Rixos Tersane Hotel - Istanbul - Turkey
- Club Med La Rosière - Montvalezan - France
- Hyatt Regency - Algier - Algeria
- Royal Mansour - Casablanca - Morocco

- Peninsula Hotel - London - UK
- Raddisson Hotel - Bursa - Turkey
- AZALAİ 5* - Ouagadougou - Burkina Faso
- City Of Dreams Mediterranean - Limassol - Cyprus
- Movenpick Hotel Diplomatic Quarter - Riyadh - KSA
- Sofitel Singapore City Center - Singapore - Singapore

WORLDWIDE REFERENCES

- Lakhta Tower - Saint-Petersburg - Russia
- Ziraat Bank Financial Center - Istanbul - Turkey
- CFC Tower - Casablanca - Morocco
- Duo Tower Paris - Paris - France
- Seef Lusail Residential Development Plots D3&D4 - Lusail - Qatar
- Central Bank of Azerbaijan - Baku - Azerbaijan

- Studio City Phase 2 - Macau - Macau
- Kula Belgrade - Belgrade - Serbia
- Downtown One - Tirana - Albania
- Air Algeria Tower - Algier - Algeria
- Glory - 88 Market Street - Singapore - Singapore
- Al Wasl Tower - Dubai - UAE



- 1 | Four Seasons Hotel - Moscow - Russia | **S range**
- 2 | Shangri-La Island Hotel - Honk Kong- China | **Zn range**
- 3 | Rixos Tersane Hotel - Istanbul - Turkey | **S range**

- 1 | Lakhta Tower - Saint-Petersburg - Russia | **S range**
- 2 | Ziraat Bank Financial Center - Istanbul - Turkey | **S range**
- 3 | CFC Tower - Casablanca - Morocco | **S range**

Healthcare facilities have specific requirements that must be considered when designing wastewater drainage. Wastewater drainage systems in these buildings will face demanding operating conditions due to the types of effluents they carry, high operating temperatures and intensive use. In buildings dedicated to providing people with care, the pipe systems must meet more stringent requirements to maintain a safe and comfortable environment. To minimize the risk of ward closures or any disruption to medical care, the pipe system selected should require limited repair and maintenance.



CHEMICAL RESISTANCE

Effluents drained in healthcare facilities can be aggressive (especially from laboratories, etc.) and/or reach high temperatures (kitchens, laundry, etc.). These characteristics must be addressed to protect the durability of the wastewater systems and avoid premature and costly repairs, liable to disrupt continuity of service.



FIRE SAFETY

The pipework is the building's arteries, passing through structures - walls and slabs - designed to contain fire. In case of fire, the main risk for wastewater pipe systems, in addition to early collapse, is that they could fuel and potentially spread the fire. Since a fire in healthcare buildings can have even more harmful effects, careful selection of the pipe material is key to protecting both people and property.



ACOUSTICS

In healthcare facilities more than anywhere else, noise is an unacceptable nuisance, disturbing the patients' rest and the staff's attention. Among the noises emitted within buildings, some stem from equipment including pipework flow noises and airborne or structure-borne noise.



SPECIAL TESTS CARRIED OUT ON PLUS INNER LININGS

The pipe sample (upper) and fitting sample (lower) were immersed for 30 days in different solutions widely used in hospitals in Europe for different purposes. The concentration and temperature were those recommended by the manufacturer. These severe tests aim to simulate accelerated ageing.

USE	Operating temperature	pH
Hand soap	40°C	7.88
High-level disinfectant	40°C	5.45
High-level disinfectant	40°C	5.81
Detergent	50°C	9.37
Pre-disinfectant for medical and surgical instruments	30°C	7.3
Pre-disinfectant for medical and surgical instruments	20°C	6.9
Disinfectant for medical and surgical instruments	20°C	4.71
Disinfectant for medical and surgical instruments	55°C	11.8
Rinsing product and lubricant	55°C	6.37
Disinfectant and descaler for hemodialysis	20°C	3.92
Descaler for dishwasher	65°C	1.25
Cleaning product with biological action	60°C	7.52

No damage was observed after the tests either on the PLUS pipe or the PLUS fitting samples.

> APPLICABLE RANGES

RECOMMENDATIONS	S Range	Plus Range
Sterilisation, hemodialysis, OR Laboratories		★
Departments dealing with aggressive fluids and/or high temperatures		★
Wards, offices, treatment rooms	★	
Laundry, bleachery		★
Kitchens		★
Car parks		★
Grey wastewater, black water	★	
Aggressive and/or high-temperature fluids		★
Rainwater	★	
Crawl spaces		★
Grey wastewater, black water	★	
Aggressive and/or high-temperature fluids		★
Rainwater	★	
Heliport		★

Plus Range



S Range



HEALTHCARE FACILITIES

CULTURAL & LEISURE FACILITIES

01

BUILDING SOLUTIONS

WORLDWIDE REFERENCES

City Clinic Hospital - Kommunarka - Russia
 Acibadem Hospital Ata ehir - Istanbul - Turkey
 Sidra Hospital - Doha - Qatar
 Military Hospital - Tamanrasset - Algeria
 CHU ABYME - Guadeloupe - France
 Grange University Hospital - Wales - UK

Princesse Grace Hospital - Monaco
 CHU de Michalon - Grenoble - France
 Bozüyük State Hospital - Bilecik - Turkey
 Clínica Universitaria de Navarra - Madrid - Spain
 Children's Hospital - Helsinki - Finland
 CHU Tangier - Tangier - Morocco

WORLDWIDE REFERENCES

Grand Theatre Rabat - Rabat - Morocco
 Zaryadie Philharmonic Hall - Moscow - Russia
 New Atatürk Cultural Center - Istanbul - Turkey
 Shaw Auditorium - Hong-Kong - China
 Berraki Stadium - Algier - Algeria
 Arribat Mall Center - Rabat - Morocco

Kai Tak Sports Park - Honk Kong - China
 Istanbul Museum of Modern Arts - Istanbul - Turkey
 11 Skies Commercial Complex - Honk Kong - China
 UAE Pavillion EXPO 2020 - Dubai - UAE
 Munch Museum - Oslo - Norway
 Oasis Mall - Doha - Qatar



1 | City Clinic Hospital - Kommunarka - Russia | **S & Plus range**

2 | Acibadem Hospital Ata ehir - Istanbul - Turkey | **S range**

3 | Sidra Hospital - Doha - Qatar | **S range**

1 | Grand Theatre Rabat - Rabat - Morocco | **S range**

2 | Ataturk Cultural Center - Istanbul - Turkey | **S range - EPAMS®**

3 | Zaryadie Philharmonic Hall - Moscow - Russia | **S range**

AIRPORTS

INFRASTRUCTURES

01

BUILDING SOLUTIONS

WORLDWIDE REFERENCES

Domodedovo Airport - Moscow - Russia
 Rize Airport - Rize - Turkey
 Geneva Airport - Geneva - Switzerland
 Hong Kong Airport Terminal 2 Extension - China
 Muscat International Airport - MC 5 - Muscat - Oman
 Athens Airport Extension - Athens - Greece

International Airport Terminal 3 - Frankfurt - Germany
 Changi Airport Terminal 4 - Singapore - Singapore
 Ahmad Yani Airport New Terminal - Semarang - Indonesia
 Ahmed Ben Bellah International Airport - Oran - Algeria
 Manchester Airport Terminal 2 - Manchester - UK

WORLDWIDE REFERENCES

Dumbea Bridge - Noumea - New Caledonia
 TGV Train Station - Kenitra - Morocco
 Gayrettepe - Istanbul Airport Metro - Istanbul - Turkey
 Cross Yarra Rail Tunnel - Melbourne - Australia
 Tournon Viaduct - Savoie - France

Mont Blanc Tunnel - Haute-Savoie - France
 Kula Vodno - Skopje - North Macedonia
 Eurasia Tunnel - Istanbul - Turkey
 Doha Metro - Doha - Qatar
 Step Project - Abu Dhabi - UAE



1 | Domodedovo Airport - Moscow - Russia | **S range**

2 | Rize Airport - Rize - Turkey | **S range**

3 | Geneva Airport - Geneva - Switzerland | **S range - EPAMS®**

1 | Dumbea Bridge - Noumea - New Caledonia | **Itinero®**

2 | TGV Train Station - Kenitra - Morocco | **S range - EPAMS®**

3 | Gayrettepe - Istanbul Airport Metro - Istanbul - Turkey | **S range**

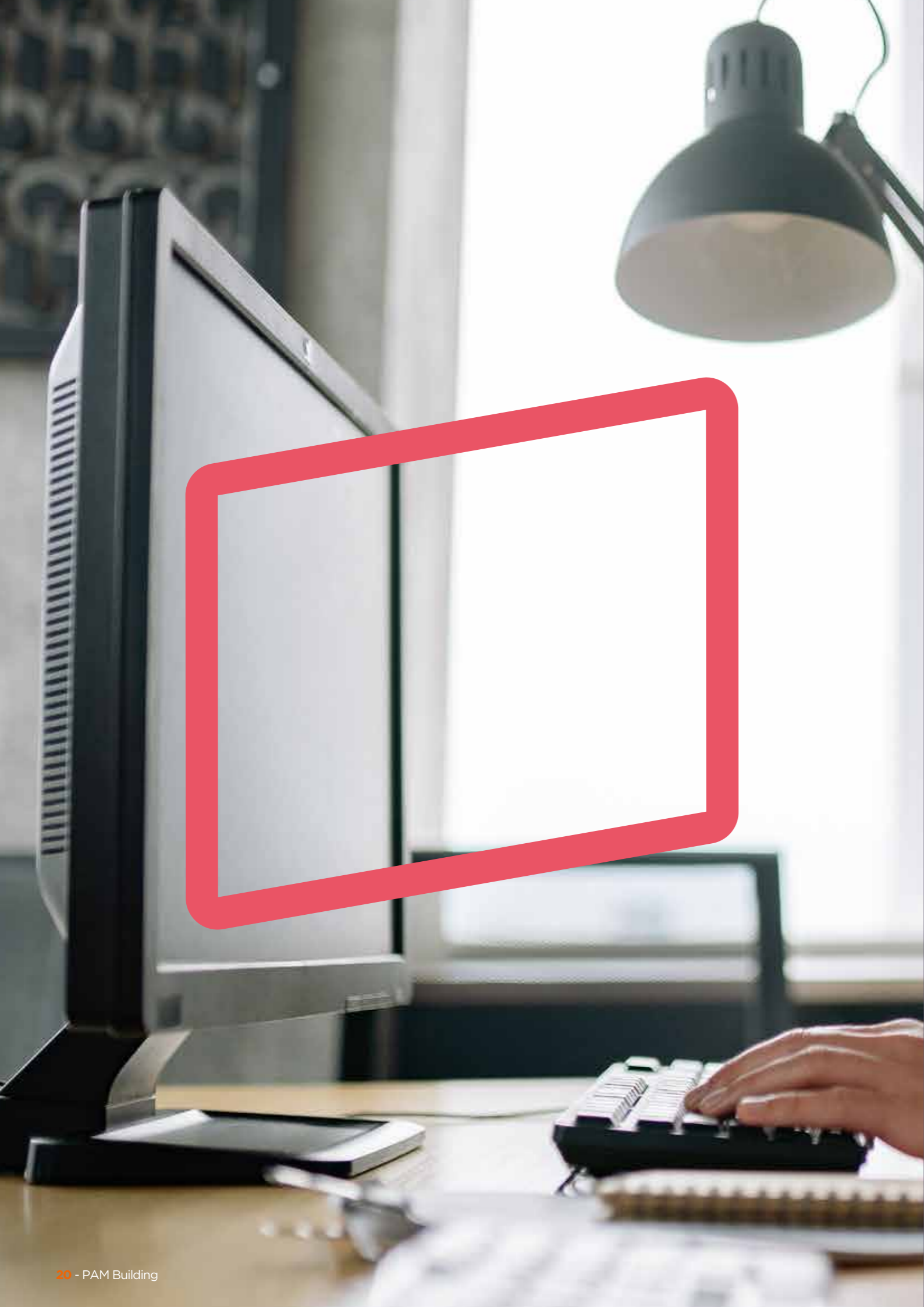

02

OUR SERVICES

- 22 TECHNICAL SUPPORT
- 26 BIM SERVICES
- 28 CUSTOMER SERVICES
- 30 DIGITAL



DESIGN STUDIES

To help our customers define the most optimised network for EPAMS®, ITINERO® or ELIXAIR® systems, our technical support team designs solutions and provides drawings and bills of quantities.



EPAMS®

You have a project to discharge rainwater on a flat roof and you want to quickly define the details and costs of the EPAMS installation (see also p.172).

Send us:

- > Your drawings in DWG format (roof, levels, section views, etc.).
- > The general rainfall intensity of your country (in mm/hr or l/s.m).

You will receive a response within 2 days concerning the feasibility and an initial design study*.

**Full studies are conditional upon the final order of the materials.*

ITINERO®

For our new dedicated range of bridges and tunnels (see p.76), we can support you with the system's complete design.

Send us:

- > The drawing of the bridge
- > The drainage location (outlet and collector) in DWG format.

We will provide you with:

- > A design recommendation
- > The discharge system's set-up
- > A bill of quantities.

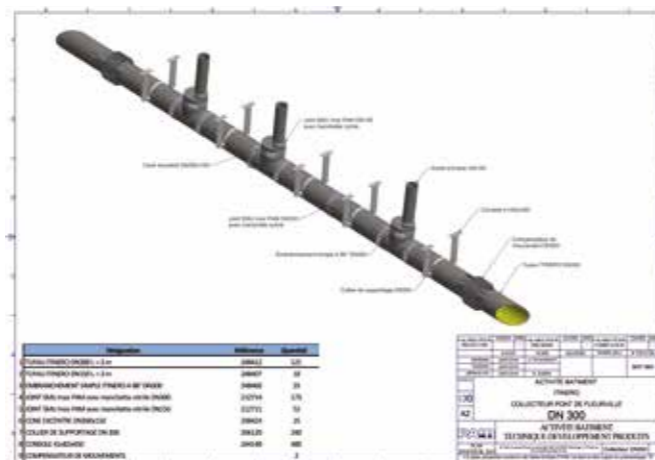

ELIXAIR®

With global warming and the growing importance of energy efficiency, our earth-to-air heat exchanger ELIXAIR system (see p.78) is becoming increasingly specified.

If you are asked to quote ELIXAIR®, send us your project and we will be able to help you with the supply of:

- > Your earth-to-air heat exchanger
- > The bill of quantities
- > The heat energy saved in winter
- > The cooling energy saved in summer.

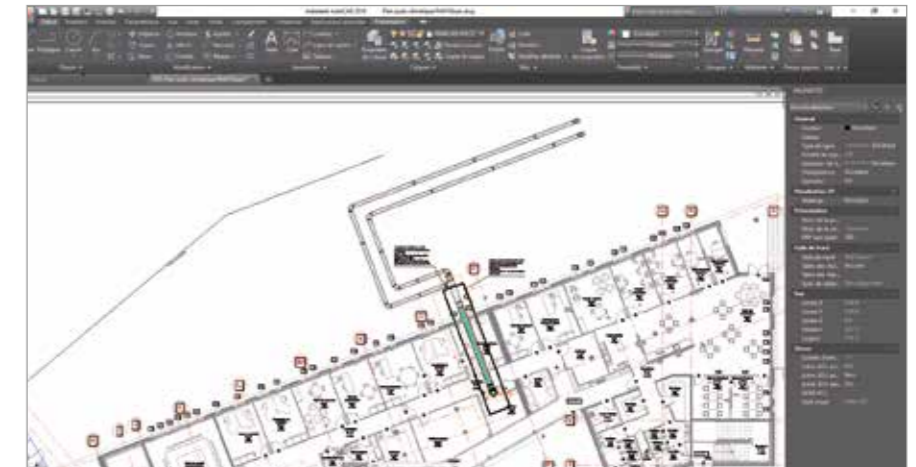

ESTIMATE YOUR PROJECT

You are in a rush or merely have some doubts before finalising your quotation. PAM Building has set up a service for you.

Send us the drawing of the discharge system's location with details of the pipe diameters in the following formats: DWG (preferred), RVT or PDF.

Based on general plumbing rules, we will provide you with the general bill of quantities including:

- > The numbers of the parts
- > The references to order.





TECHNICAL EXPERTISE & INSTALLATION RECOMMENDATIONS

Our service portfolio is fully aligned with the new expectations of MEP consultants and contractors working on safe, comfortable and durable building projects.

In addition to our recommendations in this catalog, if you have any questions, you can ask our experts on the following topics:

- > Acoustics (p.44)
- > Fire protection (p.40)
- > Technical and functional advice (see “Design & Recommendations” section)
- > Environmental building certifications (p.63)

BESPOKE DEVELOPMENT

Upon request, PAM Building can provide special designs of fittings outside the ranges offered in our catalog*. Send us your details and we will provide a response concerning the feasibility within two days.

The latest example is the 125 x 100 x 100 mm Double Branch, which is now available in our product range.



**Sales to order only*

JOB SITE DIAGNOSIS

Drainage pipe systems are often considered utilitarian. As non-visible arteries, they are often poorly maintained and neglected in renovation planning, yet they can ruin the lives of the buildings’ occupants by causing major damage.

PAM Building therefore offers a diagnostic service. The company has decades of experience which has resulted in:

- > Creation of a database of the disruption and failures experienced on pipework systems.
- > Many requests for expertise because cast iron used to be the market’s technical reference.

We can either perform the diagnostic ourselves (chargeable service) or train your teams to perform it, to avoid part renovation which brings further disruptions.

To help us provide professional services, we are equipped with:

- > Hygrometer
- > Temperature sensor
- > Toximeter (measurement of hydrogen sulfide)
- > Inclinator
- > Fluorescein
- > Ultrasonic sensor
- > Feedback.

How does it benefit the owner or maintenance team?

- > Get a global picture of the wastewater and rainwater pipe systems
- > Perform an audit of pipe discharge drainage
- > Map and date the pipework, analyze the interactions and assess the condition.

After diagnosis you will have a list of recommendations, with a view to guiding professional interventions, carried out in compliance with regulations and best practice

For more information, contact us: tcbatiment.sgpam@saint-gobain.com





PAM Building aims to ease the burden on developers, specifiers and contractors in the early stages of construction by providing two levels of BIM library and supporting information.

The new releases include a full-data objects library, a platform that provides supporting information and free individual BIM files for all products and systems.

These include an EN 877 “Generic Cast Iron” content package for use in the early design stages, with parametric model fittings, and standard geometric settings. The files contain only the most vital information, reducing the time and effort required to create early stage plans. These “data-light” designs

can also be overwritten with the full data specification libraries without issue, speeding up later stages of development that require more detailed plans, streamlining the transition from design to as-built work flow.

The PAM BIM Libraries are designed to aid data transmission between the consultants and the Main Contract MEP design engineers, creating a leaner process that reduces design time. As the transmissions usually require more explicit data to be added to the models, PAM Building is also currently creating plugins to quickly add the full data, either automatically by system type, or through floor level and manual area selection.

By providing small file sizes for the generic content, it will facilitate early stage specification in BIM and speed up the whole planning process; this in turn will create measurable cost and time savings for our customers.

Available content

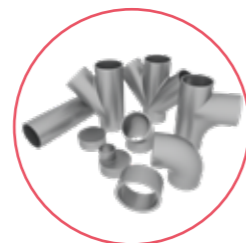

EN 877 CAST IRON GENERIC BIM LIBRARY



S RANGE BIM LIBRARY EN877



PLUS RANGE BIM LIBRARY EN877

PAM Building has been developing BIM Level 2 libraries in Revit for its domestic use (S), siphonic rainwater (EPAMS®) and intensive use (Plus) ranges. Contact our technical support team: tcbatiment.sgpam@saint-gobain.com



NEW REGISTRATION REQUIRED TO KEEP UP TO DATE WITH NEW/REVISED CONTENT



FULL PARAMETRIC PIPE SYSTEMS GENERIC AND FULL DATA



ACCESS TO GUIDANCE VIDEOS AND 'HOW TO?' FAQs

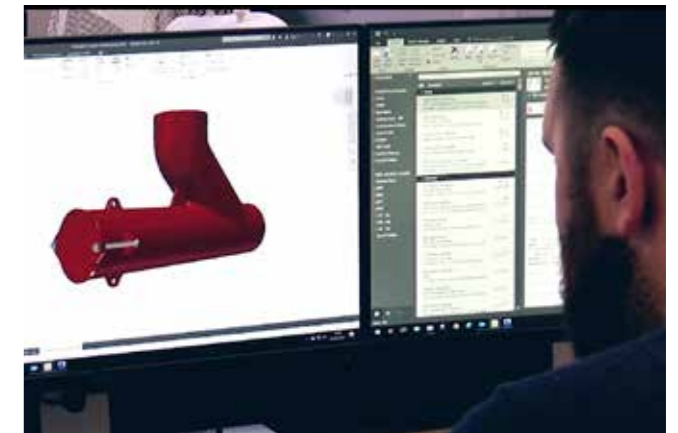

EN 877 CAST IRON GENERIC LIBRARY

- **Generic cast iron content**
 - > Full range of cast iron fittings
 - > All families have 'real geometry'
 - > Generic coupling with 'fixing zone' visibility
 - > All fittings have constrained couplings which can be turned on/off
 - > No 'manufacturer' data
 - > All files are light at 500 KB max

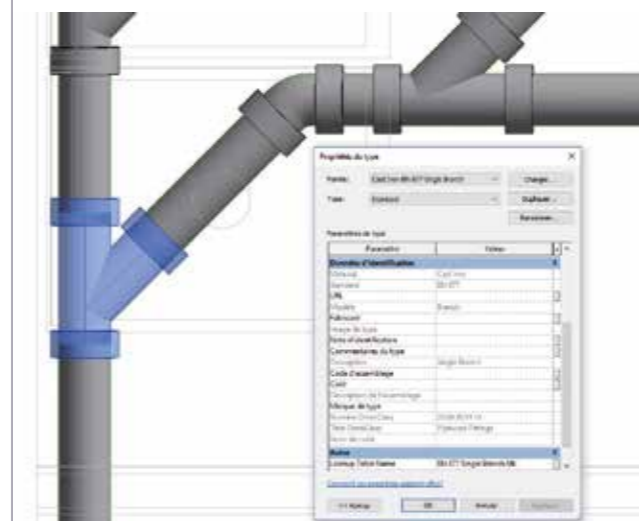

PAM CAST IRON LIBRARY

- **Full data content**
 - > Minor modifications to project design stages
 - > Time saving design for main contract BIM Engineers

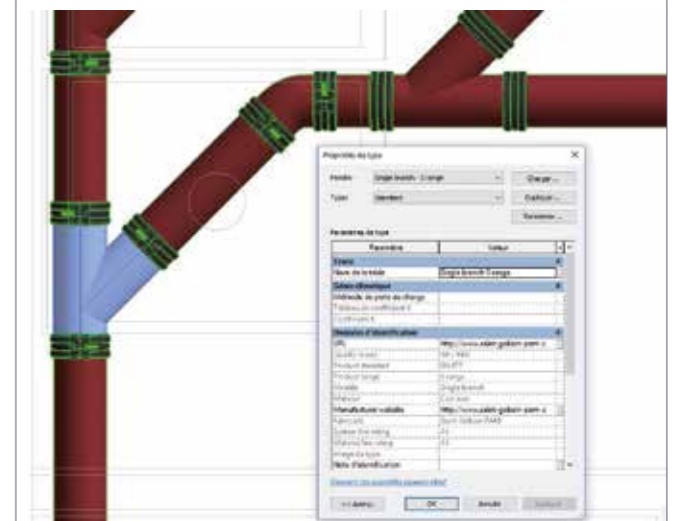

WE SELL PRODUCTS ALL OVER THE WORLD

With 150 years of experience in worldwide export sales, our international organization obtains all our customers' feedback which we need to help us constantly improve our products and services.



OUR CUSTOMER SERVICE TEAMS WILL BE HAPPY TO HELP!

To optimize its customer service, PAM Building has an integrated network of subsidiaries, agents and distributors which can rely on dynamic and experienced technical sales teams to provide excellent customer support.



For enquiries, our customer service is available from Monday to Friday from 8:30 am to 5:30 pm (French time):

Phone : +33 3 83 80 76 50 / 53 / 54

Fax : +33 3 83 80 76 57

You can also find the contact details of our sales area manager on our website.

WE PROVIDE LOGISTICS SERVICES

Every day, PAM Building ships a wide range of products to provide its customers with complete, operational solutions wherever they are. Depending on your needs and practices, you can either manage the transport yourself or we can quote you in accordance with the Incoterms you wish to contract with us. To speed up the process, we have signed an agreement with French Customs.

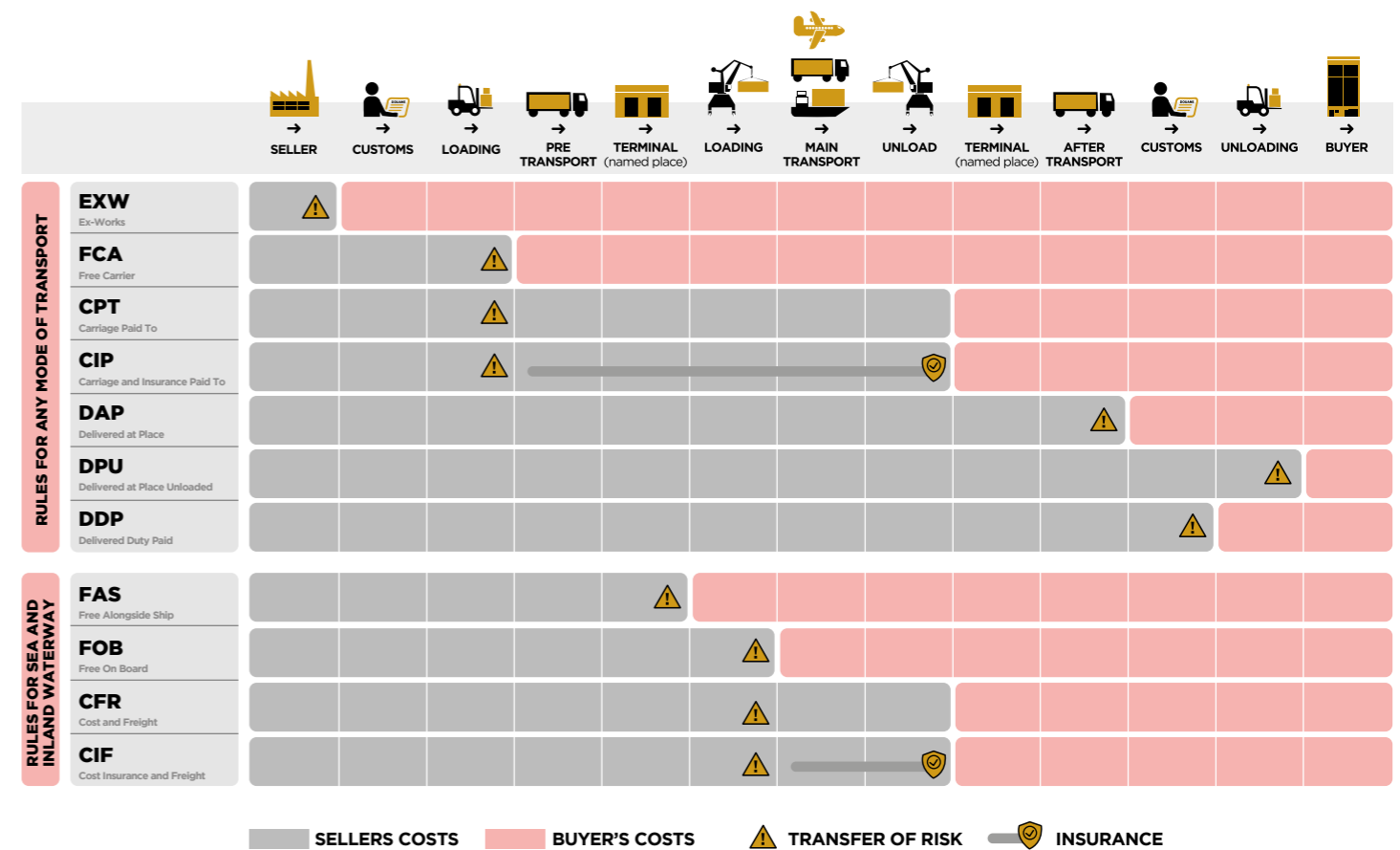

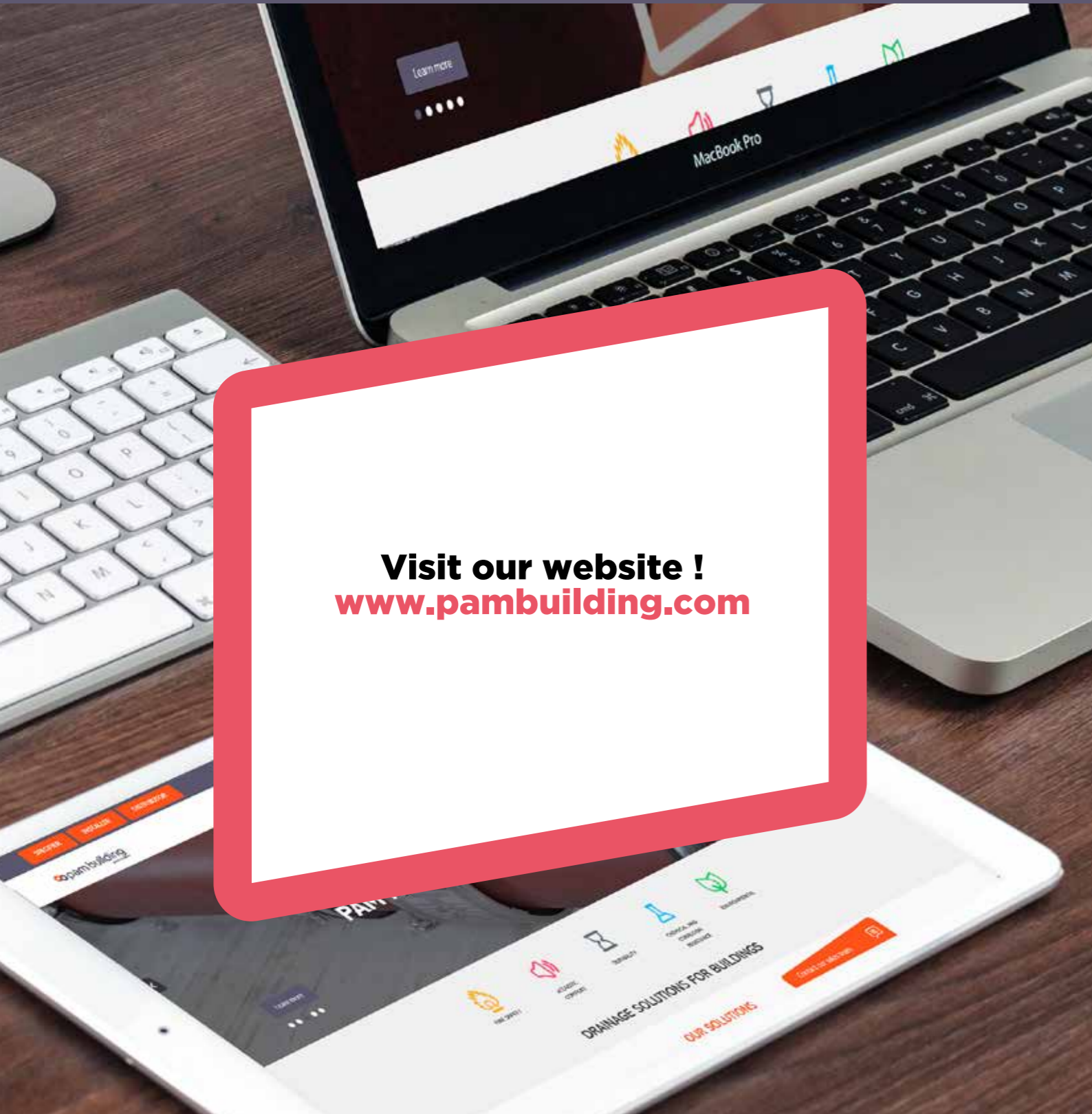

Visit our website !
www.pambuilding.com

Follow the latest news from PAM BUILDING on LinkedIn



Follow us on 

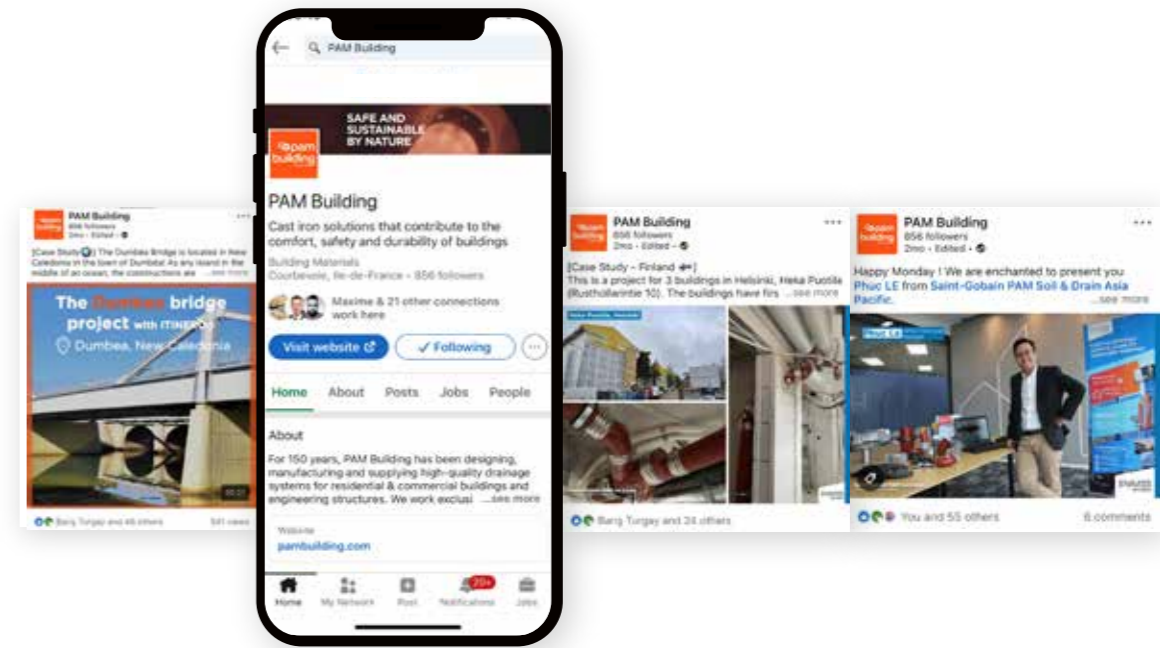

Discover our YouTube Channel !

In our YouTube channel, you find installation tutorials of cast iron pipes, fittings and couplings, as well as informations about products, BIM service, production facilities, news and commitments.

Follow us on



03

WHY USE CAST IRON?

- 36 STANDARDS & CERTIFICATIONS
- 40 FIRE SAFETY
- 44 ACOUSTIC COMFORT
- 48 DURABILITY
- 54 CHEMICAL & CORROSION RESISTANCE
- 60 ENVIRONMENT



WHY USE CAST IRON?

Cast iron systems, an obvious choice

03

WHY USE
CAST IRON



As a leading manufacturer and the world's top-ranking exporter of cast iron pipe systems for building drainage applications, PAM Building is an essential partner for wastewater and rainwater drainage system designers. PAM Building cast iron products are safe, easy to install and effectively meet project managers' requirements. We provide different ranges to suit all building types and specifications.

CAST IRON PIPES GIVE OUR WASTE A SECOND LIFE

Cast iron products for building drainage systems are made of an alloy : iron, carbon and silicon. Cast iron is manufactured entirely from recycled raw materials: scrap iron and cast iron which are enhanced by a second melting process.

PAM Building cast iron combines the traditional longevity of iron with outstanding technical and mechanical properties which remain stable over time in all climates. Its robustness limits breakages and damaged supplies, and its nature and density confer thermal and acoustic properties guaranteeing safety and comfort in use.

MAIN CHARACTERISTICS OF CAST IRON

- > Quick standard installation with mechanical couplings assembled with simple tools, without gluing or welding, which can save time and labor costs.
- > No expansion joints which facilitates the design and saves on expensive thermal limiters.
- > No systematic fire protection or fire collars due to its fire behavior
- > Less protection for acoustic insulation due to its acoustic properties, resulting in plasterboard savings while achieving the same performance.
- > Less embedment than other materials in buried applications where ground disturbance or extra loading is likely.



DURABILITY AND LESS MAINTENANCE

Cast iron has a proven 70-year lifespan due to its outstanding mechanical properties and safety margin in operation.

- > Cast iron systems withstand cleaning operations, even at high pressure. They also withstand traditional unblocking chemicals and enzymes without damage: PAM Building is continuously carrying out research on its coatings to maintain such qualities.
- > Cast iron in exposed sections of the drainage system, i.e. basement car parks, is more resistant to damage than other drainage materials. It is also less sensitive to cracks and breakage prior to installation.
- > Cast iron below ground offers greater resistance to ground movement, and is less likely to fail in unfavorable conditions.

With our networks, maintenance operations are limited.

- > Cast iron drainage requires minimal maintenance during the lifetime of the building under normal conditions, making it the first choice for concealed, built-in or otherwise inaccessible systems, where repair or maintenance would cause major inconvenience to the occupants.
- > Where necessary, removable mechanical couplings make repairs easier and cheaper without cutting into the stack. An extensive range of access parts provides ease of maintenance at vital points in the stack to relieve any blockages which may occur.
- > In the event of destination changes in the premises or the addition of devices, the PAM systems, whose junctions are not glued or welded, can be modified without having to break or cut them, by simply removing the joints.





PRODUCT PERFORMANCES

PAM Building pipe systems comply with European standard EN 877, applicable to a system (cast iron pipes and fittings, couplings and accessories for building drainage). This standard, specifying the technical requirements for cast iron products, is the most stringent in the market.



In particular, it specifies requirements regarding:

- > Reaction to fire (product range)
- > Resistance to internal pressure
- > Dimensional tolerances
- > Tensile strength, crushing strength
- > Joints and their leak tightness
- > Inner lining and external coatings and their suitability

It also defines test methods and the quality management system. Except for reaction to fire properties, EN 877 is a self-declared standard; the manufacturer is allowed to self-declare that their product complies with this standard.

Only compliance with EN 877, which is validated by a third party for all criteria and periodically tested, can guarantee the performance of the systems you specify.

The quality of product ranges is guaranteed by quality marks:
Marque NF, RAL-GEG, Kitemark, BBA, Sintef, Gost, Q+.



	European standards	International standards
Cast iron pipes and fittings, their joints and accessories for the evacuation of water from buildings - (Requirements, test methods and quality assurance)	EN 877	
Elastomer seals - Material requirements	EN 681-1	ISO 4633
Requirements for a quality management system design, product development, production, installation and after-sales support		ISO 9001
Environmental management system - (Requirements with guidance for use)		ISO 14001
Energy management system		ISO 50001
Testing standards		
Fire tests		
Fire classification of construction products and building elements. Classification using data from reaction and resistance to fire tests	EN 13501-1 EN 13501-2	
Reaction to fire tests for building products - Part 1 Building products excluding floorings exposed to thermal attack by a single burning item	EN 13823	
Measurement of noise		
Laboratory measurement of noise from wastewater installations	EN 14366	

CE MARKING: WHY IS IT REQUIRED?

The European Construction Products Regulation made CE marking mandatory on products for which the manufacturer has drawn up a declaration of performance.

The CE marking indicates that manufacturers take responsibility for the construction product's conformity with the declared performance as well as compliance with all applicable requirements laid down in the European Construction Products Regulation.



- > To allow for free circulation of industrial products within the European Union and the European Economic Area
- > To guarantee that these products are not dangerous to European consumers and users
- > To have the same safety criteria shared throughout Europe.

Fire safety was selected as the only essential requirement for the CE marking on wastewater products, which must be supported by laboratory tests conducted at recognized independent facilities. This led to a "Reaction to fire" classification in the Euroclass system.

Our cast iron drainage systems are manufactured to harmonised European standard EN 877 and have therefore required CE marking by law since July 2013. Although it is not a quality standard, the CE mark is a self-declaration of product performance with the exception of reaction to fire, which requires mandatory certification by independent tests at a recognised fire testing center.

A summary of the Declaration of Performance (DoP) for all our ranges is available on our website:
www.pambuilding.com

CE marking is not a quality mark or label It is something very different

The CE mark is NOT a quality mark but a self-declaration of product performance (DoP) in reference to its product standard (with the exception of reaction to fire which requires independent testing at a recognised fire testing center).

The CE marking on a product certifies that it complies with the harmonised part of the reference standards and is a minimum prerequisite for placing the product on the market.

Except for the reaction to fire class, the third-party certification of the performances is not guaranteed by EN 877, but by one of the following marks:

Marque NF, RAL-GEG, Kitemark, BBA, Sintef, Gost, Q+.

SCOPE	HARMONIZED EN 877	
	CE MARKING	THIRD PARTY CERTIFIED
TEST		
Reaction to fire	●	●
Internal pressure strength	●	●
Dimension tolerance	●	●
Mechanical resistance	●	●
Tightness	●	●
Durability (internal coating)	●	●
Durability (external coating)	●	●

- Third-party certification not made compulsory by EN 877
- Third-party certified



To comply with the CE mark, PAM Building cast iron drainage systems bear a quality mark to demonstrate the product's standard:

- > Our system complies with all of the standard's clauses.
- > We are periodically audited by a third party.
- > This gives you the ultimate quality guarantee.

Choosing a complete and consistent range of cast iron products, whose assembly has been performance tested against regulatory requirements, provides you with peace of mind that few other materials can guarantee.

PRODUCT MARKINGS

Pipes



Fittings

The identification marking for PAM Building fittings is a label. Marking also identifies the manufacturing site.



QUALITY MANAGEMENT SYSTEM

The plants which manufacture our products are certified for their compliance with the ISO 9001 standard which specifies requirements for a quality management system. The scope of this standard covers product design and development and the quality control of procurement, training, and administrative follow-up.



Bayard plant (Haute-Marne): ISO 9001 and ISO 14001 certified by Bureau Veritas.





Drainage systems are the arteries of a building. In case of fire, there is a risk that pipes will maintain and spread the fire in the building. Pipe penetrations through a separating element like a wall or a slab are always a source of risk for the spread of fire to the adjacent room, the floor below or the floor above. As regards a building's fire safety, the major responsibility rests with the project manager who must comply with local regulations. Accordingly, and particularly in high-risk buildings like high-rise buildings, materials with reduced flammability should be selected as a precautionary measure.

PAM Building is committed to the development of high-quality and high-safety products. Fire safety is one of the main technical performances of our products. In choosing PAM Building cast iron systems, you are guaranteeing the safety of both people and property.

There are two concepts applied to fire safety: **reaction to fire** and **fire resistance**.

REACTION TO FIRE

This is the instant behavior when a fire breaks out, its propensity to ignite or fuel a fire. This behavior is assessed on the basis of standardised tests and described in a Euroclass classification.

The Euroclasses are based on test methods and establish reaction to fire classifications that are harmonised throughout Europe. This means they can be used to compare materials and product performances.

The Euroclass classification ranges from A1 to F, with A1 and A2 being reserved for products that are not, or are only slightly, combustible. The indices s and d respectively refer to smoke emission and the production of flaming droplets.

EUROCLASSES		
A1	-	-
A2	s1	d0
A2	s1	d1
	s2	
	s3	
B	s1	d0
	s2	d1
	s3	
C	s1	d0
	s2	d1
	s3	
D	s1	d0
	s2	d1
	s3	
Classes other than E-d2 and F		

SMOKE production sub-classification
 s1: Low smoke production
 s2: Medium smoke production
 s3: High smoke production

FLAMING DROPLETS sub-classification
 d0: No flaming droplets
 d1: Flaming droplets that persist for less than 10 s
 d2: Flaming droplets

Cast iron remains one of the best materials when it comes to fire safety.

PAM Building cast iron systems are among the safest materials on the market in terms of reaction to fire, and all its drainage systems have been tested independently to the stipulated test criteria.

In tests carried out by the CSTB accredited laboratory, the PAM Building cast iron ranges (pipes, fittings and accessories, including elastomer gaskets and coatings) received the following excellent Euroclass ranking: **A1** for our standard "S" range and **A2-s1, d0** for the "Plus" range.

Scope

The CE marking for cast iron wastewater systems is based on the harmonised standard EN 877, which applies to a system including pipes, fittings, couplings and accessories, and is used to test all of the ranges' components.

The classification obtained by PAM Building covers complete ranges: pipes, fittings, couplings and accessories that are components of a wastewater pipe system.

Check the reaction to fire classification of the products you specify, and ensure the tests were carried out by an accredited testing centre. This compliance is validated by complete quality marks, is periodically tested by accredited third-party laboratories and provides you with a performance guarantee for the systems you specify.



ADVANTAGES OF OUR SOLUTIONS

- ▶ **A1 Euroclass Rating for the S Range - It is completely non-combustible!**
- ▶ **No smoke and no flaming droplets in the event of a fire.**





FIRE RESISTANCE

This is a construction component's ability to withstand fire for a given period of time and to retain its serviceability in the event of fire, avoiding the spread of fire. If a fire breaks out, it is essential to prevent any early collapse of the structure, and then limit the extent of the damage to ensure that occupants can be evacuated and/or belongings will be protected. Many buildings are not sufficiently protected against fire hazards. This means that fire can spread quickly, destroy the building in a short time and, more importantly, endanger the lives of the occupants. When a fire breaks out, the first objective is to slow down its spread both horizontally and vertically.

The main causes of fire are:

- > Faults in electrical systems
- > Human error
- > Overheating
- > Arson

Lightning strikes or explosions play a minor role in the statistics here, but can lead to a chain reaction of fires if they do occur (Source: www.ifs-ev.org).

The fire resistance performance level will be influenced by a number of factors: the pipe diameter, the thickness of the floor or wall, the size of the penetration void, the material used to seal the void and even the stack configuration through the penetration.

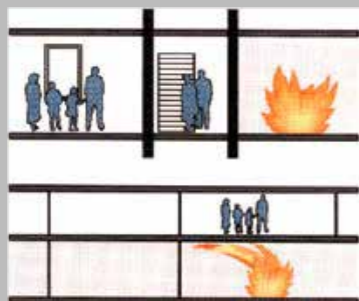

COMPARTMENTAL PRINCIPLE

When they exist, fire safety regulations for buildings are based on a compartmental principle. Within a building, a compartment is a fire rated space designed to stop the fire for a given period of time. The fire stopping requirement for walls (shells and slabs) is generally 2 hours or less - and exceptionally 4 hours.

The requirement depends on the type of building and its level of occupancy, and can be very different from one country to the next.

Wastewater drainage systems and fire stopping requirements

Drainage systems passing through structures designed to withstand fire should not provide open breaches. For a given time, specified in the applicable regulations, they should not allow the passage of fire, smoke, heat or combustion products from one compartment another.

Cast iron, a non-combustible material, has a melting point of over 1000°C. In most cases it requires no additional fire protection.

PAM Building has and will continue to periodically test its cast iron drainage systems with standard mortar penetrations and other solutions in order to understand the potential effects of fire on its integrity, resistance and overall performance. We carried out a non-exhaustive series of tests to offer precise guidance for fire resistance.

Our systems proved to meet integrity and insulation requirements **up to 240 minutes (4 hours)*, and should therefore not collapse causing potential danger to evacuating people or firefighters.**

We regularly perform new tests. Therefore, if you have any questions our technical team can provide guidance and help you select the right configuration for optimal performance and provide you with a comprehensive report. You can contact our technical support team on our website: www.pambuilding.com.

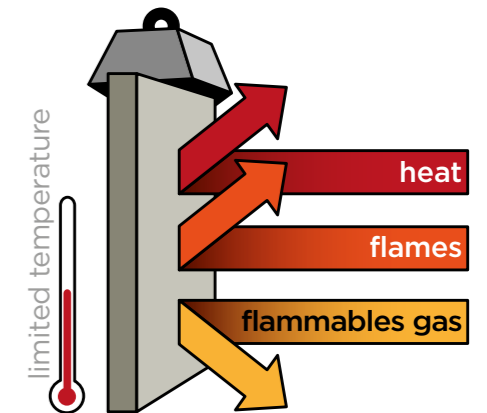

COMPARISON WITH OTHER MATERIALS

For plastics, the fire stopping rule consists in "plugging the hole". This function is achieved by using fire collars recommended by the manufacturers. Plastic materials, which are highly sensitive to heat, will not withstand fire, and will not remain in place, even in the case of a contained fire.

As shown by laboratory tests in Germany, if the fire collars are not activated, particularly when installed under the fire compartment, they significantly increase the risk of the fire spreading downwards in a multi-storey building. When some types of plastic material (e.g. HDPE and Polypropylene) are exposed to fire they generate molten droplets, which could potentially spread a fire down through the building.

Exposed to fire, plastic material releases toxic fumes and gases, which beyond a certain amount may be fatal to the people inhaling them.

Choosing PAM Cast Iron Systems guarantees the safety of both people and property.

* Furnace tests carried out in 2017-2018 according to EN 1366-3 at the EFECTIS testing centre, the European leader in fire science, engineering, tests, inspection and certification.



Noise in buildings is considered to be detrimental to health and quality of life. Efforts have been made in the last 30 years to attenuate the sounds coming from the street, worsening the perception of sounds emitted within buildings. Heat insulation policies aimed at reducing energy consumption will also heighten these perceptions. Among the priority criteria in the comparative performances of drainage materials, acoustic performance is considered to be second only to fire safety: cast iron pipe systems have intrinsic acoustic properties. Owing to the development of equipment accessories, they offer outstanding performances.

WHAT IS NOISE?

NOISE FROM PIPE SYSTEMS

Noise from wastewater pipe systems is classified in the regulation under “equipment noise”. Noise originating from pipe systems is due to the sound energy produced by water/air turbulence, but mostly by the mechanical effect of the water flow on the internal pipe walls. In such circumstances a pipe will radiate noise outward and transfer it to any lightweight ceilings, cupboards and similar areas wherever it makes contact.

Noise is an energy that affects air pressure and is transmitted through vibration.

Sound is measured in decibels (dB) using a nonlinear scale. For equipment noise, the following categories are identified and measured:

Airborne noise:

Air vibrations that are propagated. In the case of wastewater pipe systems, this noise is mainly heard in the room where the pipe is located. When a material is dense and thick, the pipe walls prevent air transmission, as is the case with cast iron which has intrinsic acoustic properties.

Structure-borne noise:

The vibration of a building’s structure. This noise will be noticed in rooms adjacent to the pipe. When the noise produced in a pipe is not transmitted by the air, the residual noise is transmitted by structural vibrations. Whilst the mass of the cast iron limits the vibratory level, the junctions and fixings to the building will propagate noise. Objective: dampen the vibrations at the connections to the solid structure.

Statutory requirements for “equipment noise” for structure-borne noise differentiate between noisy rooms and quiet rooms with sound attenuation requirements. For noisy rooms, the noise level requirements are generally 35 dB or more. For quiet rooms, which are generally living rooms, resting rooms and work rooms, the noise level requirements are generally around 30 dB, in cases where noise regulations exist.



COMPARATIVE LABORATORY TESTS

Acoustic comfort is a differentiation criterion that indicates construction quality. The building project manager and specifier may define together specific requirements to improve the final construction.

In 2019, PAM Building commissioned a series of comparative tests on airborne and structure-borne noises in installation conditions described by standard EN 14366*, at the Fraunhofer Institute for Building Physics in Stuttgart.

The measurement results for the PAM Building cast iron pipes listed in the table were determined at the Fraunhofer Institute for Building Physics on an installation wall with a basis weight of 220 kg/m².

The prerequisite for this was that the building conditions in the real construction situation be comparable to or more favorable than the test bench of the Fraunhofer Institute for Building Physics in terms of sound technology.

When compared with the requirements, pay attention to the simultaneous operation of plumbing installations and possible interactions among the plumbing components which may produce different results. As a comparison value with the requirements, the measured value should be obtained at a flow rate of 2.0 l/s, because this corresponds to approximately one toilet flush. The sound measurements were taken both on the opposite side of the installation (in the picture on the right) and in the mounting room (on the left of the picture).

Details of the test configuration:

- > **Standard bracketing:** 2 bracket collars per floor. Both mounted with a 1 Nm torque.
- > **Stack support:** Stack supports are fixed to the wall/floor.
- > **PAM’Acoustic:** 2 anti-vibration brackets per floor. Both mounted with a 1 Nm torque.

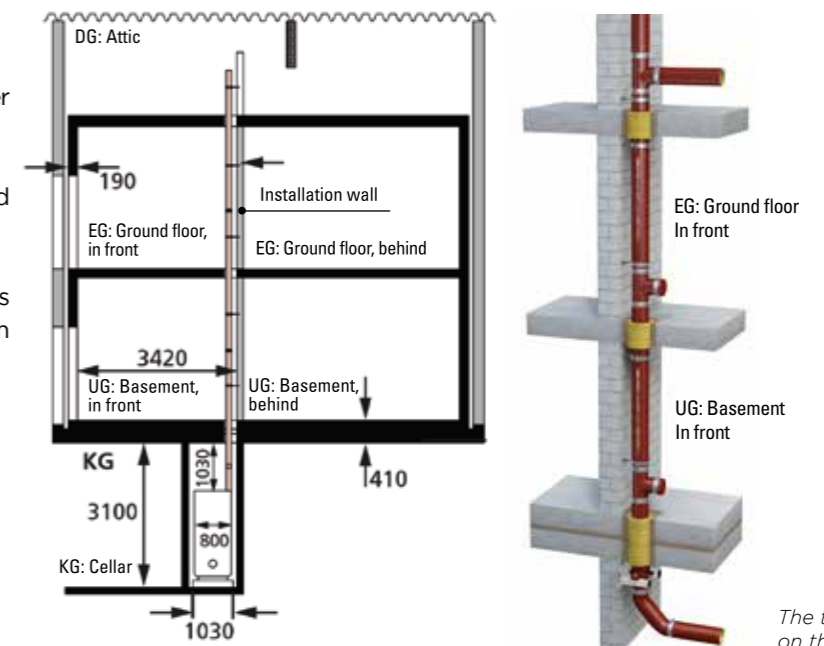

**As all wastewater pipe systems manufacturers apply the standard test protocol, it allows building project managers to compare their results.*

The test results are on the next page



Tests results for the installations, according to EN 14366

Pipe system	Test report N°	Installation acc. to EN 14366			
		Airborne noise ($L_{a,A}$)		Structural noise ($L_{SC,A}$)	
		2.0 (l/s)	4.0 (l/s)	2.0 (l/s)	4.0 (l/s)
S range + classical bracketing with rubber and stack support in basement floor	P-BA 223/2019	47 dB (A)	50 dB (A)	21 dB (A)	26 dB (A)
S range + PAM'Acoustic without stack support in cellar.	P-BA 226/2019	47 dB (A)	50 dB (A)	< 10 dB (A)	< 10 dB (A)

Complete reports are available on request. Sound levels below 10 dB(A) are not mentioned in the test report.

NOISE IN REAL CONDITION OF USE

Usually pipe systems are installed in a technical shaft that contributes to reducing the noise emitted by the effluent flowing in a pipe. Nevertheless, the noise level of pipes installed behind a shaft may not be sufficient to comply with the specifications of the owner or set by the national regulation.

In 2018, PAM Building initiated several noise measurement tests with an independent laboratory in real conditions, inspired by standard EN 14366, but using a real WC flush to assess the noise level of the combination of pipe material and shaft acoustic performance (ΔL_{an}).

Below are some examples of measurements at a flow rate of 2 l/s with the S range fixed on a 15 cm thick supporting concrete wall:

Technical Shaft	S range with rubber lined steel brackets	S range with steel brackets and acoustic dampener
ΔL_{an} Performance	$L_{A,S,max}$ [50-5000 Hz] (dB)	$L_{A,S,max}$ [50-5000 Hz] (dB)
$19 \leq \Delta L_{an} < 24$	33	32
$24 \leq \Delta L_{an} < 29$	30	25
$29 \leq \Delta L_{an} < 34$	29	19

Choosing our systems guarantees the best acoustic solution on the market.

Depending on your project specification or national regulation, PAM Building can help you validate your pipework's compliance. Please contact our technical support team on our website: www.pambuilding.com.



Structure borne noise & Pam'Acoustic

For the requirements of extreme acoustic comfort (luxury buildings, auditoriums ...), Pam'Acoustic is an acoustic dampener, which, placed between the frame and the support collar of the cast iron pipe, makes it possible to achieve the exceptional structural noise level of < 10 dB (A), that is, almost silence.

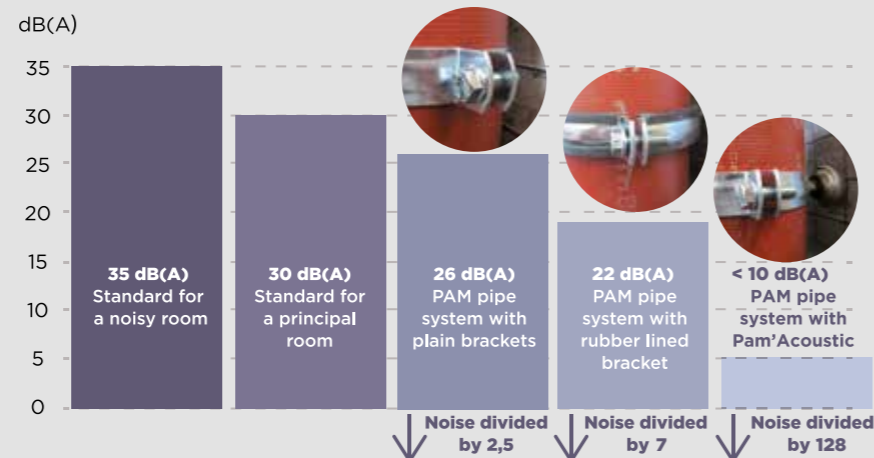

Tests according to standard NF EN 14366 (IBP laboratory). For a flow rate of 2 liters/second, wall: 220 kg/m².

Summary of our solutions:

- > High basis weight
- > Low tendency to vibrate
- > Effective sound decoupling
- > High insulation value
- > Suitable for all pressures
- > Sewage installations
- > Precise installation instructions
- > Compliance with project specifications or regulations



ROBUSTNESS AND MECHANICAL STRENGTH

Pipe system components must withstand hazards before they reach the job site such as accidental impact before and during installation, during storage, handling and transit. In service, outdoor exposed pipes may be damaged by accidental impacts or vandalism. To avoid breakages, which can be expensive, or minor stress cracks which can have serious consequences in operation, the choice of material should be carefully considered.

DE LAVAUD PROCESS

In this process, a constant flow of molten metal at a perfectly controlled temperature and composition is gradually put into a steel mould rotating at high speed. The mould external wall is cooled by circulating water and the evenly distributed molten metal cools on contact with the wall before extraction.

The process is characterized by quick cooling which gives a finer solidification matrix and thus a more homogeneous metallurgical structure.

The spun pipes are placed and rotated in a heat treatment furnace at 950°C and then gradually cooled again. This step is essential to the process as it transforms the cast iron's metallurgical structure. The reduction in iron carbides and the increase in ferrite content considerably improve the mechanical properties of cast iron and reduce its surface hardness. The graphite of the cast iron resulting from the PAM Building process forms clustered graphite, halfway between lamellar and ductile iron.

Impact strength and crush resistance

Compared with other materials, cast iron provides much better impact resistance and is highly recommended everywhere pipes may be exposed to mechanical shock (car parks, streets, etc.).

Cast iron is well known for its robustness. The quality of PAM Building products is ensured by careful control of both the metal composition and the manufacturing process.

The spinning of pipes in the De Lavaud process, followed by heat treatment, gives these products outstanding mechanical properties.

The advantages of the De Lavaud process: better mechanical characteristics, superior to the requirements of EN 877*

- > Very good resistance to crushing.
- > Increased impact resistance.
- > The pipe is more resistant to mechanical stress such as bending and compression.
- > For installers, installation is more comfortable and on-site handling is facilitated. Cutting pipes is easier, the slices are sharp. The set-up is therefore simpler and faster.

The Pipes	PAM Building process	Others	EN 877 requirements
Tensile Strength on samples in MPa (average value)	300	270	200 minimum
Ring Crush Strength in MPa (average value, DN 100 pipes)	450	360	350 minimum
Brinnell Surface Hardness in HB degree (average value)	220	245	260 maximum

These results indicate greater resistance to impacts and crushing, easier machining and cutting. This also means the products are easier to install on job sites.

**Key mechanical characteristics required by standard EN 877 are checked by three tests, carried out on pipes when coming out of the heat treatment furnace to assess tensile strength, ring crush resistance and hardness. In addition, operators have opted to perform a further test which provides a good indication of the heat treatment quality: impact test.*

RESISTANCE TO THERMAL EXPANSION

Most solids expand when heated and are liable to elongate under temperature increases. For pipe systems made of materials that are subjected to high levels of thermal expansion, precautions must be taken at the design stage.

Cast iron, which expands very little, does not require specific bracketing or expansion collars. It makes the specifiers' design work easier and avoids extra costs at the installation stage.

Thermal expansion coefficient of cast iron and other materials

The thermal expansion coefficient for cast iron – 0.01 mm/m. °C – is very low and very similar to that of steel and concrete; the building and pipe systems will move and expand together.

Thermal expansion of cast iron and other materials for a temperature rise of 50°C and 10 m			
Thermal expansion coefficient			
0.0104 mm/m°C → 5.2 mm	Cast iron		
0.07 mm/m°C → 35 mm	PVC		7 times more
0.150 mm/m°C → 75 mm	PP		14 times more
0.17 mm/m°C → 100 mm	HDPE		19 times more

For cast iron, the bracketing system is designed to only carry the weight of the pipe and its content, which makes the designers' work easier. Plastic pipes, however, expand considerably with increasing temperature. Their bracketing system must be designed and adapted accordingly, as it can significantly affect the pipework's stability and performance over time.

Thermal expansion of plastics

To allow expansion without damaging the drainage network, plastic pipe systems require specific accessories – expansion collars or joints, brackets allowing axial movement, in general one of the two. If these precautions were not taken, expansion could be absorbed by the pipework and cause distortion.

Cast iron does not require these expensive accessories. It makes the design work easier and decreases the risk of mistakes at the installation stage.

These properties of cast iron pipe systems are also valuable for engineering structures such as bridges, where significant expansions have to be carefully addressed to secure the construction project.



WATERTIGHTNESS

Sanitary drainage systems, whether exposed or not, must remain watertight over time. Any defects can cause serious damage, leaks, dripping or slow permeation and generate costly repairs, and disruption. PAM Building cast iron mechanical assemblies are designed to easily achieve instant watertightness and are not dependent on process control (gluing or welding, etc.).

Watertightness of cast iron systems

Cast iron is a dense and non-porous material. Cast iron pipe systems are watertight and impervious.

Straight and rigid cast iron components are assembled using metal couplings fitted with elastomer gaskets which ensure the system is completely watertight.

Assemblies benefit from a conventional approach. Put together with only simple tools, they allow installation tolerance with no risk of leaks.

This ease of installation ensures the specified performance is always obtained, even in adverse conditions, unlike with plastics when either gluing or welding can be affected by installation hazards (ambient conditions such as temperature or damp), or when personnel with special skills are required.

Watertightness over time

Failure of watertightness can occur on drainage systems in operation due to breaks, misalignments, crushes or cracks. Long-lasting watertightness depends on two main factors:

- > **No deterioration of pipes:** Cast iron is highly resistant to ovality. Their specified mechanical properties and stability enable cast iron systems to withstand operating stresses extremely well.
- > **No deterioration of assemblies:** Elastomers are carefully selected for the long-term stability of their physico-chemical characteristics to ensure the lasting watertightness of the rubber gaskets.

Watertightness and maintenance

Blockages can sometimes occur in drainage networks, therefore the pipework materials must be resistant so that maintenance is easy. The S and Plus systems can withstand



The S and Plus ranges, assembled and anchored, have successfully passed a high-pressure jetting test: cleaning pressure of 120 bar from the pump, which means 100 bar at the nozzle outlet, without leaks or misalignment.

all normal maintenance processes, including high-pressure jetting, without being damaged. They have undergone a high-pressure test according to Swiss standard SN 592 012.

The robustness and dimensional stability of cast iron components along with the careful selection of elastomer ensure pipe installations are high-performance and have a long service life.

INTERNAL PRESSURE RESISTANCE

Internal overpressure in drainage networks rarely occurs and is always accidental. Thrust efforts in the overloaded sections have to be addressed to guarantee both watertightness and mechanical stability.

As the robust cast iron components can withstand any pressure hazard, the couplings will be subjected to the strain. The quality of the couplings and their careful selection according to their field of use will prevent misalignment or disconnection of the pipework.

Resistance of the couplings to hydrostatic pressure

Standard pressure mechanical couplings:

Wastewater drainage systems – which differ from rainwater drainage systems as regards pressure – are connected to sanitary appliances installed on each storey which may serve as outlets in case of accidental overloading (due to blockages, for example). The pressures that occur cannot therefore exceed the pressure corresponding to the height of one storey, i.e. about 0.3 bar. The couplings we describe as “standard” are perfectly suitable for this common type of application.



High-pressure mechanical couplings:

In some rare cases, a wastewater drainage system may pass through a number of stories without any outlet, and there could be a risk of overloading (blockage due to operation or saturation of the main sewer). The pressure resistance required to ensure these systems remain leaktight and stable in such cases depends on the height of the water column liable to occur, and calls for high-pressure couplings able to withstand the resulting pressure (up to 10 bar).



SPECIFIC POINTS OF THE PIPEWORK: RESISTANCE TO END THRUST EFFORTS

Some specific points on a pipe system may be subjected to thrust loads due to changes of direction and gradient, branches and plugs. To avoid any risk of disconnection or slippage of the pipe components, these loads must be addressed and the sections at risk must be anchored:

- > A section of pipe may be held between two fixed points with ductile iron brackets, for example
- > Alternatively, a self-anchoring coupling or an ordinary coupling anchored with a grip collar can be used

If you need help determining the choices for your project, please contact our technical support team on our website: www.pambuilding.com



AGEING BEHAVIOR

As components that are integrated in buildings, wastewater and rainwater drainage systems must remain in a serviceable condition over the long term despite adverse operating conditions.

Ageing refers to any gradual, irreversible change in a material's structure and/or composition, liable to affect its behavior or serviceability.

When a material is selected, the stability of its properties ensures operational reliability over time.



Stability of cast iron mechanical properties

The ageing of a material may be due to its own instability, environmental or chemical stresses, mechanical strains, or a combination of any of those causes.

It is an established fact that cast iron offers long service, owing in particular to the stability of its mechanical properties over time.

Cast iron is not sensitive to thermal ageing

- > Its mechanical strength remains stable.
- > Its thermal expansion is very low compared to plastics.
- > Cast iron pipe systems are not liable to creep at operating temperatures.

Cast iron does not deform under mechanical strain.

- > Its ring stiffness (cold measurement) around 700 kN/m is not affected by temperature and is 87 times that of PVC pipes. It is highly valued for buried pipework.
- > Its longitudinal stiffness, which facilitates bracketing and protects the water stream in horizontal sections, remains intact. Its Young's modulus of elasticity is from 80 to 120 GPa vs 2 to 5 GPa for PVC.
- > Cast iron's tensile strength is 8 times that of PVC: 200 MPa vs 25 (residual resistance, after 50 years according to the standards). This property is very important in case of network overloading.

The properties of cast iron ensure the stability of the systems and long-lasting operational safety.

Resistance to climatic stresses

The properties of materials are extremely important when they are stored in or exposed to adverse conditions (extended exposure to ultraviolet light or wide-ranging temperature variations, etc.). Cast iron undergoes no structural modification under climatic stresses.

AGEING OF POLYMERS

Deterioration of mechanical properties under temperature stress

Under the effect of temperature, plastics can suffer two kinds of deterioration, including at operating temperatures:

- > **Creeping** is an irreversible elongation under the combined action of both temperature and a significant mechanical strain. Plastic pipe systems like PVC or HDPE are particularly sensitive; in the horizontal sections, they can bend between two support brackets under their own weight.
- > **Modification of the elastic limit:** most plastic materials will soften when exposed to a temperature increase. With a decrease in temperature, however, they crystallise. PVC, for example, becomes rigid and may crack under mechanical strain - its operating temperature range is generally between -20°C and 80°C, but depending on its nature, the range can be much narrower.

Photochemical ageing

Depending on their nature, climatic stresses (such as solar radiation, damp or heat) will cause photochemical ageing to plastic materials of varying severity.

They may merely alter their surface finish, or they may also deeply modify their mechanical properties and thus adversely affect their serviceability.

The same can happen as a result of a slow chemical attack by solvents or even in an aqueous medium.



DOMESTIC USE

Characterisation of common domestic applications

Building wastewater drainage systems - grey and black water- must be able to withstand the types of domestic effluents specified by standard EN 877. In recent years, however, changes have been observed in the types of these fluids:

- Higher concentration of household detergents,
- Use of more aggressive hygiene products,
- Rise in operating temperatures.

The constraints on sanitary drainage systems are constantly increasing.

To test chemical resistance of cast iron products, according to standard EN 877, the product samples are tested for 30 days at a temperature of $23 \pm 3^\circ\text{C}$ with the following liquids (pH constantly monitored):

- > A solution of sulfuric acid with a pH of 2
- > A solution of sodium hydroxide with a pH of 12
- > A solution of wastewater with a pH of 7

Resistance to hot water (24 h at a continuous 95°C) and thermal cycles (1,500 cycles of 5 min between 15°C and 93°C) are also tested according to standard EN 877.

To provide clearer guidance on the chemical resistance of the S range in domestic applications, **PAM Building has carried out 20 further tests in addition to the requirements of standard EN 877** on commonly-used detergent products (floor cleaning products, laundry detergents, etc.) and special products (stain removers, drain cleaners, etc.). The additional tests also aimed to assess the S and Plus range limitations.

The tests were carried out on samples, under the temperature of use recommended by the manufacturers and, where relevant, up to 70°C since hot water is normally supplied in houses at around $50\text{--}60^\circ\text{C}$.

After stopping the test, the pipes and fittings were washed immediately to eliminate any stains, and the coatings were examined for blistering and rusting according to ISO 4628-2 and 3. (Accepted levels according to EN 877).

The duration of the test is considered equivalent to the extrapolation of real chemical stress undergone for 7 or 10 years (10 to 15 min of stress per day). This test method, however, simulates severe stress since the samples lie in direct contact with the solution, the temperature is maintained and the test includes no rinsing for its duration.

		Dilution*	pH	23°	50°	65°	70°	Test duration
SALT WATER	Same as sea water	30 g/l						28 days
DETERGENTS								
Laundry detergents	Phosphate-free detergent	2 ml/l	7.7					28 days
	Softener	2 ml/l	7.6					28 days
Dish washer detergents	Washing tablet	3 g/l	9.3					28 days
	Washing gel	3 g/l	9.8					28 days
	Washing up liquid	2 ml/l	7.65			not applicable		28 days
Stain remover	"Ace Gentle" type		7.7					28 days
COMBINATION	Detergent + stain remover	2 ml/l + 3 ml/l	7.7					28 days
	Detergent + softener	2 ml/l + 3 ml/l	7.7					28 days
CLEANING PRODUCTS	Floor cleaning product	8 ml/l	8.2				not applicable	28 days
	Bleach	8 ml/l	8.25			not applicable		28 days
WC CLEANERS	Toilet bowl cleaner (gel)	20 ml/l	5.45					28 days
	Drain cleaner gel	0.33 ml/l	13			not applicable		4 days
	Liquid descaler	80 ml/l	2.07					28 days

*according to the manufacturer

Recommended range for these applications: S range (see p.66)

According to the principle of continuity with no weak points, coatings for fittings and accessories must withstand the same stresses as pipes. There is an anti-corrosion coating process for these parts to ensure they can withstand major stresses, due to the fluids transported or the environment.

CATAPHORESIS

Fittings and accessories are coated with an epoxy resin deposited by cataphoresis which ensures a uniform deposit and excellent covering of edges. The optimised process by PAM Building is based on careful shotblasting and entails incorporating a chemical surface treatment during the coating cycle, between rinsing after shotblasting and the cataphoresis bath to enhance the coating's covering power.

At the end of the cycle, the parts are oven dried to complete the reticulation of the epoxy film.

Substantial improvements in:

- > The epoxy film's adhesion to the cast iron.
- > The corrosion resistance of the coated cast iron.

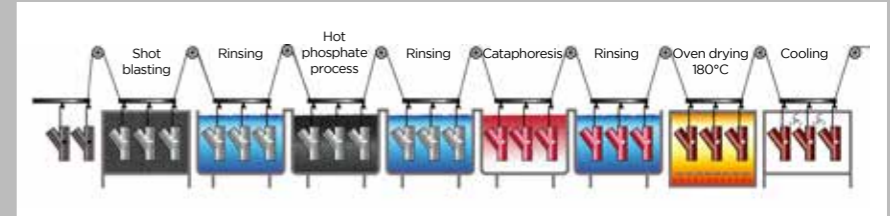



INTENSIVE USE: INTERNAL STRESSES DUE TO AGGRESSIVE EFFLUENTS

Characterisation of intense or professional uses

Aggressive effluents are characterized by their content (acids, bases, solvents, hydrocarbons, etc.), their combinations and their temperature.

- Above- and below-ground wastewater drainage for aggressive discharge are characterised by:
- > Hot water resistance: 24 h at a continuous 95°C and thermal cycles (1,500 cycles of 5 min between 15°C and 93°C)
 - > Plus range external coating corrosion resistance test to neutral salt spray according to standard NF-EN ISO 9227_2017: 2500 hours
 - > Chemical resistance: $1 < \text{pH} < 13$

Recommended range for these applications: Plus range (see p.68)

The limitation between the S and Plus ranges is only determined by the type of fluids and the operating temperature. However, the duration of daily exposure also directly determines the appropriate range to select, hence why we called this chapter intensive or professional use. The combination of high pH products (base and alkaline products) and high temperatures systematically calls for the use of the Plus range.

With its anti-corrosion thick linings, the Plus range provides greater chemical resistance and is particularly well-suited to intensive uses.

- > To transport effluents containing acids, bases or saline solutions at common operating temperatures, systematic use of the Plus range equipped with couplings with EPDM gaskets is recommended.
- > For solvents, hot oil and where hydrocarbon traces may be present, the systematic use of the Plus range equipped with couplings with NBR gaskets is recommended.

Compulsory use of PLUS range + NBR gasket				
Solvents at common temperatures of use and hot oils				
	pH	20	60	80
SOLVENTS (except Acetone)				
Ethanol, methanol, glycol				
Xylene				
White Spirit				
Gasoline, diesel, petroleum				
Lubricants, petroleum derivatives				
High temperatures OILS				

→ Plus range is compulsory

Compulsory use of PLUS range + EPDM gasket				
Acids and bases, saline solutions common temperatures of use				
	pH	20	60	80
WATER				
Salt water NaCl 30 g/l	5.6			
Demineralised water	6.6			
Wastewater	6.9			
DETERGENTS				
Cleaning supplies 10%	7.4			
Phosphate-free washing liquid	7.7			
Dishwasher cleaner 5% vol	9			
Ammonia solution 10%	9.5			
Pure ammonia solution	10			
STAIN REMOVER/OXIDANTS				
"Ace Gentle" Type 5%	4.2			
"Beckmann" Type tablet/5l	9.3			
"Blanco" Type tablet/5l	10.3			
MINERAL ACIDS				
Hydrochloric HCL 5%	1			
Sulphuric H ₂ SO ₄ 10%	1			
Sulphuric H ₂ SO ₄ 1%	2			
Phosphoric H ₃ PO ₄ 10%	1.3			
Phosphoric H ₃ PO ₄ 5%	1.8			
Phosphoric H ₃ PO ₄ 2.5%	2			
Nitric HNO ₃ 10%	2			
ORGANIC ACIDS				
Lactic 10%	1.1			
Lactic 1-5%	2.2			
Citic 5%	2			
Vinegar 30%	2.9			
Vinegar 10%	3.2			
BASES				
Soda NaOH	12			
Soda NaOH	13.6			
Ammonia NH ₃	12.1			
Potash KOH	13.6			
Bleach 10%	12			
Bleach 30%	12			
Bleach 100%	12.5			
SALTS				
KCL 3%	4.2			
NaH ₂ PO ₄ 3%	4.2			
(NH ₄) ₂ SO ₄ 3%	6.7			



→ S Range is still possible
 → Plus range is compulsory

For uses not described or intensive industrial uses, please contact our technical support team: tcbatiment.sgpam@saint-gobain.com



INTENSIVE USE: EXTERNAL STRESSES DUE TO AGGRESSIVE GROUND

Characterisation of external stresses

Below-ground wastewater drainage systems exposed to environmental stresses.

The buried section of a pipe may be laid in non-homogeneous ground or corrosive soil. When protected by galvanic effect, the pipework can be installed without requiring systematic soil studies.



Recommended range for these applications: Plus range (see p.68)

Buried systems are subjected to ground loadings which can cause shearing strain on couplings. **For these applications, it is therefore recommended to use wider couplings, and to use the “all stainless steel version” of the steel couplings** to avoid corrosion due to the aggressiveness of the ground.

INTENSIVE USE: EXTERNAL STRESSES DUE TO CLIMATE EXPOSURES

Outdoor or facade exposures

Depending on the climatic conditions, while in operation outdoor wastewater and rainwater systems can be subjected to ultraviolet radiation, saline mist, condensation, freezing-thawing cycles and pollution.

The drainage systems must be fit for purpose despite exposure to adverse conditions.

Zinc coating improves the pipes' ability to withstand climatic stresses and extends their service life.

Recommended range for these applications: Zn range (see p.70)

ZINC COATING

The zinc metal coating is an active protection provided by the galvanic action of a zinc-iron cell.

This action is two-fold:

- > Formation of a stable protective layer of insoluble zinc salts
- > Self-repairing of any damage.

Zinc metalisation is an excellent corrosion inhibitor and is extremely effective at extending the lifespan of products subject to backfills or climatic stresses.



Zinc spray

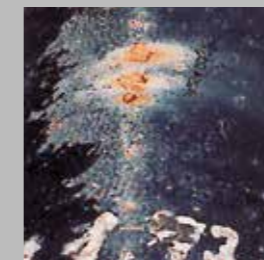

Non-zinc coated: the damage is worsened and the corrosion (red marks) extends beyond the notch



Zinc coated: a white line of zinc salt shows that the damage is completely plugged



ENVIRONMENT

Circular economy: recyclability, an exceptional asset of cast iron

03

WHY USE CAST IRON



PAM BUILDING, A KEY PLAYER IN THE CIRCULAR ECONOMY

The preservation of natural resources is a major societal challenge, especially for the construction sector, which is a major consumer of raw materials and energy. PAM Building evacuation systems are a responsible and sustainable choice, respectful of natural resources and people.

A cast iron pipe gives our waste a second life

In order to contribute to the preservation of natural resources, PAM Building's molten iron is produced by recycling cast iron and ferrous products. Unlike plastics, it can be completely and systematically recycled at the end of its life.

PAM Building's drainage solutions can be recycled without any deterioration of their properties.

The product's life cycle is also first-class in terms of environmentally-friendly logistics, long-lasting functionality (up to 70 years without compromising the mechanical properties), low maintenance costs and commercially beneficial recycling.

100% recyclable indefinitely without losing any of its properties and made from 99% recycled content*

For the standard S range, recycled content is 99% with 11.5% pre-consumer** & 87.5% post-consumer*** according to ISO 14021: 1999.

Nothing is wasted: everything is recycled

Cast iron pipe systems are based on the principle of modular ranges of removable components. Their mechanical assemblies are reversible.

You can change your mind today or even tomorrow. When pipe systems are disassembled or modified, these components can be reused, which cuts down on waste dumping.

*Recycled content: proportion, by mass, of recycled material in a product or packaging. Only pre-consumer and post-consumer materials shall be considered recycled content.

** Pre-consumer material: material diverted from the waste stream during a manufacturing process. This excludes the reuse of materials such as rework, regrind, or scrap generated in a process and capable of being reclaimed within the same process that generated it.

*** Post-consumer material: material generated by households or commercial, industrial and institutional facilities in their role as end users of the product which can no longer be used for its intended purpose.



DID YOU KNOW?

In 2021, we have recycled the equivalent of **21.000** cars.

Organised and numerous actors in the recycling channel

The recycling channel exists: **collector network and recovery stream is existing and working!**

We work with local supply for scrap (<125 km from the plant) to reduced economic and transport costs.

Following ISO 14021:1999 and LEED V4 criteria **we can provide a recycled content declaration** for our products.



ENVIRONMENT

A transparent approach: Safe products & Life Cycle Assessment

03

WHY USE CAST IRON



Life Cycle Assessment: a rigorous tool for assessing the environmental impacts of our products

Understanding the environmental performances of construction products is a growing expectation for professionals in the building chain.

In PAM Building, we strongly believe that Life Cycle Assessment is the most reliable tool available to assess the green credentials of construction products and enables companies to communicate credible, fact-based information about their products to consumers. It is also a powerful tool for enhancing the environmental features of our products. LCA is a methodology based on specific standards ISO 14040 and ISO 14044:

- > Multi-criteria tool: consumption of natural resources, air, ground and water emissions, waste generation, warming potential, ...
- > Multi-step tool: "cradle to gate" or "cradle to grave".

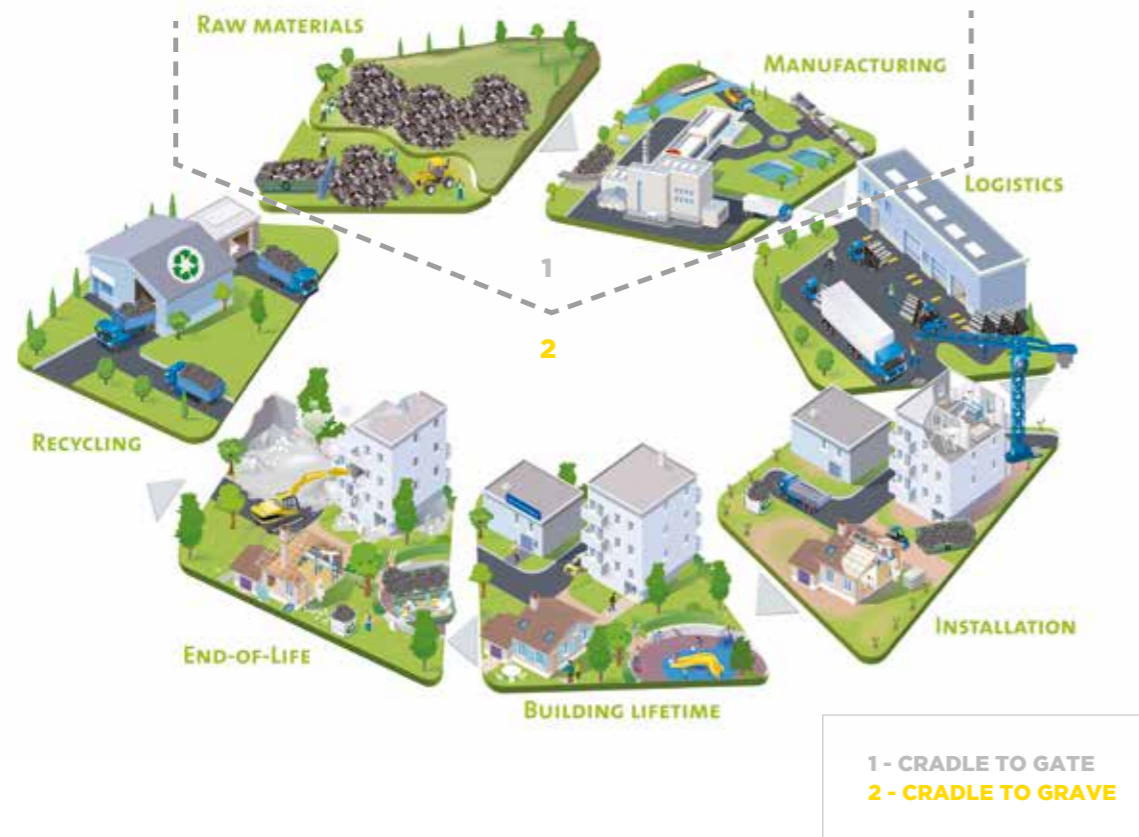

ENVIRONMENTAL PRODUCT DECLARATION

What is an Environmental Product Declaration?

The results of a LCA are presented in the form of an Environmental Product Declaration, locally administrated by program operators and based on ISO 25930 and EN 15804 standards. When an EPD has been checked by an independent third party, it is said to be verified. This process ensures the quality and reliability of the results: that is why we are committed to have verified EPDs.

We currently have produced and verified EPDs for our S and Plus ranges, both available on the Environdec platform : www.environdec.com



Overview of the EPD for our S range

This table enables a quick and synthetic overview of environmental footprint of the functional unit (1 m of SMU S cast iron pipe system for collection and drainage of waste water, sewage and rainwater in buildings), based on 70 years of lifetime. The complete EPD is available on the international Environdec platform, registration number S-P-02013.

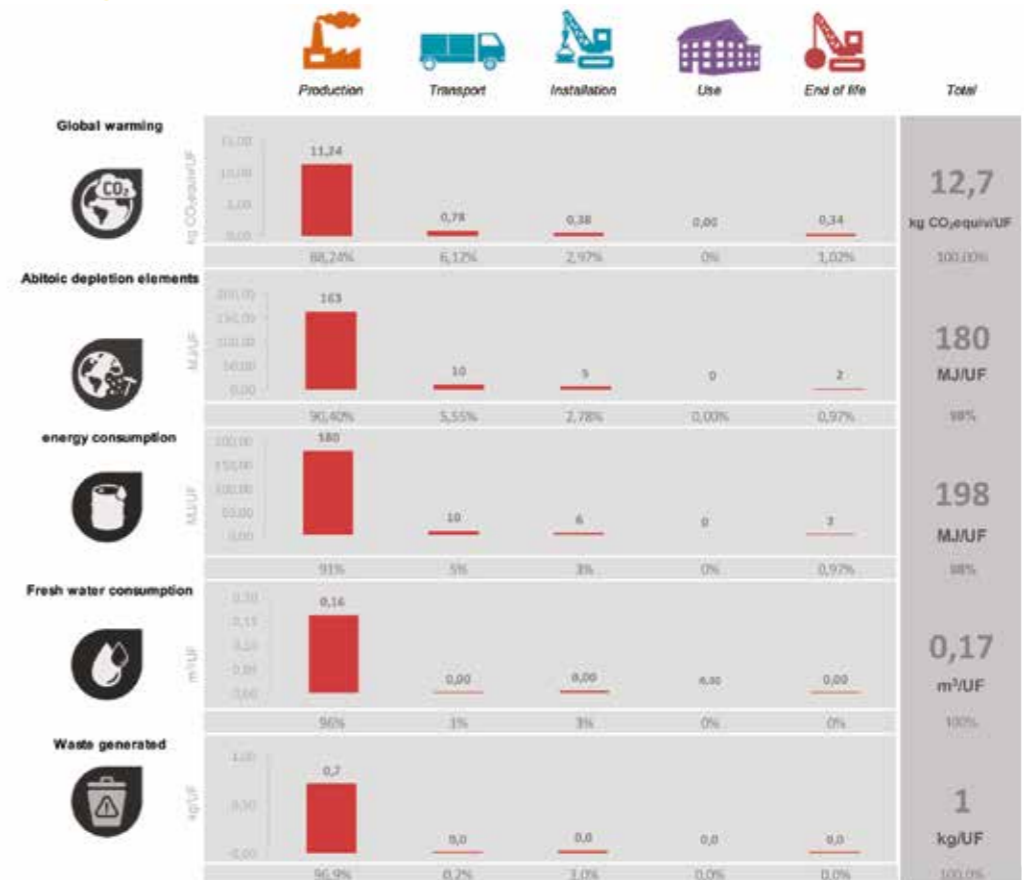

> Source: <https://www.environdec.com/Detail/?Epd=18393>

04

OUR SOLUTIONS

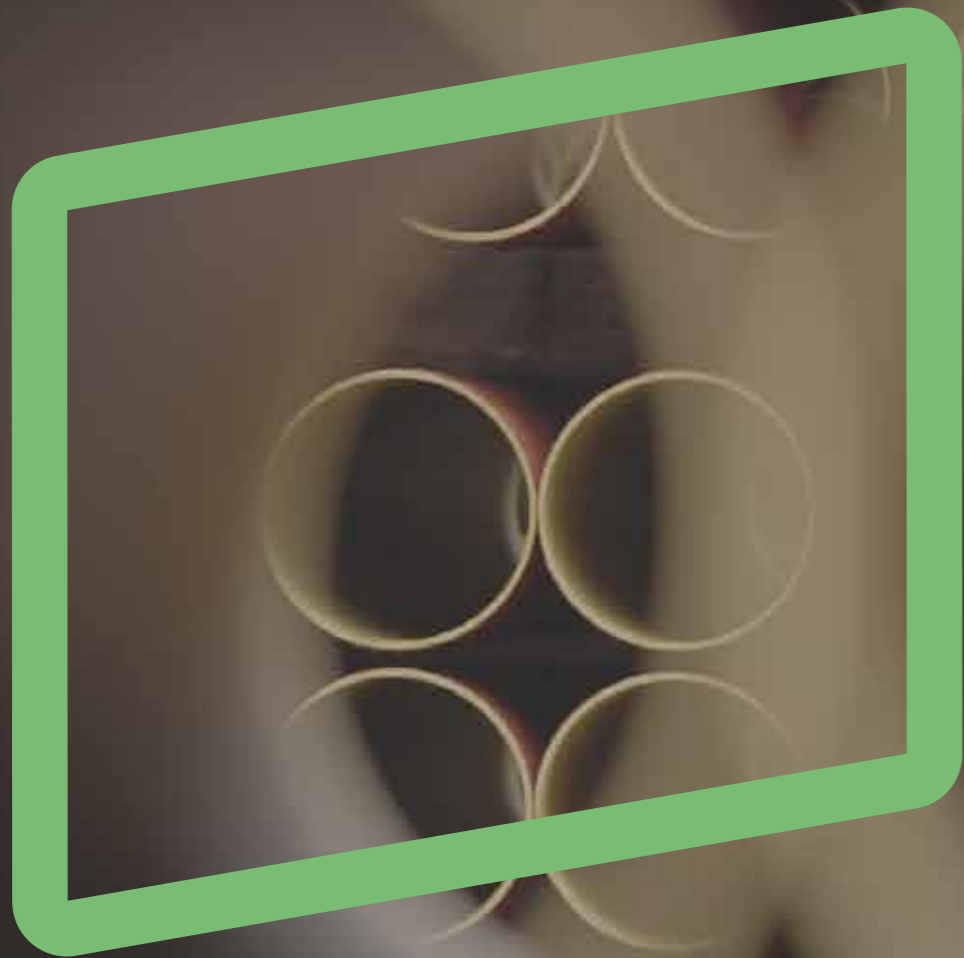

- 66 **WASTEWATER**
- 72 **RAINWATER**
- 76 **INFRASTRUCTURE**
- 78 **EARTH-TO-AIR HEAT EXCHANGER**
- 80 **COUPLINGS**

WASTEWATER: DOMESTIC USE

04

S range (details on p.86)

OUR SOLUTIONS



DESCRIPTION:

Specialised range providing complete drainage solutions for transporting fluid waste and rainwater through buildings. High-quality cast iron pipes and fittings suitable for standard use applications. This range withstands different types of domestic effluents such as grey water, black water and rainwater.

RECOMMENDED USE:

First choice for commercial, public and residential buildings, particularly medium- to high-rise buildings which require robust and safe solutions for basements and lower levels to vertical risers. Some common applications are:

- > Offices
- > Shopping centers
- > Housing
- > Airports
- > Hotels
- > Public buildings
- > Stadiums

MAJOR BENEFITS:

- > Compliant with standard EN 877
- > Performance guaranteed with marks delivered by a third party (NF, RAL-GEG, Kitemark, BBA, Sintef, Gost, Q+)
- > High level of fire safety with excellent A1 reaction to fire (non-combustible) and fire resistance up to 240 minutes depending on the configuration (generally requires no special fire protection saving time and costs).
- > Best acoustic comfort with $L_{sc,A} < 10$ dB (A) according to EN 14366
- > Ease of installation due to the mechanical couplings assembled with simple tools
- > Adaptable to all configurations with available accessories connecting cast iron with other materials
- > Limited maintenance operations thanks to the technical and mechanical properties of cast iron.

CHEMICAL AND CORROSION RESISTANCE:

- > Hot water resistance: 24 h at 95°C
- > Thermal cycle resistance: 1,500 cycles between 15°C and 93°C
- > Chemical resistance for $2 \leq \text{pH} \leq 12$.

DIMENSIONS:

- > Diameter: 50 to 400 mm (up to 600 mm on request)
- > Length: 3,000 mm.

ENVIRONMENTAL DATA:

- > Recycled content: 99%
- > 100% Recyclable.

COATINGS:

> Pipes:

- 1 External coating:** Red-brown, acrylic primer paint, average dry film thickness 40 μm .
- 2 Cast-iron** made with the De Lavaud process
- 3 Internal coating:** Two-component ochre-coloured epoxy coating, average dry film thickness of 130 μm .

> Fittings:

Externally and internally coated in red epoxy to an average thickness of 70 μm .



PRODUCT MARKING:

> Pipes:



> Fittings:



WASTEWATER: INTENSIVE USE

Plus range (details on p.108)

04

OUR SOLUTIONS



DESCRIPTION:

High-performance cast iron pipes and fittings designed to withstand intensive use. Smartly designed to drain wastewater in above- and below-ground applications when exposed to hot and/or aggressive discharge. When installed below ground in aggressive environments it is highly resistant to external stresses.

RECOMMENDED USE:

The Plus range is the first choice for hospitals, laboratories and collective kitchens.

MAJOR BENEFITS:

- > Compliant with standard EN 877
- > Performance guaranteed with marks delivered by a third party (NF, RAL-GEG, Kitemark, BBA, Sintef, Gost, Q+)
- > Long-lasting operational safety thanks to the robustness and stiffness (around 700 kN.m) of cast iron and the use of flexible mechanical couplings
- > High level of fire safety with excellent A2, s1-d0 reaction to fire and fire resistance up to 240 minutes depending on the configuration (generally requires no special fire protection, saving time and costs).
- > Best acoustic comfort with $L_{sc,A} < 10$ dB (A) according to EN 14366
- > Ease of installation due to mechanical couplings assembled with simple tools.

CHEMICAL AND CORROSION RESISTANCE:

- > Hot water resistance: 24 h at 95°C
- > Thermal cycle resistance: 1500 cycles between 15°C and 93°C
- > Chemical resistance for $2 \leq pH \leq 13$, up to 80°C (check resistance for more than 30 different effluents in the tables on p.52 and 53)
- > External coating corrosion resistance test to neutral salt spray according to standard NF-EN ISO 9227_2017: 2500 hours.

DIMENSIONS:

- > Diameter: 50 to 400 mm (up to 600 mm on request)
- > Length: 3000 mm.

ENVIRONMENTAL DATA:

- > Recycled content: 99%
- > 100% Recyclable.

COATINGS:

> Pipes:

- External coating:** Grey, acrylic primer paint, average dry film thickness of 40 μ m.
- Anti-corrosive zinc coating of 130 g/m²
- Cast-iron made with the De Lavaud process
- Internal coating:** Two-component ochre-coloured epoxy coating applied in two layers, average dry film thickness of 250 μ m.

> Fittings:

Externally and internally coated with a grey powder epoxy to an average thickness of 300 μ m.

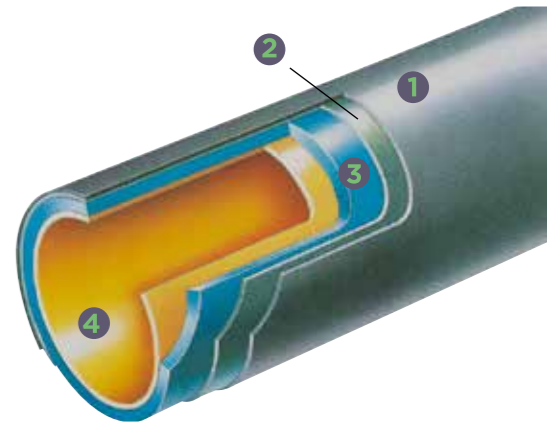

PRODUCT MARKING:

> Pipes:



> Fittings:



WASTEWATER: INTENSIVE USE

Zn range (details on p.120)

04

OUR SOLUTIONS



DESCRIPTION:

High-performance cast iron pipes designed to withstand external stresses due to climate exposures (ultraviolet radiation, saline mist, condensation, freezing-thawing cycles and pollution)

RECOMMENDED USE:

The Zn range cast iron drainage system is recommended for applications in coastal areas, directly or indirectly exposed to climatic stresses and/or polluted atmospheres, polluted or confined atmospheres such as cellars, crawl spaces or those which may be exposed to external aggressions during manufacturing processes and condensation.

MAJOR BENEFITS:

- > Compliant with standard EN 877
- > Performance guaranteed with marks delivered by a third party (NF, Watermark)
- > Resistance to climatic stresses thanks to the zinc coating, withstanding extended exposure to ultraviolet light or wide temperature variations
- > High level of fire safety with excellent A2, s1-d0 reaction to fire and fire resistance up to 240 minutes depending on the configuration (generally requires no special fire protection, saving time and costs).
- > Best acoustic comfort with $L_{sc,A} < 10$ dB (A) according to EN 14366
- > Ease of installation due to mechanical couplings assembled with simple tools.

CHEMICAL AND CORROSION RESISTANCE:

- > Hot water resistance: 24 h at 95°C
- > Thermal cycle resistance: 1500 cycles between 15°C and 93°C
- > Chemical resistance for $2 \leq \text{pH} \leq 12$
- > External coating corrosion resistance test to neutral salt spray according to standard NF-EN ISO 9227_2017: 3500 hours.

DIMENSIONS:

- > Diameter: 50 to 400 mm (up to 600 mm on request)
- > Length: 3000 mm.

ENVIRONMENTAL DATA:

- > Recycled content: 99%
- > 100% Recyclable.

COATINGS:

> Pipes:

- 1 **External coating:** red-brown, acrylic primer paint, average dry film thickness of 40 μm .
- 2 **Anti-corrosive layer:** flame-applied zinc metal coating of 260 g/m^2 on average
- 3 **Cast-iron** made with the De Lavaud process
- 4 **Internal coating:** two-component ochre-coloured epoxy coating, average dry film thickness of 130 μm .

> Fittings:

Please contact us for details of the fittings to be used with the Zn range pipes.

PRODUCT MARKING:

> Pipes:

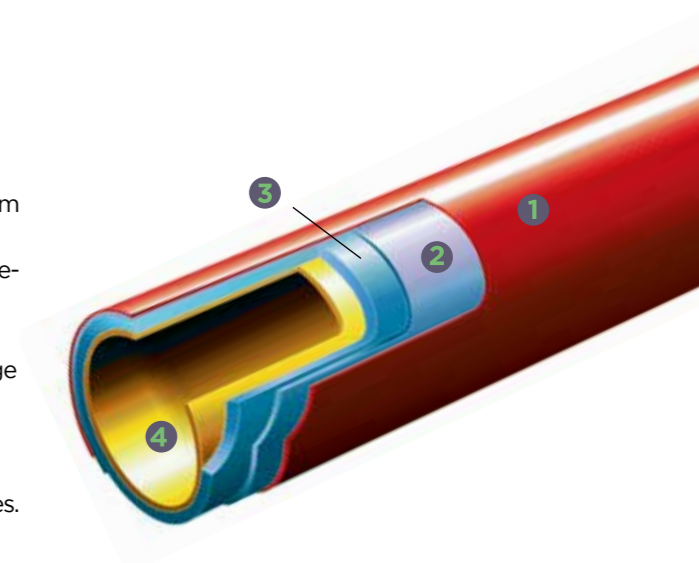
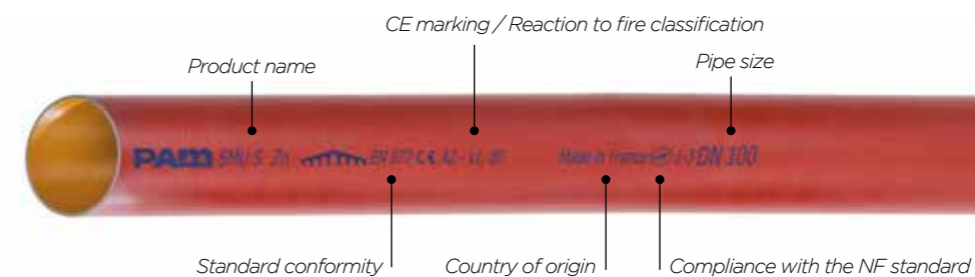

RAINWATER: GRAVITY SYSTEMS

04

Residential (Type R) (details on p.122)

OUR SOLUTIONS



MAJOR BENEFITS:

- > Compliant with standard EN 12056-3
- > Additional value to buildings due to the round or fluted aesthetic appearance of the Residential drainage solution
- > Low maintenance due to the best in class resistance to shocks and crushing
- > Long lifetime with high resistance to climatic stresses due to the zinc coating and the low thermal expansion coefficient of cast iron
- > High level of fire safety with excellent A1 reaction to fire (non-combustible)
- > Ease of installation due to the push-fit assembly system.

DIMENSIONS:

- > Diameter: 75 - 100 - 125 mm
- > Length: 1000 and 2000 mm

ENVIRONMENTAL DATA:

- > Recycled content: 99%
- > 100% Recyclable.

COATINGS:

> Pipes:

- 1 **External coating:** light beige colour (RAL 7032), water-based coating of 40 µm.
- 2 **Anti-corrosive layer:** flame-applied zinc metal coating of 130 g/m² in average
- 3 **Cast-iron** made with the De Lavaud process
- 4 **Internal coating:** water-based coating of 40 µm.

> Fittings:

Cataphoresis 70 µm + water-based coating 40 µm.

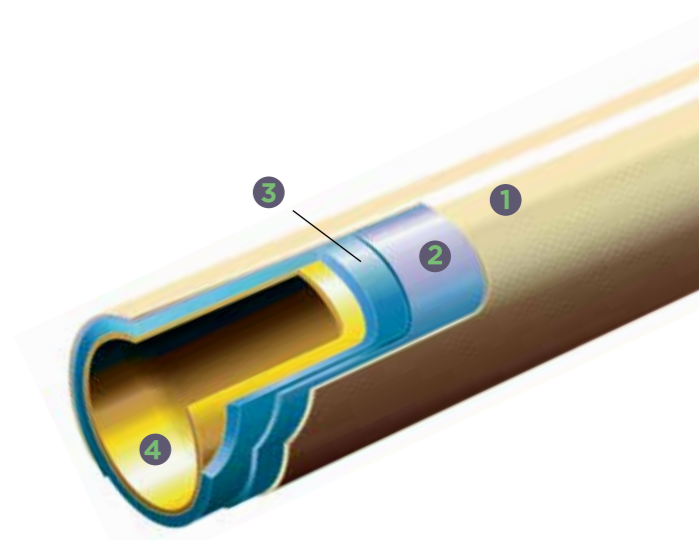

MECHANICAL RESISTANCE:

> Shock resistance:



The test consists of dropping a mass of 2.75 kg on a descent at increasing heights until it breaks or cracks.

The average height of the fall for Residential (Type R) is 2 to 5 times higher than for other products. Up to an average drop height of 2 m, the Residential (Type R) deforms while the other products have cracked.

> Crushing resistance:

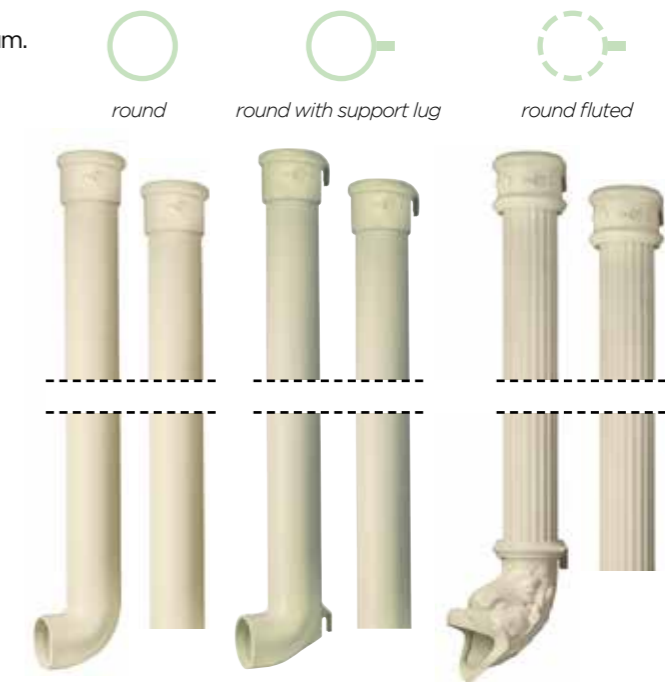
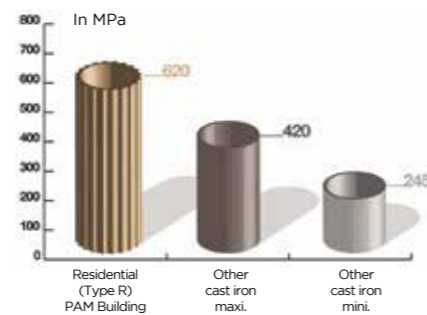

RAINWATER: SIPHONIC SYSTEM

EPAMS® (details on p.128)

04

OUR SOLUTIONS

HOW IT WORKS?

The EPAMS® system is a combination of cast iron pipes, fittings and accessories, jointed with PAM couplings able to withstand a negative pressure of -900 mbar.



EPAMS® outlets are equipped with an anti-vortex mechanism that prevents air from entering the pipes at rainwater inlets. The absence of air then causes an acceleration of the flow by creating a negative pressure.

MAJOR BENEFITS:

- > System under French Technical Approval EPAMS® 5+14.14-2
- > Suitable for all ambitious architecture and all roof types*
- > Cost-efficiency via savings on purchases and installation costs: fewer downpipes than gravity systems
- > Suitable for all areas and rainfall: high volumes of water drained up to 75 l/s
- > Low and easy maintenance with a durable system: no claim since its launch (1994)

TECHNICAL SUPPORT:

- > Technical study and network sizing provided by PAM Building through the dedicated EPAMS® software
- > 2D and 3D design available
- > Job site inspection

INSTALLATION:

- > See p.172

*For more details please consult French Technical Approval EPAMS® 5+14.14-2 or contact us: tcbatiment.sgpam@saint-gobain.com

DIMENSIONS:

- > Diameters : 50 - 75 - 100 - 125

PRODUCT RANGE:



> EPAMS® outlet to be welded

Application field: This roof outlet is especially designed to be welded (or brazed) in gutters or metal roof valleys.

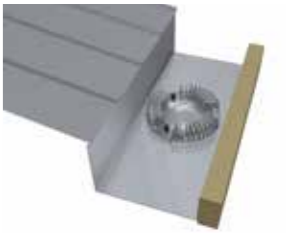

> EPAMS® outlet with flange

Application field: This roof outlet can be used for roofs containing extra-thick metal gutters or valleys as well as for roofs waterproofed by synthetic or bituminous membranes.

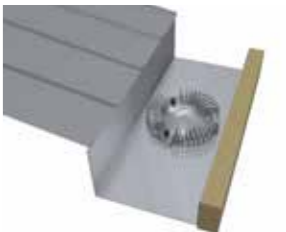

> EPAMS® outlet with steel plate

Application field: This roof outlet is used on all the roofs mentioned within the scope of the French Technical Assessment 5+14/14-2386, except those with waterproofing by a synthetic membrane.

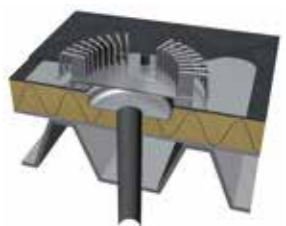

> EPAMS® outlet for flexible PVC membrane

Application field: This roof outlet is used on non-accessible roofs and/or with equipment zones, and waterproofed by synthetic PVC-P membranes depending on the manufacturer's technical assessment. Waterproofing is provided by a weld between the various PVC elements to seal them in a traditional way. The membrane may be visible or may be given heavy mineral protection. For the latter case, it is possible to use gravel > 15 mm, but the roof outlet must be fitted with an elevating kit for the anti-vortex mechanism.

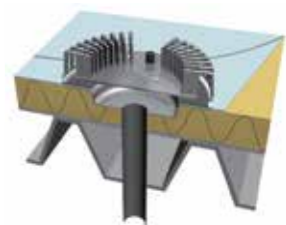



DESCRIPTION:

The Itinero® range is a solution that meets the high drainage technical demands of infrastructure projects. Itinero® is a dedicated range which factors in the specificities of a project and guarantees excellent performance to accommodate different stress levels (weather constraints or exposures).

RECOMMENDED USE:

It is recommended for collecting and draining surface water from bridges, tunnels and viaducts, for new builds or renovation projects.

MAJOR BENEFITS:

- > Compliant with standard EN 877
- > Performance guaranteed with marks delivered by a third party (NF)
- > Long lifetime with high resistance to climatic stresses due to the zinc coating and low thermal expansion coefficient of cast iron
- > Low maintenance due to the best in class resistance to shocks and crushing
- > High level of fire safety with excellent A2,s1-d0 reaction to fire (non-combustible)
- > Suitable for many bridge and tunnel designs and adapted to renovation projects
- > Easy to install due to mechanical couplings assembled with simple tools.

TECHNICAL SUPPORT :

- > We provide design recommendations, discharge system set-up and a bill of quantities for your project. Contact us at: tcbatiment.sgpam@saint-gobain.com

CHEMICAL AND CORROSION RESISTANCE:

- > Hot water resistance: 24 h at 95°C
- > Thermal cycle resistance: 1,500 cycles between 15°C and 93°C
- > Chemical resistance for $2 \leq \text{pH} \leq 12$
- > External coating corrosion resistance test to neutral salt spray according to standard NF-EN ISO 9227_2017: 4500 hours.

DIMENSIONS:

- > Diameter : 100 to 600 mm
- > Length : 3000 mm

ENVIRONMENTAL DATA:

- > Recycled content: 99%
- > 100% Recyclable.

COATINGS:

> Pipes:

- 1 **External coating:** Grey (approximate RAL 7030), epoxy coating, average dry film thickness of 80 µm
- 2 Anti-corrosive zinc coating of 260 g/m² (about 40 µm)
- 3 Cast-iron made with the De Lavaud process
- 4 **Internal coating:** epoxy coating, average dry film thickness of 130 µm.

> Fittings:

Externally and internally coated with a mat grey powder epoxy (approximate RAL 7030), to an average thickness of 300 µm.

PRODUCT MARKING:

> Pipes:



> Fittings:

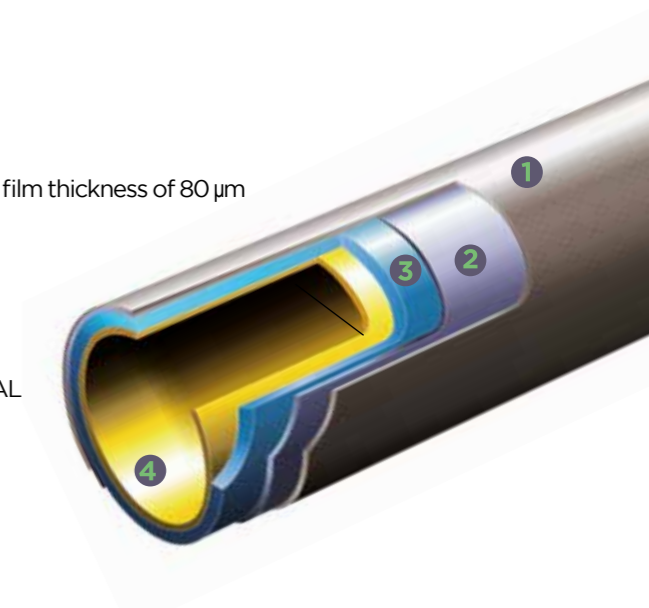

EARTH-TO-AIR HEAT EXCHANGER

Elixair® Range available on request

04

OUR SOLUTIONS

HOW IT WORKS?

An earth-to-air heat exchanger (EAHX) is a surface geothermal solution for buildings, involving a buried pipe system which circulates fresh air.

It aims to warm up fresh air in buildings in winter and cool it down in summer. Based on thermal air-to-ground exchanges, it is a passive solution.

Where installed, the earth-to-air heat exchanger plays an active role in the building's thermal comfort.

ELIXAIR® by PAM is a comprehensive offer, designed to build earth-to-air heat exchangers combining safety and efficiency with ductile iron products.

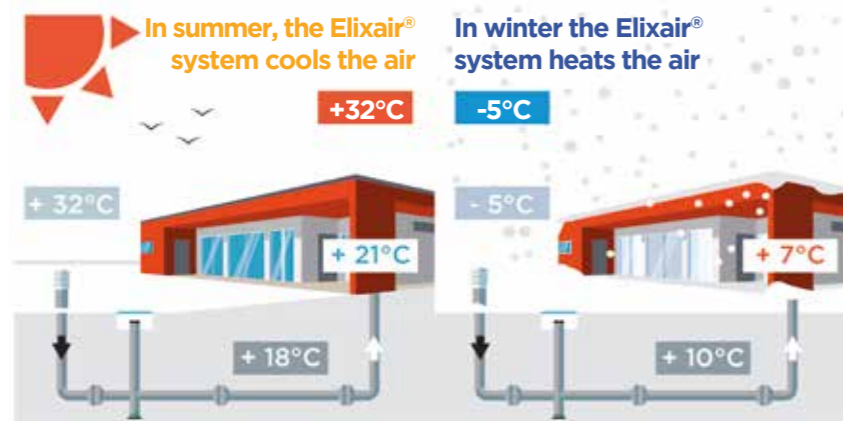
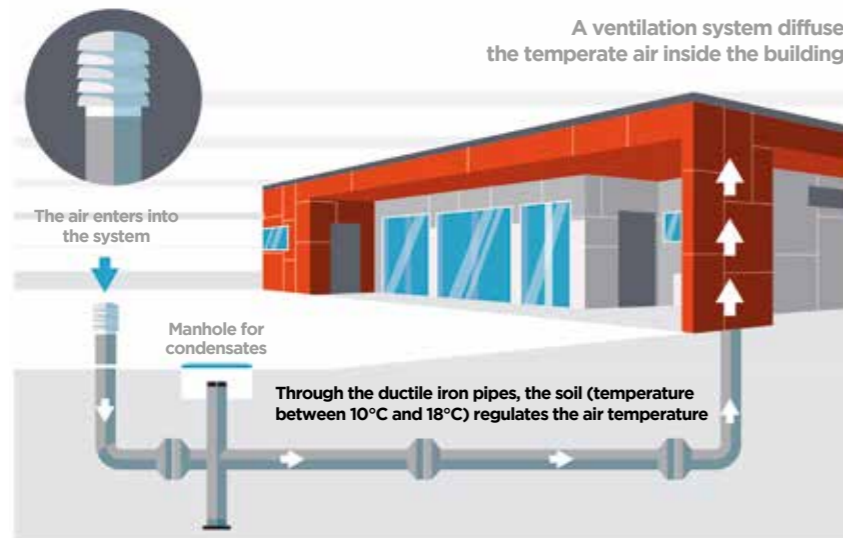

RECOMMENDED USE:

- > Public buildings
- > Commercial and industrial buildings
- > Farm buildings

MAJOR BENEFITS:

- > System under French Technical Approval 14/14-2056 CSTB
- > Energy savings thanks to the complete system and the high thermal conductivity of ductile iron
- > Resistance to ground loading and traffic: ductile iron pipe systems can be buried deep without damage, also under areas which are driven over or car parks
- > Withstands rustic laying conditions allowing backfill with the extracted materials
- > Excellent air tightness due to Express or Standard couplings working under compression
- > Durability: as for all buried systems, strength and long-lasting properties are key factors to avoiding premature replacements.

THERMAL PERFORMANCES:

- > In winter: in-out average temperature difference = 7 to 12°C
- > In summer: in-out average temperature difference = 7 to 16°C

TECHNICAL SUPPORT:

Send us your project and we will be able to help you with the supply of:

- > Your earth-to-air heat exchanger
- > The bill of quantities
- > The heat energy saved in winter
- > The cooling energy saved in summer

Contact us: tcbatiment.sgpam@saint-gobain.com



COUPLINGS MAIN FEATURES

A coupling is made of several components: casing, screws, barrel and gasket as described in the drawing.



SEVERAL GRADES OF STEEL

We follow a global material designation for steel components of the coupling described in the following table.

Material designation*

		DIN	AISI
W2	Screw and nut	Coated steel class 8.8	
	Barrels	1.4510	430Ti
	Casing or strap	1.4510	430Ti
W4	Screw	1.4404	316L
	Barrels	1.4401	316
	Casing or strap	1.4301	304
W5	Screw	1.4404	316L
	Barrels	1.4401	316
	Casing or strap	1.4404	316L

*Please refer to datasheet for specific information as some material may differ depending on the coupling design.

ELASTOMERIC GASKETS

The choice of the elastomeric gasket is related to the nature of the effluent.
 EPDM: **EPDM** rubber is suitable for most types of effluents.
 NBR: **Nitrile Butadiene Rubber** is recommended for wastewater and runoff water liable to contain hot oil, solvents or hydrocarbons. They are recommended for infrastructure applications.

COUPLING SELECTION GUIDE

		Type of network				
		Aerial network	In concrete	External stresses*	Burried network A	Infrastructure B
Type of effluent	Wastewater 1	S range W2 W4 EPDM		Zn range W5 EPDM	Itinero® W5 EPDM	
	Rainwater 2			Plus range W5 EPDM		
	Agressive effluents 3	Plus range W2 W4 EPDM		Plus range W5 EPDM	Itinero® W5 NBR	
	Hydrocarbon runoff water 4			Plus range W2 W4 NBR		

*ie. Climate exposure; pollution, sea-side



We provide a large range of couplings to match all building specifications. Our products are available in different versions to withstand all types of effluents, pressures and external stresses.

STANDARD COUPLINGS

PAM Rapid (p.134)



The single-bolt PAM Rapid coupling allows fast and reliable installation. It ensures optimized watertightness, pressure and corrosion resistance.

MAJOR BENEFITS:

- > Compliant with standard EN 877
- > Ease of installation
- > Suitable for projects with effluents containing solvents, hydrocarbons (i.e. car parks), due to the availability of the NBR version (nitrile gasket)

MATERIAL:

- > **Main material:** W2 or W5 (AISI 316L)
- > **Gasket:** EPDM or NBR

PRESSURE RESISTANCE:

- > Exceeds the EN 877 requirements - DN 50 to 125: 10 bar / DN 150 to 200: 5 bar / DN 250 to 300: 3 bar.

PAM R (p.135)



"R" for Repair: this coupling is particularly suited to repairs and retrofits. It is installed in two separate parts.

MAJOR BENEFITS:

- > Compliant with standard EN 877
- > Full opening strap particularly suited to renovation projects

MATERIAL:

- > **Main material:** W5 (AISI 316L)
- > **Gasket:** EPDM

PRESSURE RESISTANCE:

- > Exceeds the EN 877 requirements - DN 50 to 125: 10 bar / DN 150 to 200: 5 bar.

HIGH PRESSURE COUPLINGS



PAM HP FLEX coupling

(p.136)

PAM HP FLEX couplings withstand up to 10 bar of hydrostatic pressure for most diameters. These couplings are used for straight runs where the pressures can occur.

MAJOR BENEFITS:

- > Compliant with standard EN 877
- > The solution for large-diameter networks (>300 mm)

MATERIAL:

- > **Main material:** W4 (AISI 304) or W5 (AISI 316L)
- > **Gasket:** EPDM or NBR

PRESSURE RESISTANCE:

- > Exceeds the EN 877 requirements - DN 100 to 400: 10 bar / DN 500 and DN 600: 6 bar



PAM HP GRIP coupling

(p.137)

In sections where end thrust efforts have to be addressed, the autogrip couplings are alternative solutions for securing junctions whilst addressing pressure. The PAM HP GRIP couplings are self-anchored couplings with built-in claw rings.

MAJOR BENEFITS:

- > Compliant with standard EN 877
- > The 2-in-1 solution: coupling and grip collar with only one product
- > Particularly suited to EPAMS® installation

MATERIAL:

- > **Main material:** W4 (AISI 304) or W5 (AISI 316L)
- > **Gasket:** EPDM or NBR

PRESSURE RESISTANCE:

- > Exceeds the EN 877 requirements - DN 100 to 400: 10 bar / DN 500 and DN 600: 4 bar

05

PRODUCT CATALOG



- 86 **WASTEWATER**
 - › Domestic use: P AM-GLOBAL® S
 - › Intensive use: PAM-GLOBAL® Plus, SMU Zn

- 122 **RAINWATER**
 - › Gravity systems: Residential (Type R)
 - › Siphonic systems: EPAMS®

- 130 **INFRASTRUCTURE**
 - › Itinero®

- 134 **COUPLINGS, COLLARS & CONNECTORS**

- 142 **SUPPORTING & FIXING SYSTEMS**

- 145 **ACCESSORIES**

PAM-GLOBAL® S - PIPES



DN	L	H	W	Weight	Product code
50	3000	58	58	12.9	156361
75	3000	83	83	18.8	156550
100	3000	110	110	25.1	156561
125	3000	135	135	35.3	156734
150	3000	160	160	42.1	156825
200	3000	210	210	69.1	156949
250	3000	274	274	99.5	157048
300	3000	326	326	129.4	157113
400	3000	429	429	179.5	157171
	2800	429	429	167.5	216735

* For dimensions over DN 400 please contact us.



PAM-GLOBAL® S - FITTINGS

> BENDS | Short radius bends

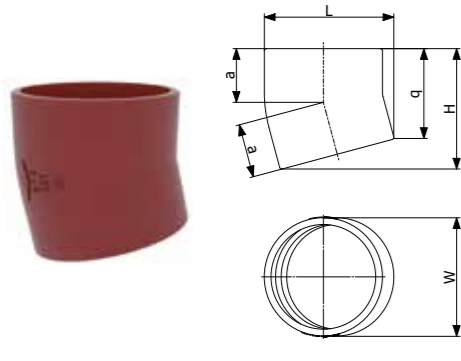

15° BENDS

DN	L	H	W	a	q	Weight	Product code
50	66	80	58	40	66	0.4	155752
75	93	99	83	45	78	0.68	176702
100	121	112	110	50	83	1	155816
125	148	134	135	60	99	1.7	155870
150	173	148	160	65	108	2.5	155903
200	227	184	210	80	129	4.6	155932

"All dimensions are in mm and nominal weights are in kg"

> BENDS | Short radius bends

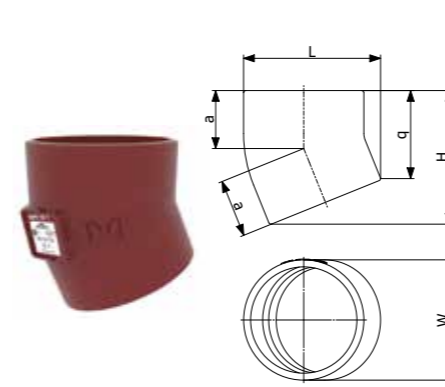

22° BENDS

DN	L	H	W	a	q	Weight	Product code
50	70	88	58	40	66	0.45	156388
75	97	105	83	47	74	0.8	156480
100	126	125	110	54	84	1.3	156598
125	152	143	135	61	92	1.9	156761
150	179	162	160	69	102	2.6	156855
200	233	200	210	83	122	4.4	156974
250	300	240	274	100	138	9.5	157071
300	356	279	326	115	157	15.3	157136
400	466	324	429	142	177	23.7	170730

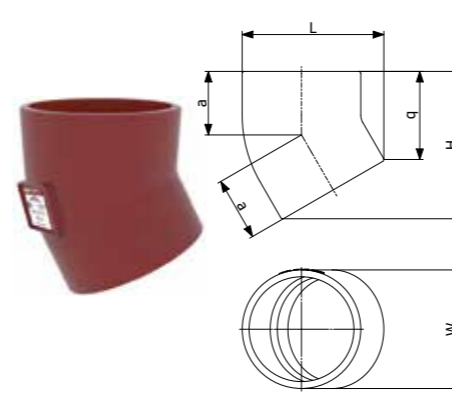

30° BENDS

DN	L	H	W	a	q	Weight	Product code
50	76	97	58	45	69	0.5	155753
75	102	114	83	50	73	0.8	176703
100	132	136	110	60	81	1.3	155817
125	160	164	135	70	96	2	155871
150	189	188	160	80	108	3	155904
200	243	229	210	95	124	5.4	155933
250	309	270	274	110	133	9.7	155948
300	367	322	326	130	159	15.5	155960
400	478	369	429	184	173	26	170731

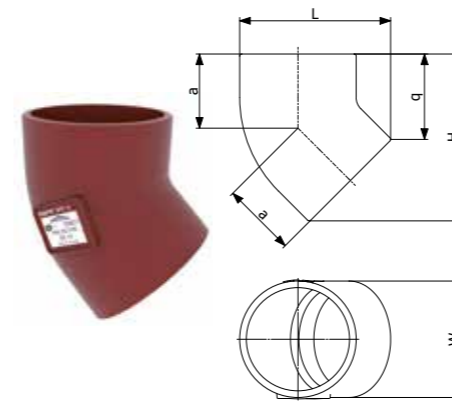

45° BENDS

DN	L	H	W	a	q	Weight	Product code
50	84	106	58	50	65	0.6	155751
75	112	132	83	60	73	0.9	176704
100	142	158	110	70	80	1.6	155815
125	171	184	135	80	89	2.1	155869
150	199	210	160	90	97	3.2	155902
200	256	262	210	110	113	5.3	155931
250	324	319	274	130	125	10	155947
300	387	380	326	155	149	18.3	155959
400	540	573	429	247	270	34.4	157175

* For dimensions over DN 400 please contact us.

"All dimensions are in mm and nominal weights are in kg"

> BENDS | Short radius bends

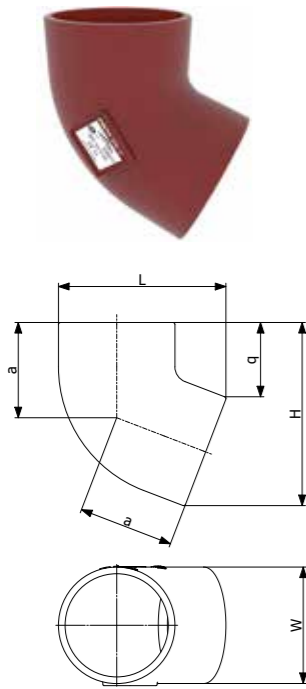

68° BENDS

DN	L	H	W	a	q	Weight	Product code
50	104	123	58	65	70	0.8	155750
75	131	149	83	80	72	1	176705
100	159	176	110	90	74	1.8	155814
125	188	205	135	105	80	3	155868
150	219	237	160	120	89	4.1	155901
200	277	295	210	145	99	7.8	156968

> BENDS | Long radius bends



88° BENDS

DN	L	H	W	a	b	Weight	Product code
100	324	324	110	269	230	4.2	156606
150	349	349	160	274	210	8	156860

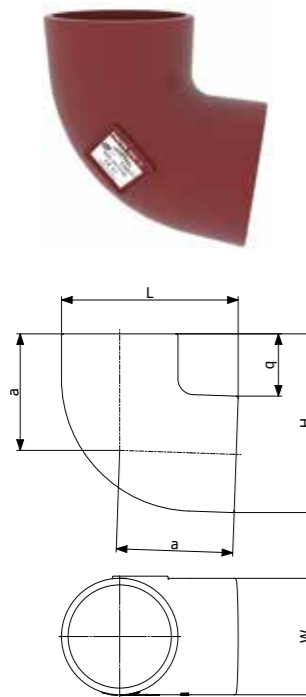
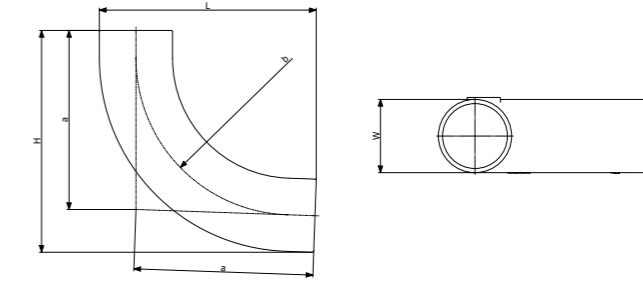

88° BENDS

DN	L	H	W	a	q	Weight	Product code
50	104	107	58	75	49	0.8	155749
75	138	140	83	95	57	1.4	176706
100	166	169	110	110	59	2.2	155813
125	194	197	135	125	62	2.9	155867
150	227	230	160	145	70	4.3	155900
200	288	291	210	180	81	8.1	155930
250	360	363	274	223	89	13.5	157065
300	427	431	326	280	105	27.7	157130
400	644	651	429	466	223	59	245567



135° BENDS

DN	L	H	W	o	p	Weight	Product code
100	314	272	110	236	100	4.5	155818

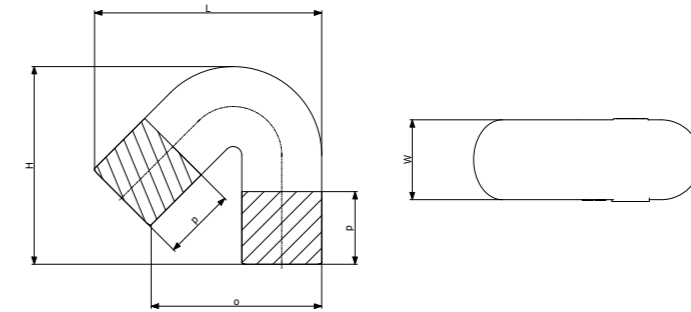

> BENDS | Long tail bends



45° BENDS

DN	L	H	W	a	b	o	q	Weight	Product code
100	338	143	110	250	250	180	260	3.5	155824

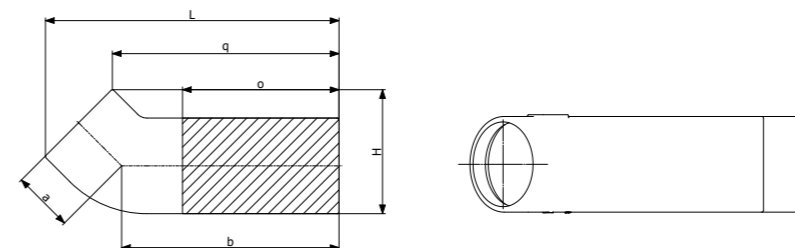

"All dimensions are in mm and nominal weights are in kg"

"All dimensions are in mm and nominal weights are in kg" - "Hatch patterned area in the drawings shows the max. cutting length".

> BENDS | Long tail bends



88° BENDS

DN	L	H	W	a	b	o	q	Weight	Product code
100	305	165	110	110	250	140	195	3.7	155823

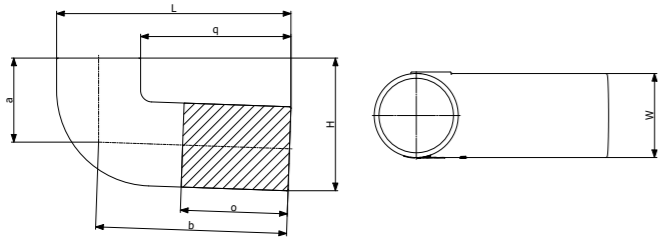

> BENDS | 88° Double bends



DN	L	H	W	a	b	c	o	Weight	Product code
50	148	148	58	121	50	100	148	1	155754
75	183	183	83	145	60	120	183	1.5	176707
100	228	228	110	170	70	140	228	2.8	155819
125	265	265	135	195	80	160	265	4.4	155872
150	303	303	160	219	90	180	303	6.3	155905

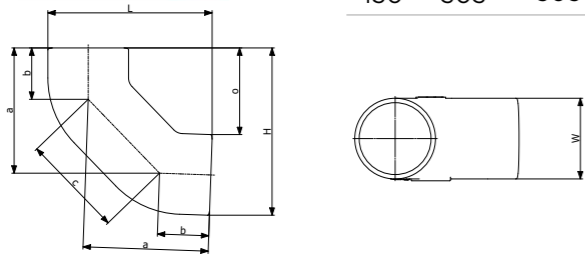

> BENDS | 88° Long tail double bends



DN	L	H	W	a	b	c	Weight	Product code
75	315	315	83	273	60	301	2.9	179679
100	346	346	110	291	70	312	4.8	155820
125	376	376	135	308	80	322	6.1	155873
150	406	406	160	326	90	334	9.0	155906

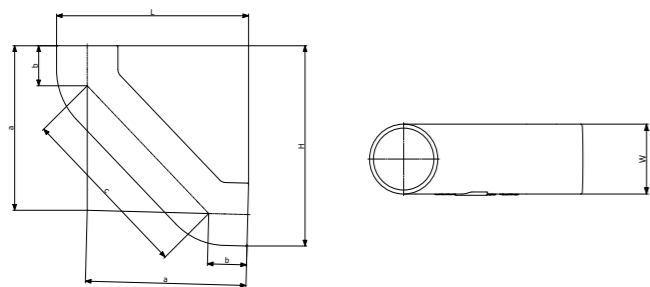

"All dimensions are in mm and nominal weights are in kg" - "Hatch patterned area in the drawings shows the max. cutting length".

> BENDS | Offsets



DN	L	H	W	b	c	Weight	Product code
100	175	205	110	65	70	2	155812
	240	270	110	130	70	3.7	155821
	310	340	110	200	70	4.2	155822

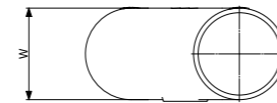
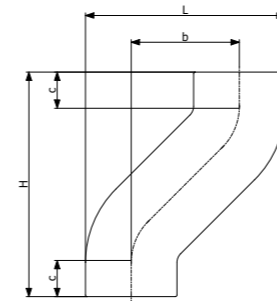

> BENDS | 88° Vented bends

DN	Ventilation	L	H	W	p	q	r	Weight	Product code
100	Radial	166	169	150	95	59	110	2.15	157581
100	Axial	200	169	110	166	59	110	2.15	156585

Radial

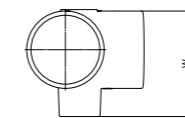
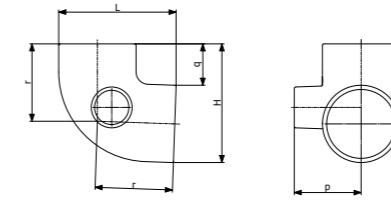

Axial

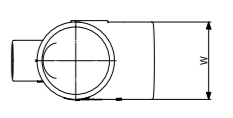
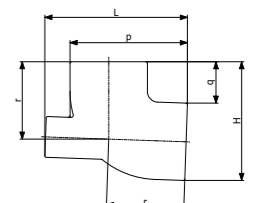

"All dimensions are in mm and nominal weights are in kg"

> BRANCHES | Single branches

45° BRANCHES

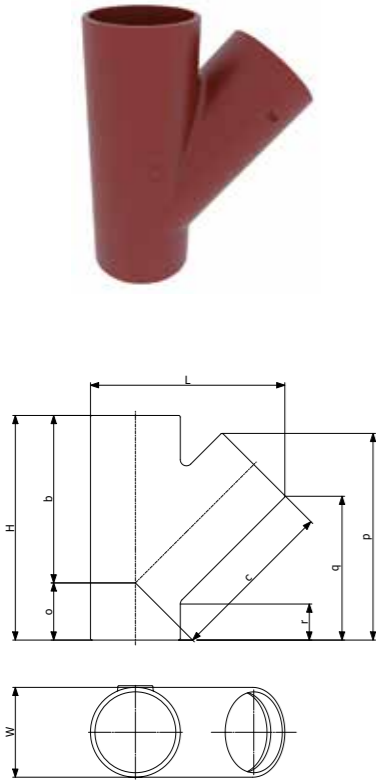

DN	dn	L	H	W	b	c	o	p	q	r	Weight	Product code
50	50	144	185	58	135	135	50	165	124	36	1.35	155769
75	50	156	180	83	135	135	45	161	120	43	1.6	173786
	75	179	215	83	155	155	60	198	140	40	2.2	173787
100	50	191	200	110	165	165	35	172	131	47	2.4	155828
	75	214	235	110	170	170	50	209	151	46	3.2	173788
100	100	238	275	110	205	205	70	253	175	45	4	155857
	50	218	205	135	185	185	20	170	130	44	3.2	155877
125	75	237	240	135	195	200	45	215	156	51	4.2	176716
	100	261	280	135	220	220	60	254	177	47	5	155882
125	125	284	320	135	240	240	80	296	201	49	5.2	155895
	75	265	255	160	210	220	35	220	161	54	5.1	176733
150	100	287	295	160	240	240	55	262	185	54	5.8	155912
	125	307	325	160	255	255	70	298	202	52	7.4	155914
150	150	323	355	160	265	265	90	333	219	53	7.9	155926
	75	303	260	210	240	240	20	218	159	64	7.4	176734
200	100	340	310	210	265	265	40	275	198	67	9.3	155935
	125	360	340	210	280	280	55	310	215	64	11.6	155936
200	150	383	375	210	300	300	75	353	240	66	12.3	155937
	200	418	455	210	340	340	115	428	280	68	17.1	155944
250	100	398	330	274	315	315	15	276	198	72	13.6	155949
	125	420	370	274	335	335	35	318	223	75	17.8	155950
250	150	440	405	274	350	350	55	358	245	75	22	155951
	200	486	480	274	390	390	90	440	291	75	22.4	155952
250	250	537	580	274	430	430	130	530	335	70	29	155956
	100	445	350	326	345	345	5	287	208	88	18.9	155961
300	125	464	360	326	360	360	15	316	221	80	22.7	155962
	150	487	415	326	380	380	35	359	246	81	28	155963
300	200	547	485	326	415	440	70	454	305	81	31	155964
	250	588	580	326	465	465	115	540	347	80	37.6	155965
300	300	634	660	326	505	505	155	661	431	115	46.3	155968
	400	728	660	429	555	555	105	620	389	86	56.4	157178
400	400	820	835	429	645	645	190	795	492	101	98	157185

* For dimensions over DN 400 please contact us.

"All dimensions are in mm and nominal weights are in kg"

68° BRANCHES

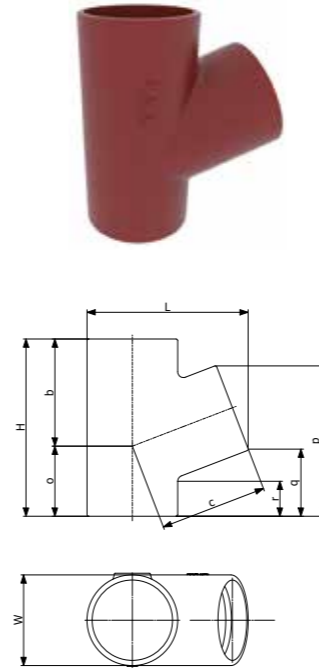

DN	dn	L	H	W	b	c	o	p	q	r	Weight	Product code
50	50	118	145	58	80	80	55	117	65	37	1	156433
75	50	140	155	83	95	95	60	122	69	42	1.4	156488
	75	158	180	83	110	110	70	149	72	37	2	156542
100	50	168	155	110	100	110	55	123	69	43	2	156616
	75	186	185	110	115	125	70	155	79	44	2.6	156623
100	100	195	220	110	130	130	85	189	87	50	2.8	156699
	50	189	165	135	110	120	55	126	72	50	2.6	on request
125	100	222	225	135	140	145	85	190	88	50	3.9	156773
	125	235	255	135	155	155	100	220	95	50	4.5	156811
150	100	243	235	160	150	155	85	194	92	55	4.8	156877
	125	262	265	160	165	170	100	226	101	56	5.7	156881
150	150	276	295	160	180	180	115	256	108	55	6.5	156929
	100	296	260	210	175	185	85	205	102	67	7.2	on request
200	150	329	310	210	200	210	110	263	114	62	8.5	156987
	200	352	365	210	225	225	140	321	126	63	12	157027
250	200	420	390	274	255	265	135	428	132	68	18.3	157076
	250	452	460	274	285	285	170	408	154	77	21.1	157104
300	300	544	545	326	345	345	170	430	178	80	33.4	157167

88° BRANCHES

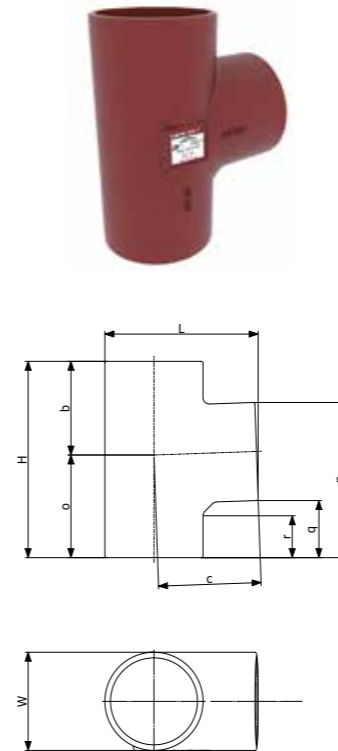

DN	dn	L	H	W	b	c	o	p	q	r	Weight	Product code
50	50	110	145	58	66	80	79	111	53	31	1	155767
75	50	132	160	83	75	90	85	117	59	42	1.5	176718
	75	138	180	83	85	95	95	140	57	37	1.6	176719
100	50	161	170	110	76	105	94	127	69	45	2	155827
	75	166	190	110	90	110	100	145	62	40	2.4	176720
100	100	172	220	110	105	115	115	174	64	41	2.8	155855
	50	188	180	135	82	120	98	131	73	51	2.6	155876
125	75	194	205	135	100	125	105	151	68	48	2.9	176722
	100	199	235	135	110	130	125	184	74	48	4.2	155880
125	125	205	260	135	123	135	137	209	74	48	5	155894
	50	221	200	160	100	140	100	134	76	51	3.9	155908
150	75	221	220	160	105	140	115	161	78	55	4.4	176723
	100	227	245	160	115	145	130	190	80	52	5.6	155911
150	125	232	275	160	128	150	147	220	85	56	6.1	155913
	150	237	300	160	142	155	158	243	83	55	6.7	156925
200	100	282	270	210	125	175	145	206	96	64	8.8	156980
	200	388	365	210	172	183	193	296	86	67	11	157024
250	250	366	455	274	228	243	240	375	101	77	19.5	157102
300	300	434	530	326	265	265	265	437	111	87	35	157165
400	400	616	684	429	314	370	370	595	165	90	67	170732

"All dimensions are in mm and nominal weights are in kg"

> BRANCHES | Long tail single branches



45° BRANCHES

DN	dn	L	H	W	b	c	d	e	p	q	r	Weight	Product code
100	100	238	430	110	205	205	225	170	424	346	241	5.3	156723
150	150	323	705	110	265	265	440	350	684	571	403	18.3	156938
200	200	423	770	110	340	346	430	320	749	600	383	26	157036

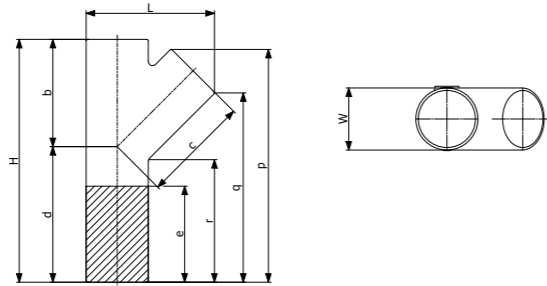

68° BRANCHES

DN	dn	L	H	W	b	c	d	e	p	q	r	Weight	Product code
100	100	195	460	110	130	130	330	250	430	328	290	4.8	156721

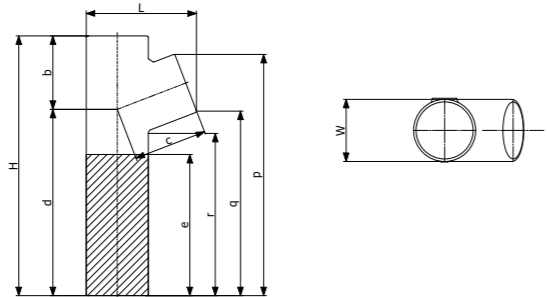

88° BRANCHES

DN	dn	L	H	W	b	c	d	e	p	q	r	Weight	Product code
100	100	177	430	110	105	115	325	210	274	269	254	4.7	155861

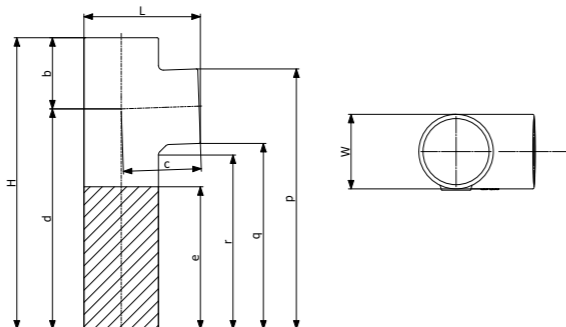

"All dimensions are in mm and nominal weights are in kg" - "Hatch patterned area in the drawings shows the max. cutting length".

> BRANCHES | Double branches

> Short double branches



45° BRANCHES

DN	dn	L	H	W	b	c	d	p	q	r	Weight	Product code
100	100	346	260	110	190	190	70	243	165	46	5.3	156709
125	100	387	280	135	220	220	60	254	177	50	6.3	257729
	125	421	305	135	240	240	65	285	190	45	7.9	156817
150	100	394	280	160	225	225	55	252	174	54	7.3	156865
	150	488	355	160	265	265	90	334	277	55	11.8	156936
200	200	627	455	210	340	340	115	428	280	67	18.4	157034

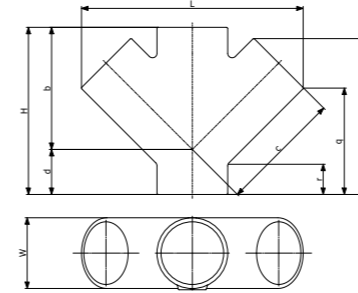

68° BRANCHES

DN	dn	L	H	W	b	c	d	p	q	r	Weight	Product code
50	50	178	145	58	85	85	60	118	64	35	1.2	156437
75	75	234	180	83	110	110	70	149	72	36	2.3	156546
100	75	262	185	110	115	125	70	155	79	44	3	156609
	100	281	220	110	130	130	85	189	87	50	3.4	156707
125	100	309	225	135	140	145	85	190	88	50	4.4	156766
	125	336	255	135	155	155	100	220	95	51	5.5	156815
150	125	364	265	160	165	170	100	226	101	56	6.6	156867
	150	392	295	160	180	180	115	256	108	57	8.2	156934
200	150	448	310	210	200	210	110	259	110	58	10.7	156978
	200	494	365	210	225	225	140	321	126	67	14	157032

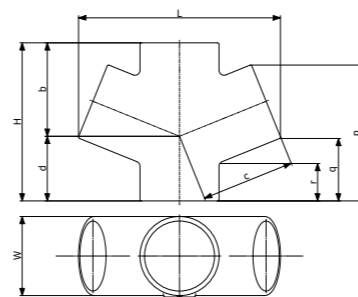

88° BRANCHES

DN	dn	L	H	W	b	c	d	p	q	r	Weight	Product code
	50	212	170	110	76	105	94	127	69	45	2.2	155825
100	75	220	190	110	90	110	100	145	62	40	2.7	179685
	100	243	230	110	105	120	115	179	69	49	3.7	155858
125	100	263	235	135	115	135	130	184	74	48	4.5	155874
150	100	294	245	160	115	145	130	190	80	52	5.9	155907

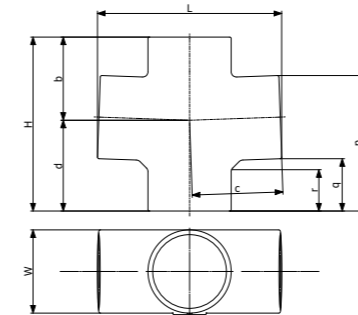

"All dimensions are in mm and nominal weights are in kg"

> Long tail double branches

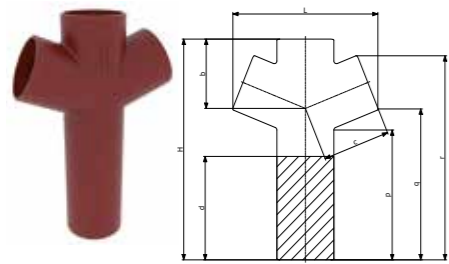

68° BRANCHES

DN	dn	L	H	W	b	c	d	p	q	r	Weight	Product code
100	100	280	414	110	130	130	284	244	281	383	6.3	176896

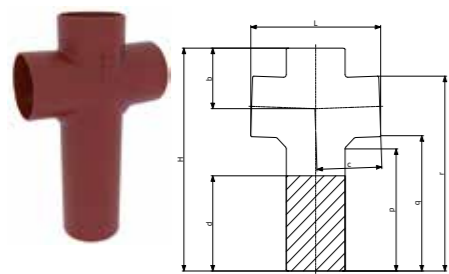
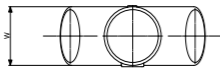

88° BRANCHES

DN	dn	L	H	W	b	c	d	p	q	r	Weight	Product code
100	100	243	405	110	110	120	295	222	244	354	5.9	176883

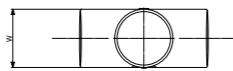

> Corner branches - Short corner branches



45° BRANCHES

DN	dn	L	H	W	b	c	d	p	q	r	Weight	Product code
100	100	227	260	227	190	190	70	242	166	46	5.2	156716

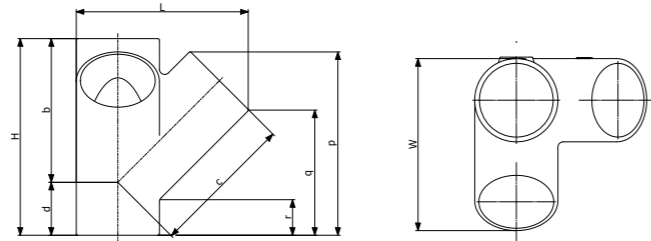

68° BRANCHES

DN	dn	L	H	W	b	c	d	p	q	r	Weight	Product code
75	75	158	180	158	110	110	70	149	72	36	2.1	156548
100	100	195	220	195	130	130	90	189	87	50	3.5	156714

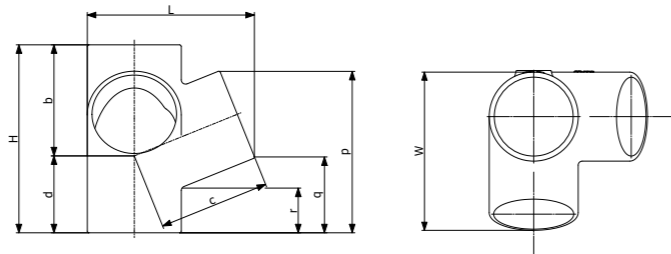

88° BRANCHES

DN	dn	L	H	W	b	c	d	p	q	r	Weight	Product code
75	75	137	180	136	85	95	95	140	57	36	2	179682
100	75	165	190	165	90	110	100	145	62	40	2.8	179683
	100	177	230	177	105	120	115	179	69	44	2.8	155860
125	100	199	235	199	110	130	125	184	74	48	4.3	155889
150	100	227	245	227	115	145	130	190	80	52	5.3	155919

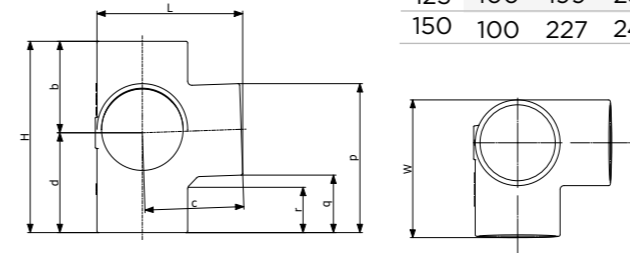

> Corner branches - Long tail corner branches



68° BRANCHES

DN	dn	L	H	W	b	c	d	p	q	r	Weight	Product code
100	100	195	414	195	130	130	284	383	244	281	5.1	176943

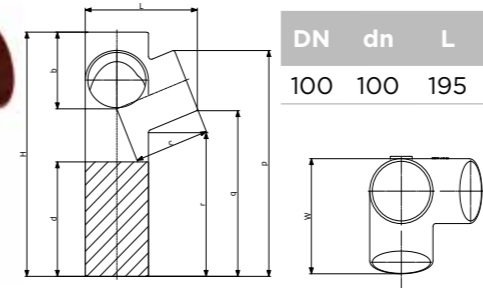

88° BRANCHES

DN	dn	L	H	W	b	c	d	p	q	r	Weight	Product code
100	100	177	430	177	105	115	325	379	244	269	5.3	155862

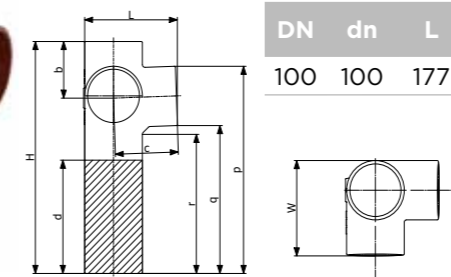

> BRANCHES | Single long arm branches



DN	dn	L	H	W	a	c	p	Weight	Product code
100	100	282	450	110	260	70	340	6	156726

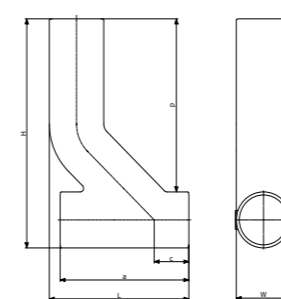

"All dimensions are in mm and nominal weights are in kg" - "Hatch patterned area in the drawings shows the max. cutting length".

"All dimensions are in mm and nominal weights are in kg" - "Hatch patterned area in the drawings shows the max. cutting length".

> TAPERED PIPES | Reducers

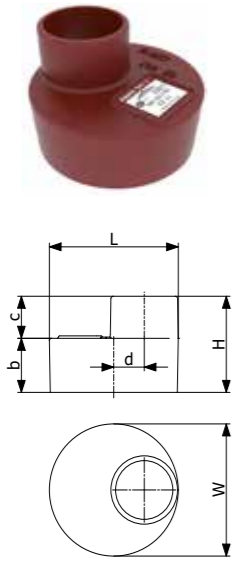

DN	dn	L	H	W	b	c	d	Weight	Product code
75	50	83	80	83	47	30	13	0.65	176727
100	50	110	80	110	45	30	26	0.9	155764
	75	110	90	110	45	35	14	1	176728
125	50	135	85	135	50	30	39	1.5	155765
	75	135	95	135	52	35	26	1.3	176730
150	100	135	95	135	50	40	13	1.6	155842
	50	160	95	160	55	30	51	1.9	155766
	75	160	100	160	57	35	39	1.9	176732
200	100	160	105	160	60	40	25	2	155843
	125	160	110	160	60	45	13	2	155892
	75	210	115	210	72	43	64	3.8	156532
250	100	210	115	210	70	40	50	3.6	155844
	125	210	120	210	70	45	38	3.8	155893
	150	210	125	210	65	50	25	3.4	155922
300	100	274	125	274	82	45	82	6	156690
	150	274	135	274	82	50	57	6.3	155923
	200	274	145	274	80	60	32	6.9	155942
400	100	326	140	326	95	45	108	9.4	156692
	150	326	150	326	97	50	83	11	155924
	200	326	160	326	95	60	58	10.2	155943
	250	326	170	326	95	70	26	10.7	155955
	300	429	200	429	100	100	52	19.6	157163

* For dimensions over DN 400 please contact us.

> ACCESS FITTINGS | Access pipes



ROUND DOOR

DN	L	H	W	ID	OD	Weight	Number of bolts	Product code
50	105	190	93	53	105	2.3	2	179191
75	134	220	115	78	134	3.2	2	179647
100	159	260	139	104	159	5	2	179192
125	202	280	202	152	202	7.0	3	280010
150	243	320	226	180	243	9.8	4	280012
200	243	360	277	180	243	12.9	4	280013
250	274	380	362	180	243	18.7	4	280014
300	326	400	413	180	243	25	4	280015

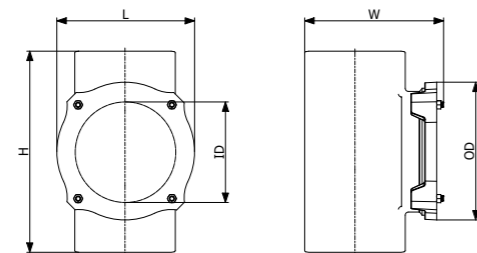

"All dimensions are in mm and nominal weights are in kg"

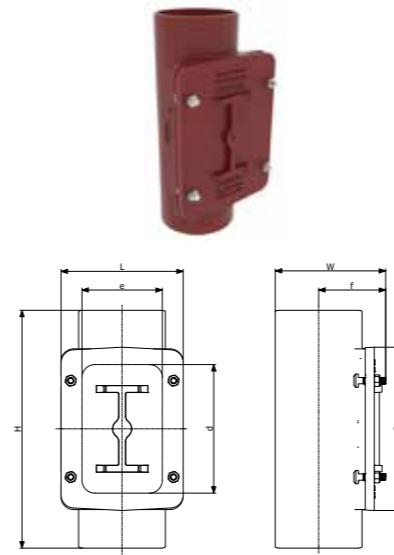

RECTANGULAR DOOR

DN	L	H	W	c	d	e	f	Weight	Product code
125	190	370	169	255	225	125	101	10.3	179197
150	215	395	192	280	250	150	112	14.3	179198
200	262	435	242	330	300	200	137	22	179199
250	330	540	307	380	350	260	170	38.5	179200
300	380	610	358	430	400	310	195	50	179201

> ACCESS FITTINGS | Blank ends

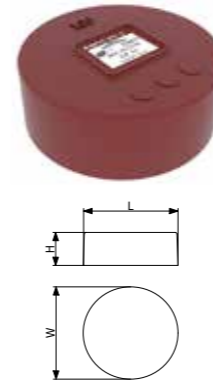

DN	L	H	W	Weight	Product code
50	58	30	58	0.25	155747
75	83	35	83	0.45	176700
100	110	40	110	0.8	155809
125	135	45	135	1.2	155865
150	160	50	160	1.7	155898
200	210	60	210	3.2	155928
250	274	70	274	5.9	155945
300	326	80	326	10	155957

> ACCESS FITTINGS | Expansion plugs

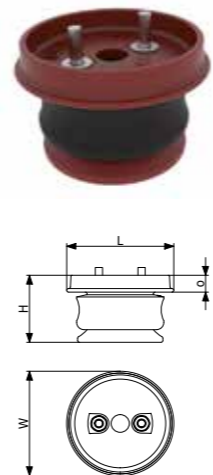

DN	L	H	W	o	Weight	Screw	Product code
50	62	47	62	14	0.22	M8x30	156374
75	90	71	90	20	0.6	M8x50	176715
100	118	77	118	23	1.2	M8x60	156579
125	143	77	143	24	1.7	M8x60	156747
150	168	73	168	22	2.4	M10x45	156839
200	220	87	220	26	5	M10x60	156961
250	284	100	284	44	6.2	M10x70	157060
300	336	100	336	44	9	M10x70	157125

See p.149 for information on resistance to accidental pressure. Expansion plugs with bleeding valve are available on request for DN 125/DN 150 and DN 200 (for watertightness tests).

"All dimensions are in mm and nominal weights are in kg"

> TRAPS & VENTILATION | Traps

BRANCH TRAPS DN < 200

DN	L	H	W	c	d	e	f	g	o	p	q	r	s	Access(*)	Weight	Product code
50	190	240	58	60	182	68	122	68	143	39	33	112	201	EP 50	2.5	156420
75	264	282	80	60	200	93	172	93	150	52	13	162	230	TS 50	4.6	176714
100	325	381	110	100	282	110	215	110	216	55	15	216	326	TS 50	7.9	156668
125	390	435	134	100	316	130	260	130	238	63	12	266	372	TS 75	10.7	156801
150	470	482	160	100	348	145	325	145	257	65	8	340	417	TS 125	16.9	156912

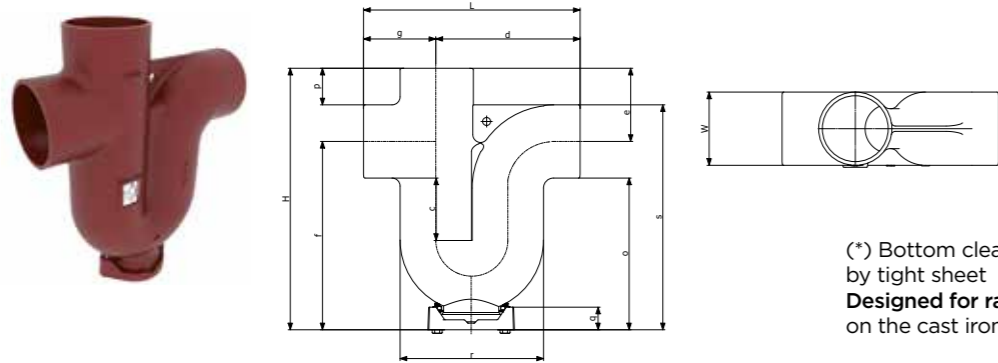

(*) Bottom cleaning access: EP by expansion plug / TS by tight sheet
Designed for rainwater networks. The arrows stamped on the cast iron body show the flow direction.

BRANCH TRAPS DN 200

DN	L	H	W	c	d	e	f	g	o	p	r	s	Weight	Product code
200	600	590	210	100	420	180	400	200	300	80	415	510	34.3	157018

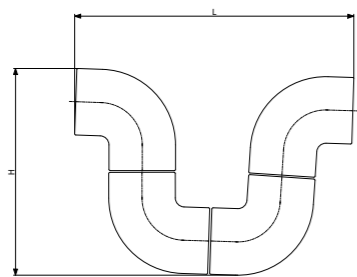
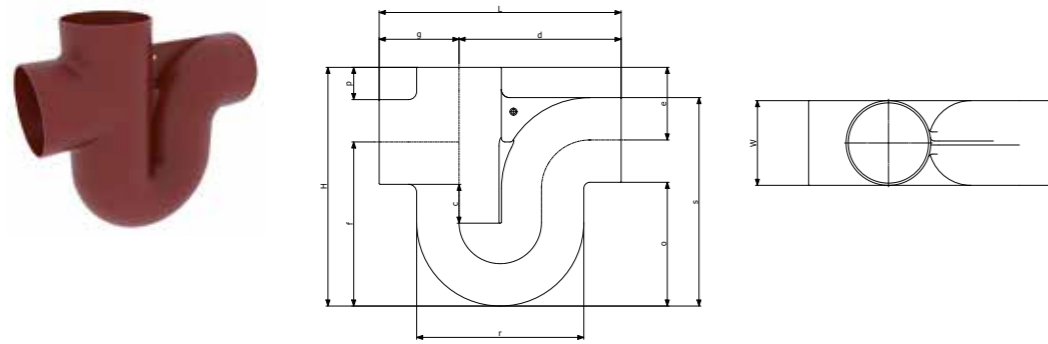

TRAPS DN ≥ 250: Installation with 88° bends

DN	L	H
250	900	725
300	1070	860

"All dimensions are in mm and nominal weights are in kg"

> TRAPS & VENTILATION | Traps

ANTI-SYPHON TRAPS with bottom access door DN 50

DN	L	H	W	c	d	Weight	Product code
50	165	255	58	80	187	2.5	229107

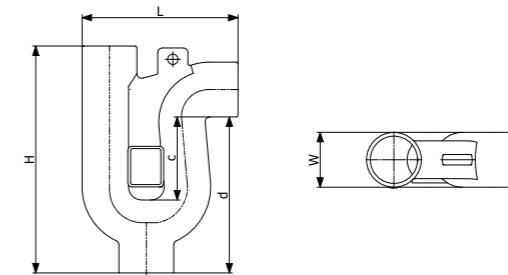

ANTI-SYPHON TRAPS with bottom access door DN 100-150

DN	L	H	W	b	c	Weight	Product code
100	316	382	110	316	350	9.2	179013
150	412	531	160	412	470	24.8	156916

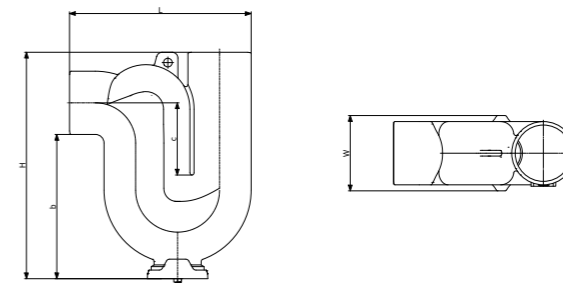

ANTI-SYPHON TRAPS with side access door*

DN	L	H	W	a	c	o	p	q	Weight	Product code
50	165	230	58	136	80	130	213	155	2.8	156422
75	240	300	83	199	80	131	272	189	4.8	156522

*With brass closing

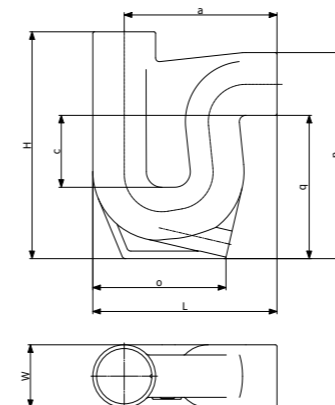

Suitable for all wastewater drainage systems, the Anti-Syphon Trap is particularly well-suited to systems without secondary ventilation. It ensures the retention of a water seal within the body of the trap to prevent odors traveling backwards through the system and fouling the atmosphere around sinks, washbasins, baths, rainwater outlets, etc. The Anti-Syphon Trap works by preventing the siphoning effect of a heavy discharge through the system. It does this through the internal partition within the trap allowing the air to bypass the water, thus breaking the vacuum created by the discharge water.

"All dimensions are in mm and nominal weights are in kg"

> TRAPS & VENTILATION | Traps

VENTED TRAPS

DN	Outlet	L	H	a	b	c	d	e	f	Weight
100	Vertical	575	371	163	236	229	342	228	-	8.81
100	Horizontal	399	371	163	236	108	342	228	283	6.55

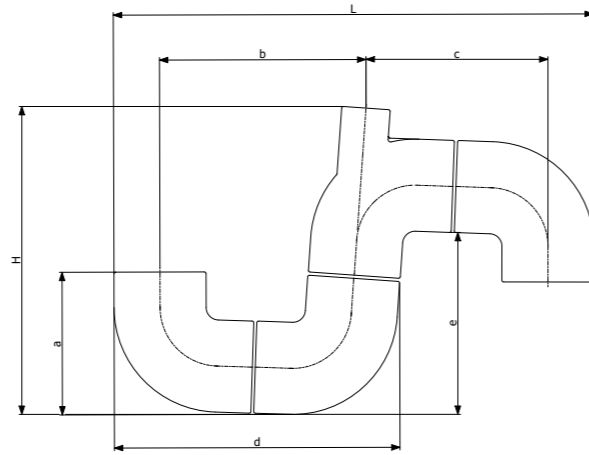

The vertical outlet version consists of 3 x product code: 155813 and 1 x product code 156585

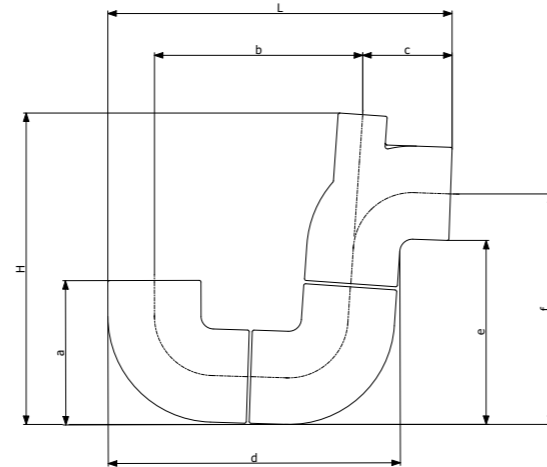

The horizontal outlet consists of 1 x product code: 156585 and 2 x product code: 155813

DN	Dn	Product code
100	-	155813
100	50	156585

"All dimensions are in mm and nominal weights are in kg"

> TRAPS & VENTILATION | Roof penetrators



DN	L	H	W	a	b	Weight	Product code
75	286	60	286	135	135	6.1	205922
100	324	60	324	158	246	6.6	205924
125	349	60	349	188	271	6.6	205925

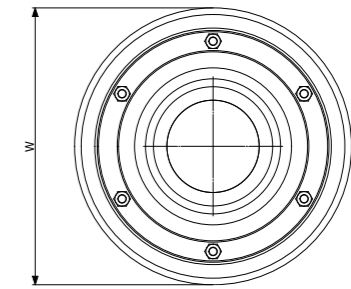
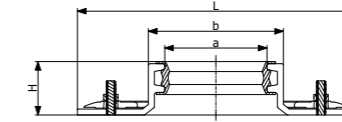

DN	Product code EPDM gasket	Weight	Product code NBR gasket	Weight
75	179894	0.2	179895	0.2
100	207320	0.3	207319	0.3
125	207335	0.3	207334	0.3

"All dimensions are in mm and nominal weights are in kg"

> STACK SUPPORT



DN	L	H	W	b	e	f	g	ø Ext	Weight	Product code
50	195	220	108	8	150	17	30	108	2.5	156413
75	218	220	133	8	175	19	30	133	3.1	156512
100	259	220	162	8	214	20	32	162	4.3	156657
125	275	220	187	8	228	20	32	197	5.4	156793
150	300	220	222	8	255	22	32	222	7.2	156904
200	362	220	278	8	310	22	36	278	10.5	157014
250	444	300	354	8	394	25	40	354	19.1	157097
300	498	300	406	8	448	30	40	406	26.5	157160
400	600	340	508	10	550	30	50	508	43.9	248776

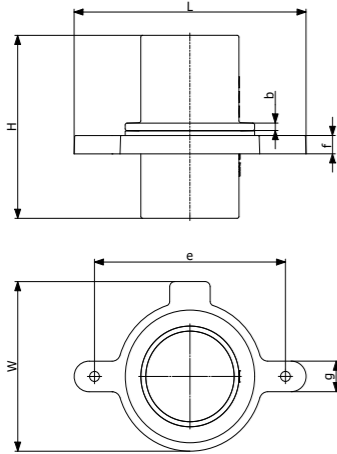

> STACK SUPPORT PIPE

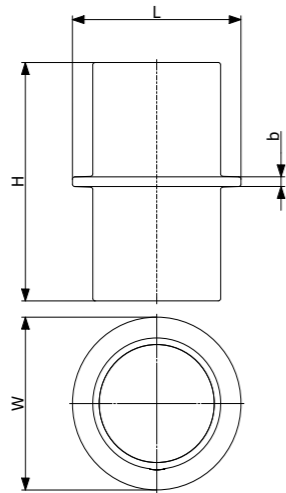

DN	L	H	W	b	Weight	Product code
50	87	220	87	8	1.3	156372
75	118	220	118	8	1.8	156462
100	145	220	145	8	2.4	156577
125	170	220	170	8	3.2	156745

"All dimensions are in mm and nominal weights are in kg"

> STACK SUPPORT BRACKET



DN	L	H	W	e	g	h	Weight	Product code
50	195	17	108	150	30	108	1	179217
75	218	19	133	175	30	133	1.2	176713
100	259	20	162	214	32	162	1.6	179219
125	275	20	187	228	32	187	1.7	179220

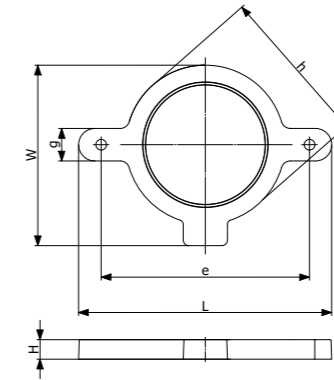

> SPECIAL FITTINGS | Manifold connector



DN	L	H	W	a	d	e	Weight	Product code
100	204	125	200	43	142	62	3.2	175626
150	265	165	290	70	184	81	6.1	175629

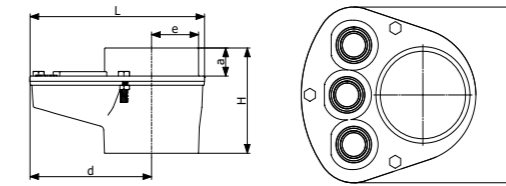

The multi-waste manifold simplifies waste plumbing by grouping all associated pipework from various sources such as sinks, basins, bidets, urinals and showers to one internal point above the finished floor level. See p.169 for installation details.

"All dimensions are in mm and nominal weights are in kg"

> SPECIAL FITTINGS | Multi-waste manifold

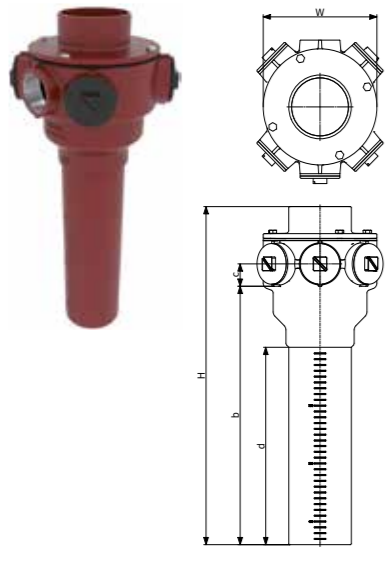

Low level waste connections

DN	L	H	W	b	d	f	g	h	i	j	k	Weight	Product code
100	445	582	445	445	340	45	174	22	165	120	110	12.8	261138
150	445	591	445	445	345	55	181	25	220	170	160	17.3	261434

> SPECIAL FITTINGS | Single Stack Branch



Branches for single downpipe with 2 to 3 inlets - combined networks

DN	Lateral adjustments	L	H	W	o	p	q	Weight	Product code
100	3 consecutive DN 100 at 90°	280	490	230	392	140	282	11	177237
	2 DN 100 at 90°	230	490	230	392	140	282	10.4	177236
	2 DN 100 at 180°	280	490	180	392	140	282	10.8	177235

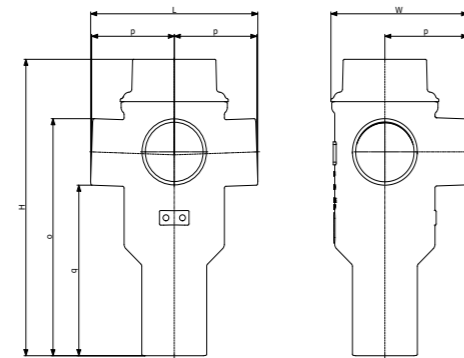

"All dimensions are in mm and nominal weights are in kg"

> SPECIAL FITTINGS | Compensators of movement

Conditions of use: Fittings intended to absorb the relative movement between two components of pipework; each one of its ends is fixed to 2 different structure elements.

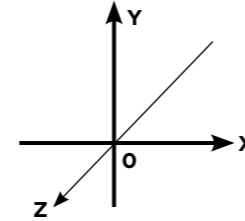

L is the dimension of the compensator in neutral position.
The maximum authorised movements along the three axes are noted:

- X axial movement
- Y vertical radial movement
- Z horizontal radial movement

Every reference is composed of:

- one movement absorber
- two bi-directional stack support pipes

Acceptable pressure for DN 75 to 200:

- negative pressures up to - 0.9 bar
- positive pressures up to 3 bar (accidental and internal hydrostatic pressure)



FOR SHORT RANGES OF MOVEMENTS

DN	OD	L	H	W	q	r	Socket extension			Weight	Product code
							X	Y	Z		
75	83	895	218	83	81	139	±30	±30	±30	18.4	155050
100	110	897	259	110	80	140	±30	±30	±30	20.8	172638
125	135	897	275	135	80	140	±30	±30	±30	26	155067
150	160	909	300	160	78	142	±30	±30	±30	29.3	155072
200	210	932	362	210	78	142	±30	±30	±30	40.4	155077
250	274	1143	444	274	115	185	±30	±30	±30	83	185458

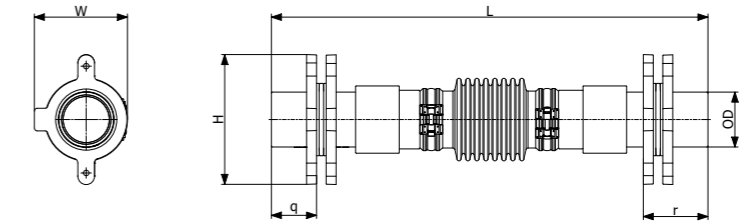

FOR LONG RANGES OF MOVEMENTS

DN	OD	L	H	W	q	r	Socket extension			Weight	Product code
							X	Y	Z		
75	83	1794	218	83	81	139	±60	±130	±130	25.6	155051
100	110	1796	259	110	80	140	±60	±130	±130	27.5	155063
125	135	1796	275	135	80	140	±60	±130	±130	33	155068
150	160	1802	300	160	78	142	±60	±130	±130	39.8	155073
200	210	1824	362	210	78	142	±60	±130	±130	55.6	155078

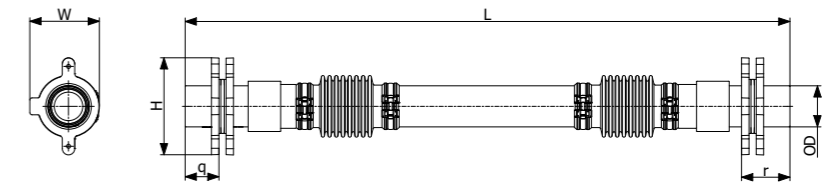

"All dimensions are in mm and nominal weights are in kg"

PAM-GLOBAL® Plus - PIPES



DN	L	H	W	Weight	Product code
50	3000	58	58	12.9	155302
75	3000	83	83	18.8	176787
100	3000	110	110	25.1	155348
125	3000	135	135	35.3	155391
150	3000	160	160	42.1	155413
200	3000	210	210	69.1	155447
250	3000	274	274	99.5	155475
300	3000	326	326	129.4	155492
400	3000	429	429	179.5	155508
	2800	429	429	167.5	224507

* For dimensions over DN 400 please contact us.



PAM-GLOBAL® Plus - FITTINGS

> BENDS | Short radius bends

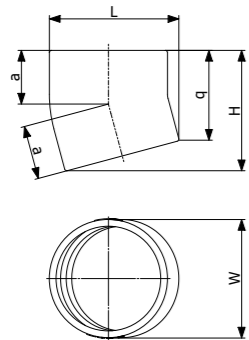

15° BENDS

DN	L	H	W	a	q	Weight	Product code
50	66	80	58	40	66	0.4	155202
75	93	99	83	45	78	0.68	176781
100	121	112	110	50	83	1	155237
125	148	134	135	60	99	1.7	155262
150	173	148	160	65	108	2.5	155278
200	227	184	210	80	129	4.6	173774
400	455	284	429	100	181	21.4	on request

"All dimensions are in mm and nominal weights are in kg"

> BENDS | Short radius bends

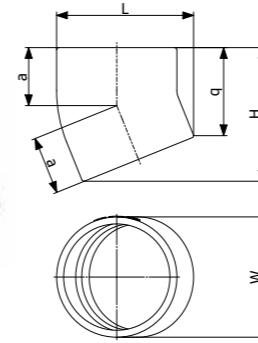

22° BENDS

DN	L	H	W	a	q	Weight	Product code
50	70	88	58	40	66	0.45	155308
75	97	105	83	47	74	0.8	155327
100	126	125	110	54	84	1.3	155358
125	152	143	135	61	92	1.9	155396
150	179	162	160	69	102	2.6	155421
200	233	200	210	83	122	4.4	155455
250	300	240	274	100	138	9.5	155482
300	356	279	326	115	157	15.3	155499
400	466	324	429	142	177	23.7	on request

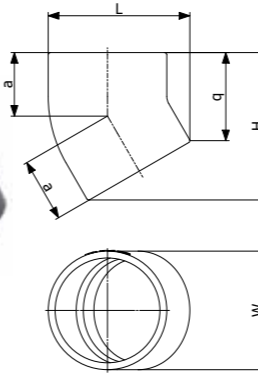

30° BENDS

DN	L	H	W	a	q	Weight	Product code
50	76	97	58	45	69	0.5	155203
75	102	114	83	50	73	0.8	176782
100	132	136	110	60	81	1.3	155238
125	160	164	135	70	96	2	155263
150	189	188	160	80	108	3	155279
200	243	229	210	95	124	5.4	179335

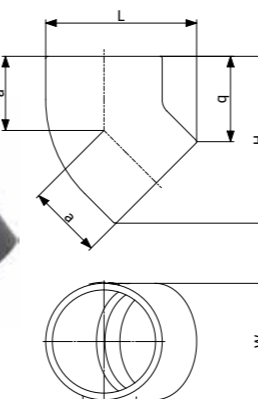

45° BENDS

DN	L	H	W	a	q	Weight	Product code
50	84	106	58	50	65	0.6	155201
75	112	132	83	60	73	0.9	176735
100	142	158	110	70	80	1.6	155236
125	171	184	135	80	89	2.1	155261
150	199	210	160	90	97	3.2	155277
200	256	262	210	110	113	5.3	155289
250	324	319	274	130	125	10	155481
300	387	380	326	155	149	18.3	155498
400	540	573	429	247	270	34.4	155509

* For dimensions over DN 400 please contact us.

"All dimensions are in mm and nominal weights are in kg"

> BENDS | Short radius bends

68° BENDS

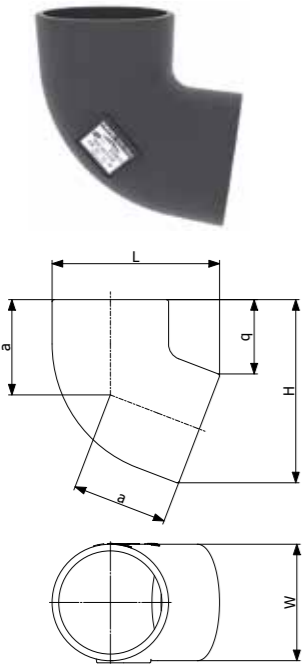

DN	L	H	W	a	q	Weight	Product code
50	104	123	58	65	70	0.8	155200
75	131	149	83	80	72	1	176736
100	159	176	110	90	74	1.8	155235
125	188	205	135	105	80	3	155260
150	219	237	160	120	89	4.1	155276
200	277	295	210	145	99	7.8	155452

88° BENDS

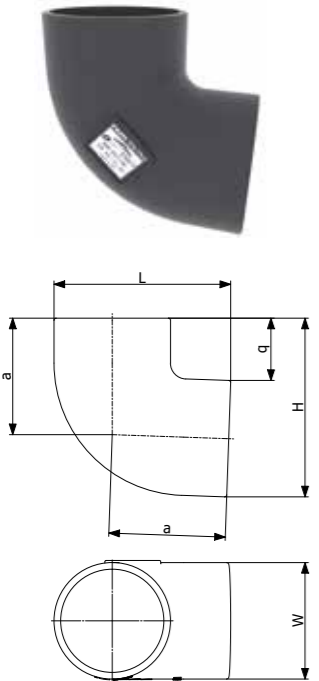

DN	L	H	W	a	q	Weight	Product code
50	104	107	58	75	49	0.8	155199
75	138	140	83	95	57	1.4	176737
100	166	169	110	110	59	2.2	155234
125	194	197	135	125	62	2.9	155259
150	227	230	160	145	70	4.3	155275
200	288	291	210	180	81	8.1	155451
250	360	363	274	223	89	13.5	155479
300	427	431	326	280	105	27.7	155496
400	644	651	429	466	223	59	on request

> BENDS | 88° Double bends



DN	L	H	W	a	b	c	o	Weight	Product code
50	148	148	58	121	50	100	148	1	235800
75	183	183	83	145	60	120	183	1.5	235801
100	228	228	110	170	70	140	228	2.8	155359
150	303	303	160	219	90	180	303	6.3	155422

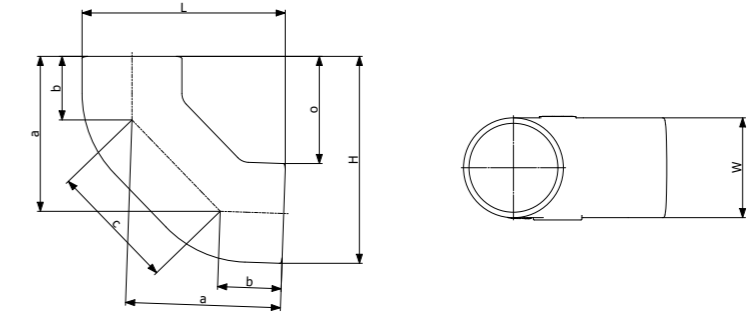

> BRANCHES | Single branches

45° BRANCHES



DN	dn	L	H	W	b	c	o	p	q	r	Weight	Product code
50	50	144	185	58	135	135	50	165	124	36	1.35	155213
75	50	156	180	83	135	135	45	161	120	43	1.6	176740
	75	179	215	83	155	155	60	198	140	40	2.2	176742
100	50	191	200	110	165	165	35	172	131	47	2.4	155245
	75	214	235	110	170	170	50	209	151	46	3.2	176743
125	100	238	275	110	205	205	70	253	175	45	4	155255
	50	218	205	135	185	185	20	170	130	44	3.2	155264
	75	237	240	135	195	200	45	215	156	51	4.2	176784
150	100	261	280	135	220	220	60	254	177	47	5	155267
	125	284	320	135	240	240	80	296	201	49	5.2	155271
	75	265	255	160	210	220	35	220	161	54	5.1	176785
200	100	287	295	160	240	240	55	262	185	54	5.8	155281
	125	307	325	160	255	255	70	298	202	52	7.4	155282
	150	323	355	160	265	265	90	333	219	53	7.9	155285
250	100	340	310	210	265	265	40	275	198	67	9.3	155291
	125	360	340	210	280	280	55	310	215	64	11.6	155292
	150	383	375	210	300	300	75	353	240	66	12.3	155293
300	200	418	455	210	340	340	115	428	280	68	17.1	155295
	150	440	405	274	350	350	55	358	245	75	22	208730
	250	486	480	274	390	390	90	440	291	75	22.4	155483
400	250	537	580	274	430	430	130	530	335	70	29	155490
	250	588	580	326	465	465	115	540	347	80	37.6	155500
	300	634	660	326	505	505	155	661	431	115	46.3	155507
400	300	728	660	429	555	555	105	620	389	86	56.4	155510
	400	820	835	429	645	645	190	795	492	101	98	on request

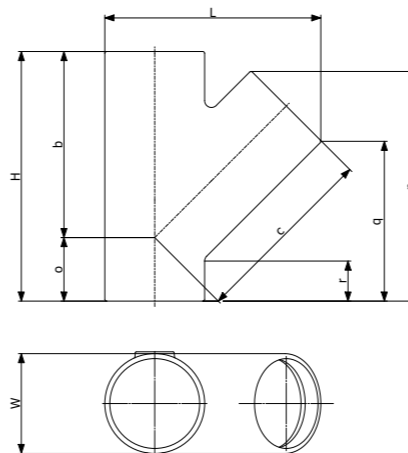

*For dimensions over DN 400 please contact us.

"All dimensions are in mm and nominal weights are in kg"

"All dimensions are in mm and nominal weights are in kg" - "Hatch patterned area in the drawings shows the max. cutting length".

> BRANCHES | Single branches

68° BRANCHES

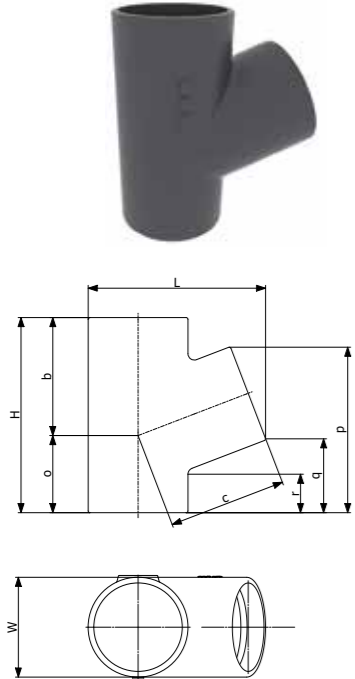

DN	dn	L	H	W	b	c	o	p	q	r	Weight	Product code
50	50	118	145	58	80	80	55	117	65	37	1	155315
75	50	140	155	83	95	95	60	122	69	42	1.4	155330
	75	158	180	83	110	110	70	149	72	37	2	155343
100	50	168	155	110	100	110	55	123	69	43	2	155364
	75	186	185	110	115	125	70	155	79	44	2.6	155367
125	100	195	220	110	130	130	85	189	87	50	2.8	155379
	125	222	225	135	140	145	85	190	88	50	3.9	155399
150	125	235	255	135	155	155	100	220	95	50	4.5	155408
	150	243	235	160	150	155	85	194	92	55	4.8	155429
200	125	262	265	160	165	170	100	226	101	56	5.7	155431
	150	276	295	160	180	180	115	256	108	55	6.5	155441
250	150	329	310	210	200	210	110	263	114	62	8.5	155460
	200	352	365	210	225	225	140	321	126	63	12	155469
300	250	452	460	274	285	285	170	408	154	77	21.1	155489
300	300	544	545	326	345	345	170	430	178	80	33.4	155506

88° BRANCHES

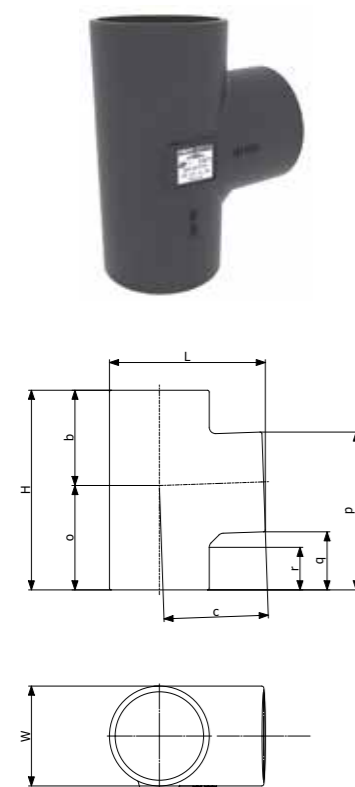

DN	dn	L	H	W	b	c	o	p	q	r	Weight	Product code
50	50	110	145	58	66	80	79	111	53	31	1	155212
75	50	132	160	83	75	90	85	117	59	42	1.5	176744
	75	138	180	83	85	95	95	140	57	37	1.6	176745
100	50	161	170	110	76	105	94	127	69	45	2	155244
	75	166	190	110	90	110	100	145	62	40	2.4	155746
125	100	172	220	110	105	115	115	174	64	41	2.8	155253
	100	199	235	135	110	130	125	184	74	48	4.2	173022
150	125	205	260	135	123	135	137	209	74	48	5	155407
	100	227	245	160	115	145	130	190	80	52	5.6	155428
200	150	237	300	160	142	155	158	243	83	55	6.7	155440
200	200	388	365	210	172	183	193	296	86	67	11	155468
250	250	366	455	274	228	243	240	375	101	77	19.5	155488
300	300	434	530	326	265	265	265	437	111	87	35	155505
400	400	616	684	429	314	370	370	595	165	90	67	on request

"All dimensions are in mm and nominal weights are in kg"

> BRANCHES | Long tail single branches

45° BRANCHES



DN	dn	L	H	W	b	c	d	e	p	q	r	Weight	Product code
100	100	238	430	110	205	205	225	170	424	346	241	5.3	155381
150	150	323	705	110	265	265	440	350	684	571	403	18.3	155443
200	200	423	770	110	340	346	430	320	749	600	383	26	155471

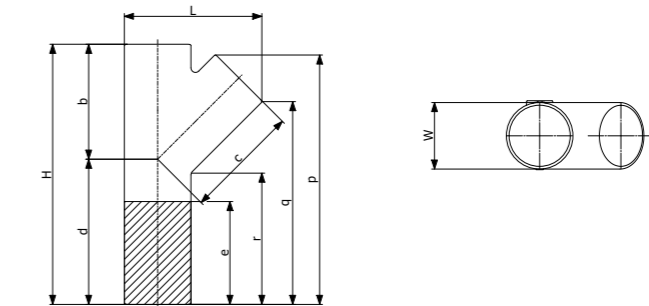

68° BRANCHES



DN	dn	L	H	W	b	c	d	e	p	q	r	Weight	Product code
100	100	195	460	110	130	130	330	250	430	328	290	4.8	155388

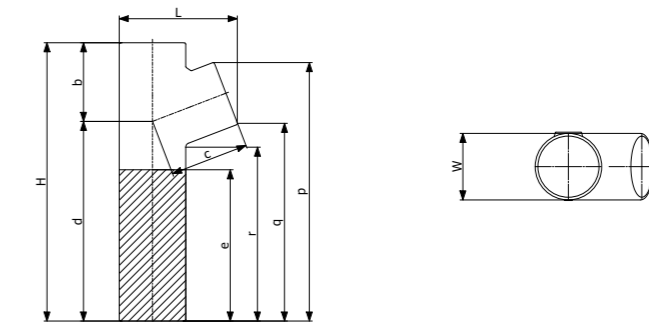

"All dimensions are in mm and nominal weights are in kg" - "Hatch patterned area in the drawings shows the max. cutting length".

> BRANCHES | Double branches

> Short double branches



45° BRANCHES

DN	dn	L	H	W	b	c	d	p	q	r	Weight	Product code
100	100	346	260	110	190	190	70	243	165	46	5.3	155384
125	125	421	305	135	240	240	65	285	190	45	7.9	155411
150	150	488	355	160	265	265	90	334	277	55	11.8	155445
200	200	627	455	210	340	340	115	428	280	67	18.4	155473

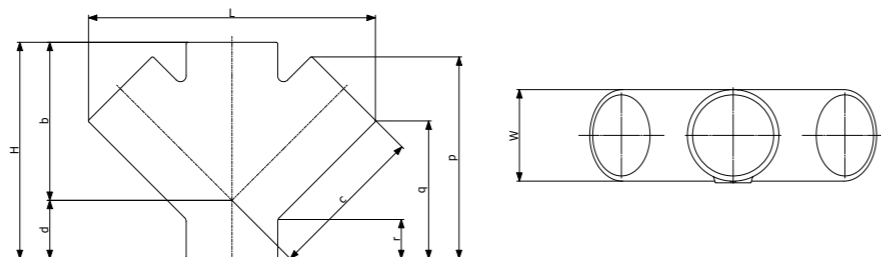

> BRANCHES | Double branches

> Corner branches - Short corner branches



45° BRANCHES

DN	dn	L	H	W	b	c	d	p	q	r	Weight	Product code
100	100	227	260	227	190	190	70	242	166	46	5.2	155387

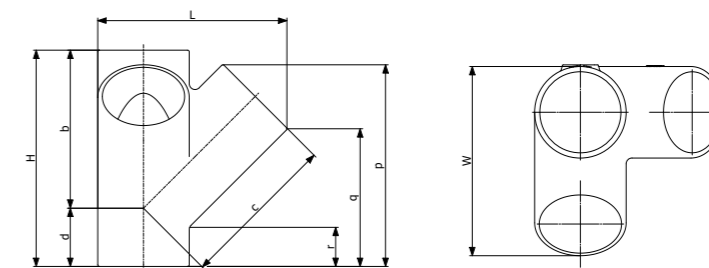

68° BRANCHES

DN	dn	L	H	W	b	c	d	p	q	r	Weight	Product code
50	50	178	145	58	85	85	60	118	64	35	1.2	155317
75	75	234	180	83	110	110	70	149	72	36	2.3	155345
100	75	262	185	110	115	125	70	155	79	44	3	155362
	100	281	220	110	130	130	85	189	87	50	3.4	155383
125	100	309	225	135	140	145	85	190	88	50	4.4	155397
	125	336	255	135	155	155	100	220	95	51	5.5	155410
150	125	364	265	160	165	170	100	226	101	56	6.6	155426
	150	392	295	160	180	180	115	256	108	57	8.2	155444
200	150	448	310	210	200	210	110	259	110	58	10.7	155456
	200	494	365	210	225	225	140	321	126	67	14	155472

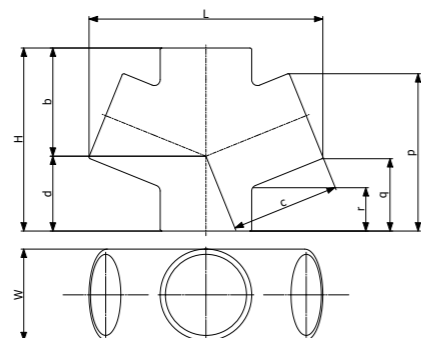

68° BRANCHES

DN	dn	L	H	W	b	c	d	p	q	r	Weight	Product code
75	75	158	180	158	110	110	70	149	72	36	2.1	155346
100	100	195	220	195	130	130	90	189	87	50	3.5	155386

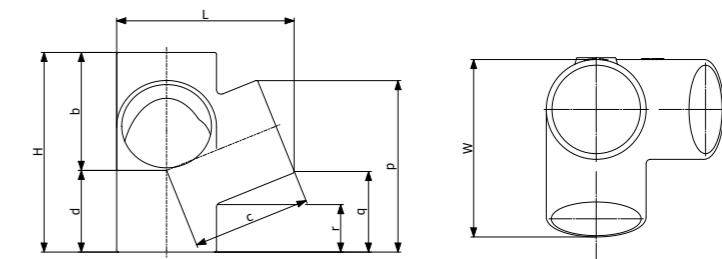

"All dimensions are in mm and nominal weights are in kg"

"All dimensions are in mm and nominal weights are in kg"

> **BRANCHES** | Single long arm branches



DN	dn	L	H	W	a	c	p	Weight	Product code
100	100	282	450	110	260	70	340	6	155389

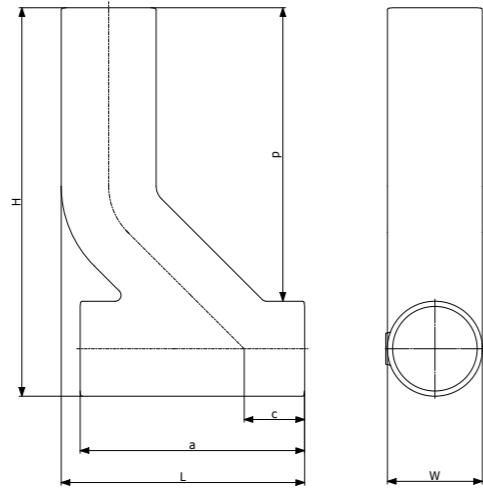

> **ACCESS FITTINGS** | Access pipes

> Round door



DN	L	H	W	b	c	d	Weight	Product code
50	105	190	93	64	53	105	2.3	179348
75	134	220	115	73	78	134	3.2	179648
100	159	260	139	84	104	159	5	179350

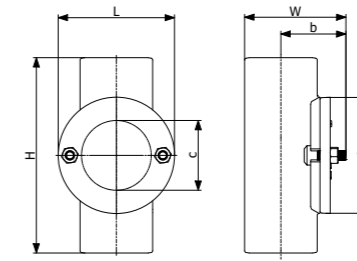

> **TAPERED PIPES** | Reducers



DN	dn	L	H	W	b	c	d	Weight	Product code
75	50	83	80	83	47	30	13	0.65	176747
100	50	110	80	110	45	30	26	0.9	155209
	75	110	90	110	45	35	14	1	176748
125	50	135	85	135	50	30	39	1.5	155210
	75	135	95	135	52	35	26	1.3	176749
150	100	135	95	135	50	40	13	1.6	155250
	50	160	95	160	55	30	51	1.9	155211
	75	160	100	160	57	35	39	1.9	176750
200	100	160	105	160	60	40	25	2	155251
	125	160	110	160	60	45	13	2	155269
	75	210	115	210	72	43	64	3.8	155340
250	100	210	115	210	70	40	50	3.6	155252
	125	210	120	210	70	45	38	3.8	155270
	150	210	125	210	65	50	25	3.4	155284
300	100	274	125	274	82	43	82	6	155377
	150	274	135	274	82	50	57	6.3	155437
	200	274	145	274	80	60	32	6.9	155465
400	150	326	150	326	97	50	83	11	155438
	200	326	160	326	95	60	58	10.2	155466
	250	326	170	326	95	70	26	10.7	155487
	300	429	200	429	100	100	52	19.6	155504

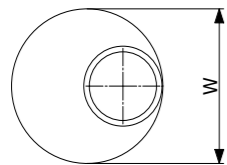
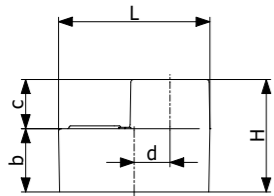

*For dimensions over DN 400 please contact us.

> **ACCESS FITTINGS** | Access pipes

> Rectangular door



DN	L	H	W	c	d	e	f	Weight	Product code
125	190	370	169	255	225	125	101	10.3	179352
150	215	395	192	280	250	150	112	14.5	179353
200	262	435	242	330	330	200	137	22	179354

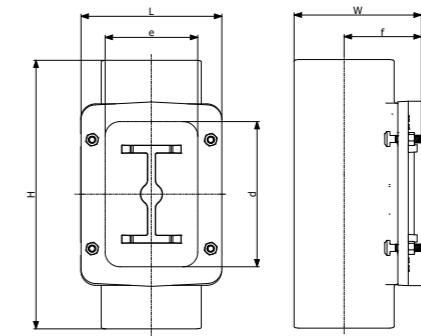

"All dimensions are in mm and nominal weights are in kg"

"All dimensions are in mm and nominal weights are in kg"

> ACCESS FITTINGS | Blank ends

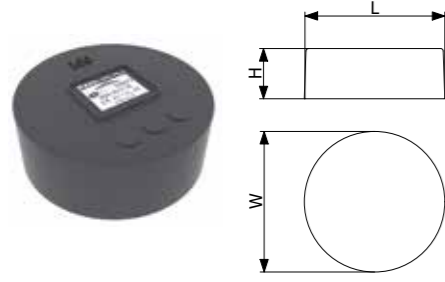

DN	L	H	W	Weight	Product code
50	58	30	58	0.25	155197
75	83	35	83	0.45	176783
100	110	40	110	0.8	155231
125	135	45	135	1.2	155257
150	160	50	160	1.7	155273
200	210	60	210	3.2	155287
250	274	70	274	5.9	155477
300	326	80	326	10	155494

> ACCESS FITTINGS | Expansion plugs

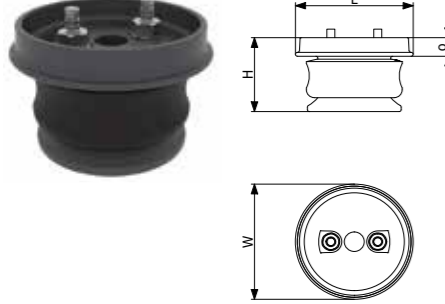

DN	L	H	W	o	Weight	Screw	Product code
50	62	47	62	14	0.22	M8x30	155303
75	90	71	90	20	0.6	M8x50	155322
100	118	77	118	23	1.2	M8x60	155351
125	143	77	143	24	1.7	M8x60	155392
150	168	73	168	22	2.4	M10x45	155417
200	220	87	220	26	5	M10x60	155450
250	284	100	284	44	6.2	M10x70	155478
300	336	100	336	44	9	M10x70	155495

See p.149 for information on resistance to accidental pressure.
Expansion plugs with bleeding valve are available on request for DN 125/DN 150 and DN 200 (for watertightness test).

> TRAPS | Branch traps

BRANCH TRAP DN < 200

DN	L	H	W	c	d	e	f	g	o	p	q	r	s	Access(*)	Weight	Product code
50	190	240	58	60	182	68	122	68	143	39	33	112	201	EP 50	2.5	155311
75	264	282	80	60	200	93	172	93	150	52	13	162	230	TS 50	4.6	176739
100	325	381	110	100	282	110	215	110	216	55	15	216	326	TS 50	7.9	155372
125	390	435	134	100	316	130	260	130	238	63	12	266	372	TS 75	10.7	155404
150	470	482	160	100	348	145	325	145	257	65	8	340	417	TS 125	16.9	155436

(*) with bottom cleaning access:
EP by expansion plug / TS by tight sheet
Designed for rainwater networks. The arrows stamped on the cast iron body show the flow direction.

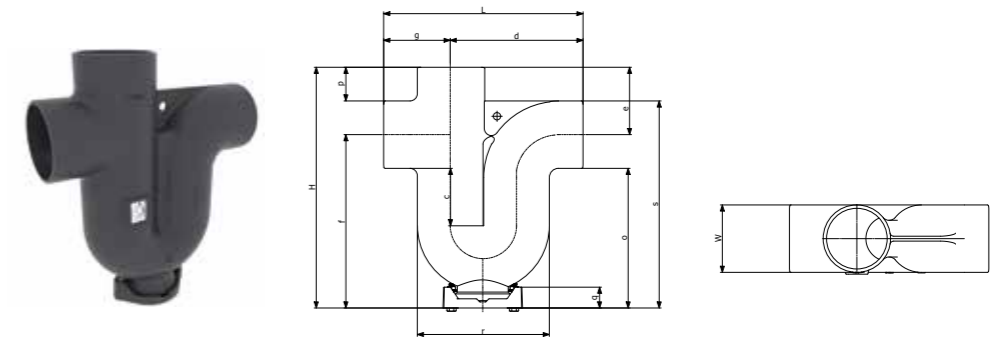

BRANCH TRAP DN 200

DN	L	H	W	c	d	e	f	g	o	p	r	s	Weight	Product code
200	600	590	210	100	420	180	400	200	300	80	415	510	34.3	155464

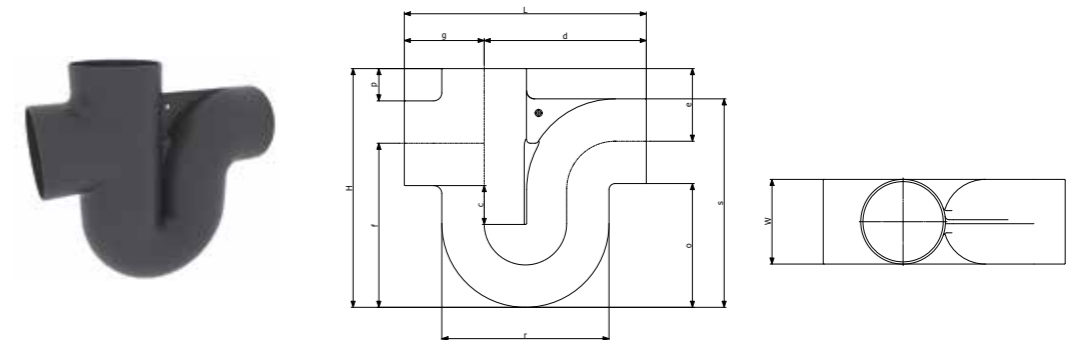

Designed for rainwater networks when subjected to aggressive environments.

> STACK SUPPORT

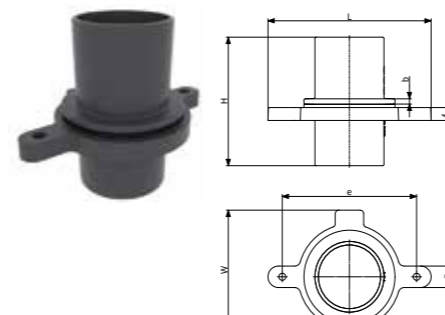

DN	L	H	W	b	e	f	g	o Ext	Weight	Product code
50	195	220	108	8	150	17	30	108	2.5	212273
75	218	220	133	8	175	19	30	133	3.1	211041
100	259	220	162	8	214	20	32	162	4.3	171912
125	275	220	187	8	228	20	32	197	5.4	211042
150	300	220	222	8	255	22	32	222	7.2	171914
300	498	300	406	8	448	30	40	406	26.5	208264
400	600	340	508	10	550	30	50	508	43.9	on request

"All dimensions are in mm and nominal weights are in kg"

"All dimensions are in mm and nominal weights are in kg"

SMU Zn - PIPES



DN	L	H	W	Weight	Product code
50	3000	58	58	12.9	241706
75/80	3000	83	83	18.8	241708
100	3000	110	110	25.1	241709
125	3000	135	135	35.3	253994
150	3000	160	160	42.1	241710
200	3000	210	210	69.1	253915
250	3000	274	274	99.5	253916
300	3000	326	326	129.4	253917
400	3000	429	429	179.5	260554
	2800	429	429	167.5	261111

* For dimensions over DN 400 please contact us.

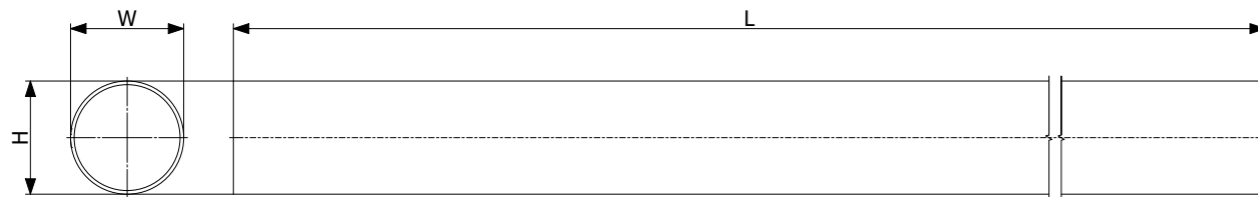

RECENT PROJECTS IN ASIA WITH SMU Zn

- 1 - Shangri-La Island Hotel - Hong Kong
- 2 - Shaw Auditorium HKUST - Hong Kong
- 3 - Studio City Phase 2 - Macau
- 4 - 11 SKIES Commercial Complex - Hong Kong
- 5 - HKIA Terminal 2 extensions - Hong Kong
- 6 - Kai Tak Sports Ground - Hong Kong
- 7 - Orsted O&M Taichung Facilities - Taiwan
- 8 - The Avenue Monterey Place - Hong Kong
- 9 - AMC Tsueng Kwan O - Hong Kong



SMU Zn - FITTINGS

For details of the fittings to be used with SMU Zn pipes, please contact us.

"All dimensions are in mm and nominal weights are in kg"

All our Residential (Type R) downpipes and fittings are delivered with their couplings (see p.126)

GRAVITY SYSTEMS - PIPES

> ROUND DOWNPIPES | Straight

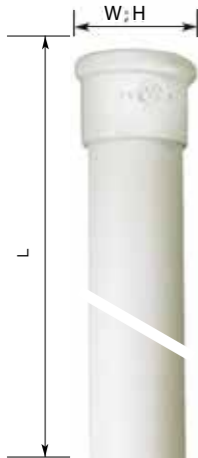

DN	L	H	W	Weight	Product code
75	1 m	107	107	6.9	155536
	2 m	107	107	12.9	155539
100	1 m	134	134	9.2	155595
	2 m	134	134	17.2	155599
125	1 m	162	162	12.9	155662
	2 m	162	162	24.2	155666

> ROUND DOWNPIPES | Bended

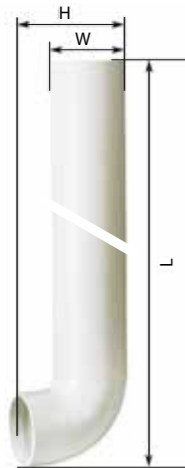

DN	L	H	W	Weight	Product code
75	1 m	154	107	7.6	155572
	2 m	154	107	13.6	155574
100	1 m	177	134	10.1	155640
	2 m	177	134	18.1	155643
125	1 m	206	162	14.2	155700
	2 m	206	162	25.5	155702

> ROUND DOWNPIPES WITH SUPPORT LUG | Straight*

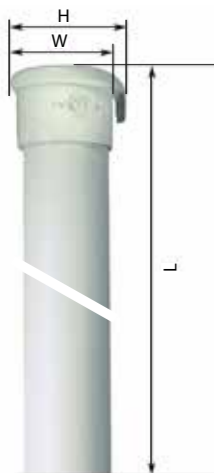

DN	L	H	W	Weight	Product code
75	1 m	119	107	6.9	155535
	2 m	119	107	12.9	155538
100	1 m	147	134	9.2	155594
	2 m	147	134	17.2	155598
125	1 m	173	162	12.9	155661
	2 m	173	162	24.2	155665

* Delivered with wall fixing bracket (see p.126)

"All dimensions are in mm and nominal weights are in kg"

> ROUND DOWNPIPES WITH SUPPORT LUG | Bended*

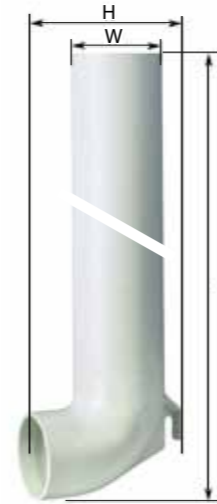

DN	L	H	W	Weight	Product code
75	1 m	165	107	6.9	155571
	2 m	165	107	12.9	155573
100	1 m	188	134	12.9	155639
	2 m	188	134	17.2	155642
125	1 m	216	162	10.1	155699
	2 m	216	162	24.2	155701

* Delivered with wall fixing bracket (see p.126)

> ROUND FLUTED DOWNPIPES | Straight*



DN	L	H	W	Weight	Product code
75	1 m	130	121	9.8	155534
	2 m	130	121	16.9	155537
100	1 m	158	150	13.5	155592
	2 m	158	150	23.2	155596
125	1 m	184	175	16.7	155659
	2 m	184	175	29.1	155663

* Delivered with wall fixing bracket (see p.126)

> ROUND FLUTED DOWNPIPES | Fishes head shoe*



DN	L	H	W	Weight	Product code
75	1 m	203	121	14.3	155577
	2 m	203	121	21.4	155578
100	1 m	268	150	19.5	155648
	2 m	268	150	29.2	155649
125	1 m	325	175	23.7	155705
	2 m	325	175	36.1	155706

* Delivered with wall fixing bracket (see p.126)

"All dimensions are in mm and nominal weights are in kg"

GRAVITY SYSTEMS - FITTINGS

> BENDS | Round downpipe bends



45° BEND WITH SOCKET

DN	L	H	W	Weight	Product code
75	162	210	116	2.2	155557
100	186	226	145	3.2	155622
125	215	250	173	4.6	155684



68° BEND WITH SOCKET

DN	L	H	W	Weight	Product code
75	148	122	115	2	155555*
100	210	185	144	3.5	155619
125	242	198	173	5.1	155681

*Availability: Contact us

> BENDS | Round fluted downpipe bends

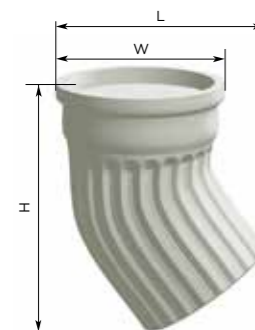

45° BEND WITH SOCKET

DN	L	H	W	Weight	Product code
100	164	231	144	3	155620



68° BEND WITH SOCKET

DN	L	H	W	Weight	Product code
100	210	236	144	3.5	155617

"All dimensions are in mm and nominal weights are in kg"

> OFFSETS | Round offsets



OFFSET WITH SOCKET / E = 75

DN	L	H	W	Weight	Product code
100	202	311	144	4.3	155630
125	229	343	173	6.4	155692



OFFSET WITH SOCKET / E = 150

DN	L	H	W	Weight	Product code
75	249	311	115	3.1	155561*
100	277	317	144	4.1	155626
125	304	348	173	5.7	155688

*Availability: Contact us

> OFFSETS | Fluted offsets

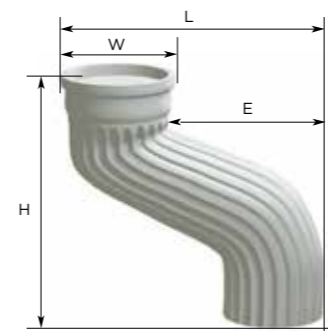

OFFSET WITH SOCKET / E = 150

DN	L	H	W	Weight	Product code
100	277	316	144	4.8	155625

"All dimensions are in mm and nominal weights are in kg"

> DECORATIVE RAINWATER HEAD



DN	L	H	W	Weight	Product code
75	385	260	260	3.3	156510
100	385	260	274	4.7	156656
125	385	260	289	6.1	156792

> ROUND / FLUTED CONNECTOR



DN	L	H	W	Weight	Product code
75	121	110	121	1.25	155584*
100	150	115	150	1.9	155654
125	175	120	175	2.4	155710

* Availability: Contact us

> ACCESSORIES | Wall fixing bracket*



Weight	Product code
0.12	155531

* A wall fixing bracket is delivered with each downpipe with support lug

> ACCESSORIES | Couplings



COUPLINGS FOR DOWNPIPES AND SHOES

DN	Weight	Product code
75	0.03	155566
100	0.04	155632
125	0.05	155694



COUPLINGS FOR BENDS AND OFFSETS

DN	Weight	Product code
75	0.07	156077
100	0.09	156133
125	0.11	156187

"All dimensions are in mm and nominal weights are in kg"

> GARGOYLE | For roadsides (Profile A)



DN	Entitled	L	H	W	Weight	Product code
75	Shoe	196	57	140	18.5	157373
100	Shoe	196	57	140	24.7	157377
100	Head	150	65	162	21	157379

> GARGOYLE | For pavements (Profile T)



DN	Entitled	L	H	W	Weight	Product code
75	Shoe	191	110	140	1.25	157374
100	Shoe	191	110	140	2.4	157378
100	Head	162	130	162	1.9	157382

> GARGOYLE | Shoe to head connector



Dimension	Entitled	Weight	Product code
DN 75	SMU Plus pipe	3.7	155320
DN 100	SMU Plus pipe	7.7	155347
120 X 40	Rectangular pipe	5.5	157385

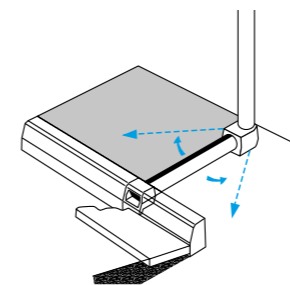

"All dimensions are in mm and nominal weights are in kg"

EPAMS® - OUTLETS

> OUTLETS TO BE WELDED



- > Stainless steel body, including M10 bolts
- > Aluminum grating

DN	DE (mm)	Capacity l/s	Surface drainage (m ²)	Weight (kg)	Product code
50	58	13	260	5.4	171283
75	83	23	460	5.7	171284
100	110	26	520	6.4	171285
125*	135	26*	520	8.3	172850

*This outlet is the basis for the next three outlets, on which various elements are grafted depending on the application field. See p.173 for main dimensions.

> OUTLETS WITH FLANGE



- > Stainless steel body, including M10 bolts
- > Aluminum grating
- > Aluminum flange

DN	DE (mm)	Capacity l/s	Surface drainage (m ²)	Weight (kg)	Product code
50	58	13	260	6.2	171288
75	83	23	460	6.5	171289
100	110	26	520	7.2	171290
125*	135	26*	520	9.1	172871

> OUTLETS WITH STEEL PLATE



- > Stainless steel body, including M10 bolts
- > Aluminum grating
- > Stainless steel plate - 500 x 500 mm

DN	DE (mm)	Capacity l/s	Surface drainage (m ²)	Weight (kg)	Product code
50	58	13	260	6.4	171081
75	83	23	460	6.7	171267
100	110	26	520	7.4	171305
125*	135	26*	520	9.3	172874

* The advantage of the DN 125 outlet is in the "gutters" application where the water cover height can exceed 55 mm (see French Technical Approval 14+5/01-656 - § 2.21)

> OUTLETS FOR FLEXIBLE PVC MEMBRANES



- > Stainless steel body, including M10 bolts
- > Aluminum grating
- > Laminate-steel PVC plate - 500 x 500 mm

DN	DE (mm)	Capacity l/s	Surface drainage (m ²)	Weight (kg)	Product code
50	58	13	260	6.8	171286
75	83	23	460	7.1	171287
100	110	26	520	7.7	171263
125*	135	26*	520	9.6	172876

EPAMS - ACCESSORIES

> ELEVATING KITS



- > Anti-vortex device fitted to Elevating Kit.
- > For roofs with waterproofing protection by fine gravel or by flags on isolating layer by fine gravel.

Description	Height (mm)	Product code
Elevating device + anti-vortex	90	171291
Elevating device + anti-vortex	250	171292

> ANCHORING STEEL PLATE

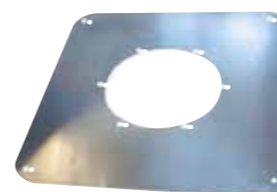

Description	Product code
Anchoring steel plate	172431

> NUTS & SCREWS

NUTS & SCREWS

Description	Weight (kg)	Product code
Valid for all DN	0.01	171295

* The advantage of the DN 125 outlet is in the "gutters" application where the water cover height can exceed 55 mm (see French Technical Approval 14+5/01-656 - § 2.21)

ITINERO® - PIPES



DN	L	H	W	Weight	Product code
100	3000	110	110	25.1	277898
125	3000	135	135	35.3	277845
150	3000	160	160	42.1	277862
200	3000	210	210	69.1	277863
250	3000	274	274	99.5	277864
300	3000	326	326	129.4	277865
400	3000	429	429	179.5	277866
500	3000	532	532	247.6	277846
600	3000	635	635	325.5	277847

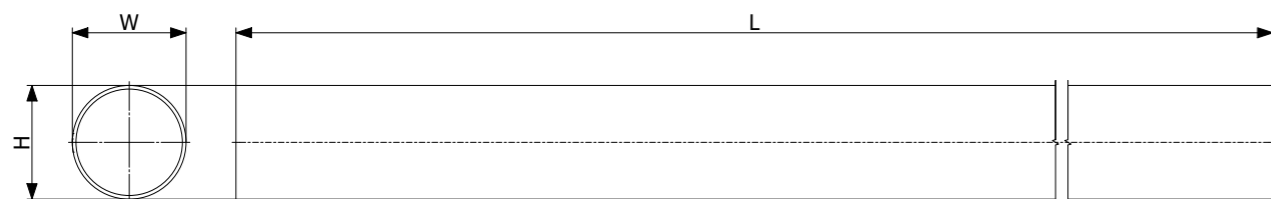

ITINERO® - FITTINGS

> BENDS | Short radius bends

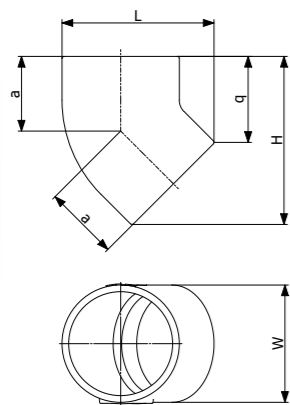

45° BENDS

DN	L	H	W	a	q	Weight	Product code
100	142	158	110	70	80	1.6	277899
125	171	184	135	80	89	2.1	277827
150	199	210	160	90	97	3.2	277867
200	256	262	210	110	113	5.3	277868
250	324	319	274	130	125	10	277869
300	387	380	326	155	149	18.3	277870
400	540	573	429	247	270	34.4	277871
500	730	678	532	318	350	52	277861
600	788	821	635	350	370	111	277852

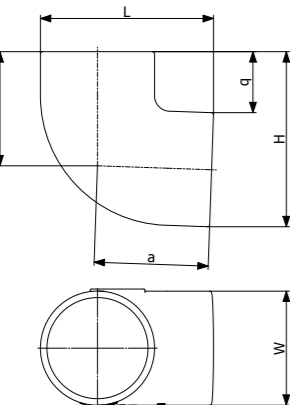

88° BENDS

DN	L	H	W	a	q	Weight	Product code
100	166	169	110	110	59	2.2	277905
125	194	197	135	125	62	2.9	277826
150	227	230	160	145	70	4.3	277879
200	288	291	210	180	81	8.1	277880
250	360	363	274	223	89	13.5	277881
300	427	431	326	280	105	27.7	277882
400	644	651	429	466	223	59	277896

"All dimensions are in mm and nominal weights are in kg"

> BRANCHES | Single branches

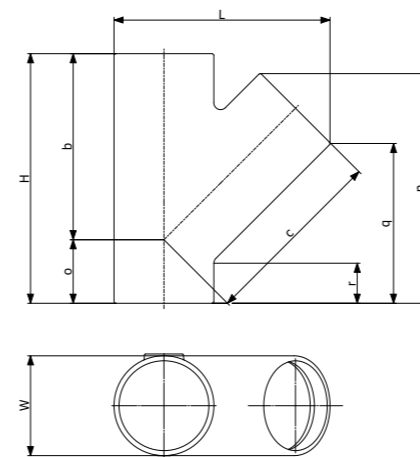

45° BRANCHES

DN	dn	L	H	W	b	c	o	p	q	r	Weight	Product code
100	100	238	275	110	205	205	70	253	175	45	4	277824
125	100	261	280	135	220	220	60	254	177	47	5	277830
	125	284	320	135	240	240	80	296	201	49	5.2	277832
150	100	287	295	160	240	240	55	262	185	54	5.8	277835
	125	307	325	160	255	255	70	298	202	52	7.4	277836
150	150	323	355	160	265	265	90	333	219	53	7.9	277837
	100	340	310	210	265	265	40	275	198	67	9.3	277838
200	125	360	340	210	280	280	55	310	215	64	11.6	277839
	150	383	375	210	300	300	75	353	240	66	12.3	277883
200	200	418	455	210	340	340	115	428	280	68	17.1	277884
	100	398	330	274	315	315	15	276	198	72	13.6	277914
250	125	420	370	274	335	335	35	318	223	75	17.8	277911
	150	440	405	274	350	350	55	358	245	75	22	277885
200	200	486	480	274	390	390	90	440	291	75	22.4	277886
	250	537	580	274	430	430	130	530	335	70	29	277887
300	100	445	350	326	345	345	5	287	208	88	18.9	277915
	125	464	360	326	360	360	15	316	221	80	22.7	277909
150	150	487	415	326	380	380	35	359	246	81	28	277913
	200	547	485	326	415	440	70	454	305	81	31	277908
250	250	588	580	326	465	465	115	540	347	80	37.6	277888
	300	634	660	326	505	505	155	661	431	115	46.3	277889
400	300	728	660	429	555	555	105	620	389	86	56.4	277890
500	300	861	720	532	635	680	85	680	448	114	86	277907
600	300	965	725	635	687	751	38	683	452	115	100	277850



88° BRANCHES

DN	dn	L	H	W	b	c	o	p	q	r	Weight	Product code
300	300	434	530	326	265	265	265	437	111	87	35	278355
400	300	590	650	429	297	370	353	529	203	121	58	278356

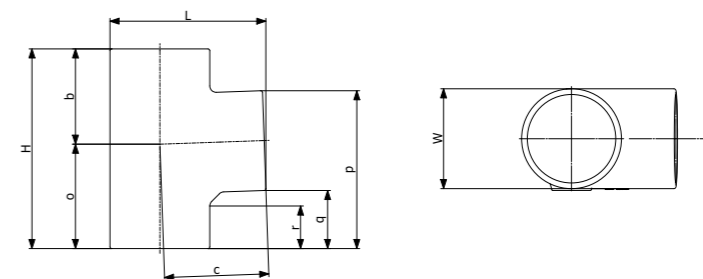

"All dimensions are in mm and nominal weights are in kg"

> TAPERED PIPES | Reducers

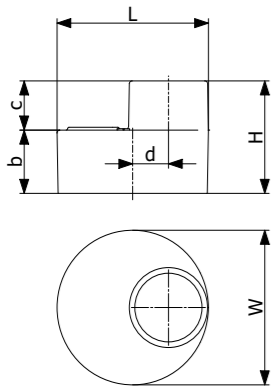

DN	dn	L	H	W	b	c	d	Weight	Product code
125	100	135	95	135	50	40	13	1.6	277822
150	100	160	105	160	60	40	25	2	277900
	125	160	110	160	60	45	13	2	277872
200	100	210	115	210	70	40	50	3.6	277823
	125	210	120	210	70	45	38	3.8	277831
250	150	210	125	210	65	50	25	3.4	277873
	150	274	135	274	82	50	57	6.3	277874
300	200	274	145	274	80	60	32	6.9	277875
	150	326	150	326	97	50	83	11	277876
400	200	326	160	326	95	60	58	10.2	277877
	250	326	170	326	95	70	26	10.7	277840
500	300	429	200	429	100	100	52	19.6	277878
500	400	532	200	532	100	100	52	28.9	277860

> ACCESS FITTINGS | Access pipes

> Rectangular door



DN	L	H	W	c	d	e	f	Weight	Product code
100	160	340	138	230	200	100	83	7.6	277857
125	190	370	169	255	225	125	101	10.3	277858
150	215	395	192	280	250	150	112	14.5	277859
200	262	435	242	330	300	200	137	22	277916
250	330	540	307	380	350	260	170	38.5	277917
300	380	610	358	430	400	310	195	50	277918

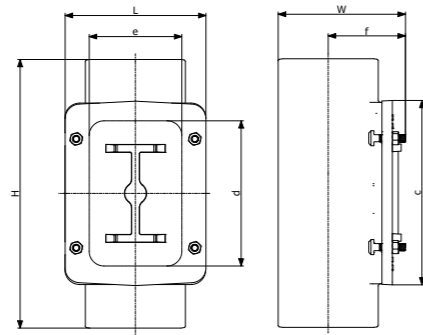

"All dimensions are in mm and nominal weights are in kg"

> ACCESS FITTINGS | Blank ends



DN	L	H	W	Weight	Product code
100	110	40	110	0.8	277819
125	135	45	135	1.2	277825
150	160	50	160	1.7	277901
200	210	60	210	3.2	277902
250	274	70	274	5.9	277903
300	326	80	326	10	277904
400	429	98	429	21	277895



> STACK SUPPORT



DN	L	H	W	b	e	f	g	∅Ext	Weight	Product code
100	259	220	162	8	214	20	32	162	4.3	277906
150	300	220	222	8	255	22	32	222	7.2	277891
200	362	220	278	8	310	22	36	278	10.5	277892
250	444	300	354	8	394	25	40	354	19.1	277893
300	498	300	406	8	448	30	40	406	26.5	277894
400	600	340	508	10	550	30	50	508	43.9	277897

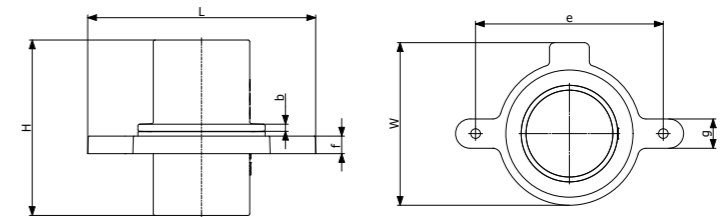

"All dimensions are in mm and nominal weights are in kg"

STANDARD COUPLINGS

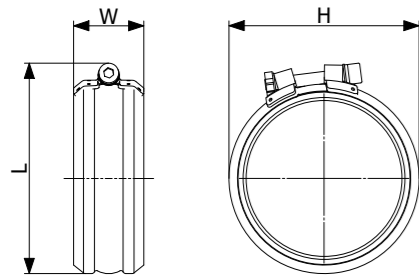

PAM RAPID-S / PAM RAPID INOX

DN	L	H	W	Weight	PAM RAPID-S	PAM RAPID INOX
					W2	W5
50	70	80	42	0.1	210424	185635
75	90	103	42	0.12	210426	207819
100	125	139	48	0.18	210427	185636
125	147	161	56	0.28	210428	207820
150	172	187	56	0.32	210429	207831
200	223	240	70	0.6	210430	185637
250	290	315	95	1.1	228759	228773
300	350	375	95	1.25	228771	228775

The PAM Rapid is designed for full tightening with "zero gap", there is no need to check the torque. For DN 250 and 300, apply the following torque: 25 N.m.

Standard version W2

technical specifications:

- > Strap, clamps: 1.4510 /11 (AISI 430Ti / 439)

All stainless steel version W5

technical specifications:

- > Strap, clamps: 1.4404 / 1.4571 (AISI 316 L/316Ti)
- > Screw and nut: austenitic stainless steel A4-70 or AISI 316

PAM RAPID WITH NBR GASKET (Nitrile coupling)

DN	L	H	W	Weight	PAM RAPID NBR GASKET
					W5
50	70	80	42	0.1	212705
75	90	103	42	0.12	212708
100	125	139	48	0.18	212709
125	147	161	56	0.28	212710
150	172	187	56	0.32	212711
200	223	240	70	0.6	212712
250	290	315	95	1.1	212713
300	350	375	95	1.25	212714

For wastewater liable to contain hot oil, solvents or hydrocarbons, it is recommended to use couplings equipped with specific NBR gaskets.

"All dimensions are in mm and nominal weights are in kg"

STANDARD COUPLINGS



PAM R ("R" FOR REPAIR)

DN	L	H	W	Weight	Product code
50	67	86	50	0.18	233899
75	91	110	50	0.2	233900
100	118	137	58	0.29	233901
125	147	166	58	0.31	233902
150	167	186	58	0.36	233903
200	223	242	58	0.47	233904

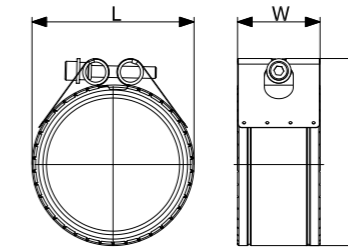

All stainless steel

- > Strap: austenitic stainless steel - 1.4404/1.4571 (AISI 316L/316Ti)
- > Barrels: austenitic stainless steel -1.4404/1.4571 (AISI 316/316L/316Ti)
- > Screw: stainless steel A4-70, with anti-seizing coating. (thrust collar: AISI 316/316L)
- > Sealing gasket: EPDM

"All dimensions are in mm and nominal weights are in kg"

HIGH PRESSURE COUPLINGS

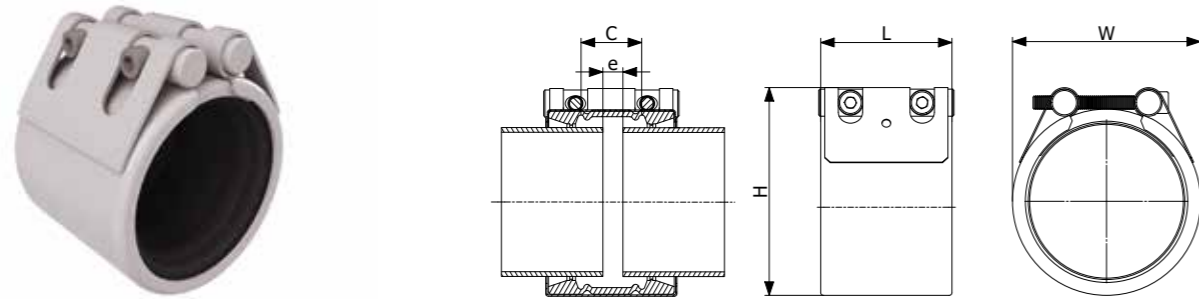

PAM HP FLEX-S (W4)

DN	L	H	W	c	e	Pressure Resistance bar	Torque Nm	Screw	Weight	Product code	
										EPDM	NBR
100	89	150	133	42	5	10	25	M8	1.6	278442	278451
125	114	177	155	67	5	10	25	M10	2.3	278443	278452
150	114	202	181	67	5	10	25	M10	2.5	278444	278453
200	114	252	242	67	5	10	25	M10	3.2	278445	278454
250	114	316	295	67	5	10	25	M10	3.5	278446	278455
300	144	414	352	81	5	10	40	M10	9.5	278447	278456
400	144	516	458	81	5	10	80	M10	9	278448	278457
500	144	619	561	81	5	6	80	M10	11	278449	278458
600	144	721	663	81	5	6	80	M10	13	278450	278459

Type W4
 Casing: 1.4301 / AISI 304
 Screws: 1.4404 / AISI 316L
 Barrels: 1.4401/ AISI 316
 Strengthening plate: 1.4301 / AISI 304
 Sealing gasket: EPDM or NBR

PAM HP FLEX-INOX (W5)

DN	L	H	W	c	e	Pressure Resistance bar	Torque Nm	Screw	Weight	Product code	
										EPDM	NBR
100	89	150	133	42	5	10	25	M8	1.6	278478	278487
125	114	177	155	67	5	10	25	M10	2.3	278479	278488
150	114	202	181	67	5	10	25	M10	2.5	278480	278489
200	114	252	242	67	5	10	25	M10	3.2	278481	278490
250	114	316	295	67	5	10	25	M10	3.5	278482	278491
300	144	414	352	81	5	10	40	M10	9.5	278483	278492
400	144	516	458	81	5	10	80	M10	9	278484	278493
500	144	619	561	81	5	6	80	M10	11	278485	278494
600	144	721	663	81	5	6	80	M10	13	278486	278495

Type W5
 Casing: 1.4404 / AISI 316L
 Screws: 1.4404 / AISI 316L
 Barrels: 1.4401/ AISI 316
 Strengthening plate: 1.4404 / AISI 316L
 Sealing gasket: EPDM or NBR

"All dimensions are in mm and nominal weights are in kg"

GRIPPED HIGH PRESSURE COUPLINGS

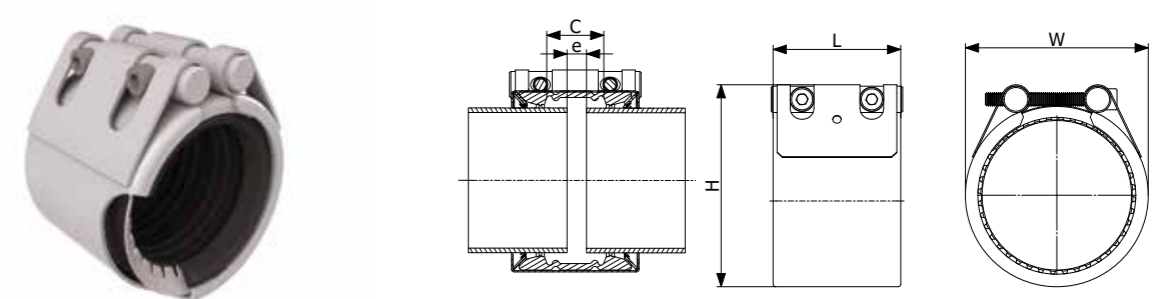

PAM HP GRIP-S (W4)

DN	L	H	W	c	e	Pressure Resistance bar	Torque Nm	Screw	Weight	Product code	
										EPDM	NBR
100	89	156	139	16	8	10	25	M10	1.4	278460	278469
125	114	192	166	24	8	10	60	M12	2.6	278461	278470
150	114	218	191	24	8	10	85	M16	3.2	278462	278471
200	114	269	241	24	8	10	60	M16	5.0	278463	278472
250	114	357	304	24	8	10	80	M16	8.6	278464	278473
300	114	410	357	24	8	10	80	M16	10.0	278465	278474

Type W4
 Casing: 1.4301 / AISI 304
 Screws: 1.4404 / AISI 316L
 Barrels: 1.4401/ AISI 316
 Strengthening plate: 1.4301 / AISI 304
 Sealing gasket: EPDM or NBR
 Grips: 1.4310 / AISI 301

PAM HP GRIP-INOX (W5)

DN	L	H	W	c	e	Pressure Resistance bar	Torque Nm	Screw	Weight	Product code	
										EPDM	NBR
100	89	156	139	16	8	10	25	M10	1.4	278496	278505
125	114	192	166	24	8	10	60	M12	2.6	278497	278506
150	114	218	191	24	8	10	85	M16	3.2	278498	278507
200	114	269	241	24	8	10	60	M16	5.0	278499	278508
250	114	357	304	24	8	10	80	M16	8.6	278500	278509
300	114	410	357	24	8	10	80	M16	10.0	278501	278510
400	142	499	473	63	10	10	160	M16	10.3	269446	-
500	146	603	575	63	10	6	160	M16	16.9	269447	-
600	146	711	683	63	10	6	160	M16	19.6	269448	-

Type W5
 Casing: 1.4404 / AISI 316L
 Screws: 1.4404 / AISI 316L
 Barrels: 1.4401/ AISI 316
 Strengthening plate: 1.4404 / AISI 316L
 Sealing gasket: EPDM or NBR
 Grips: 1.4310 / AISI 301

"All dimensions are in mm and nominal weights are in kg"

GRIP COLLARS

GRIP COLLARS FOR COUPLINGS

Totally versatile, the PAM grip collar is compatible with all the PAM designed couplings or those of equivalent shape.

DN	L	H	W	a	b	c	Wrench dimension	Weight	Product code
50	132	76	88	88	22	72	6	0.45	221261
75	155	78	105	105	25	73	6	0.53	221268
100	211	93	145	145	33	88	6	0.9	220750
125	229	93	165	165	32	88	6	1	221269
150	260	102	196	196	32	96	6	1.2	221270
200	316	118	252	252	32	115	8	1.7	221271
250	394	140	318	318	38	131	8	2.3	227039
300	447	140	371	371	38	131	8	2.5	227040

Pressure resistance
 DN 50-125: 10 bar
 DN 150-200: 5 bar
 DN 250-300: 3 bar

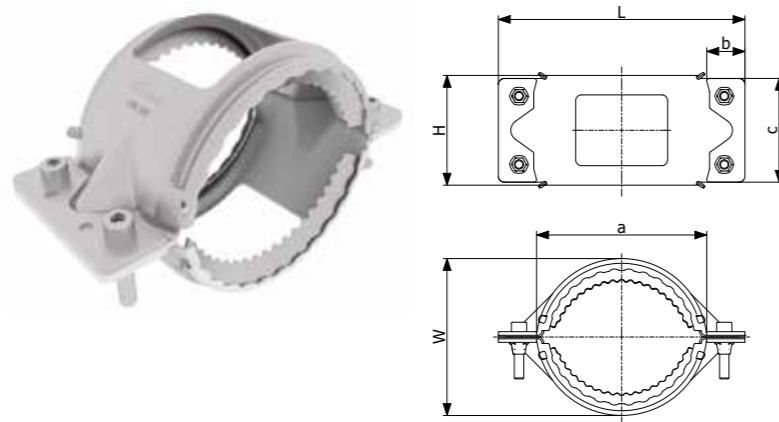

GRIP COLLARS FOR EXPANSION PLUGS

DN	L	H	W	a	b	c	Wrench dimension	Weight	Product code
50	132	47	88	88	22	43	6	0.33	222092
75	155	47	105	105	25	41	6	0.4	222127
100	211	50	145	145	33	45	6	0.6	221563
125	229	54	165	165	32	49	6	0.7	222129
150	260	56	196	196	32	51	6	0.9	222131
200	316	64	252	252	32	60	8	1.2	222133

Pressure resistance
 DN 50-125: 10 bar
 DN 150-200: 5 bar

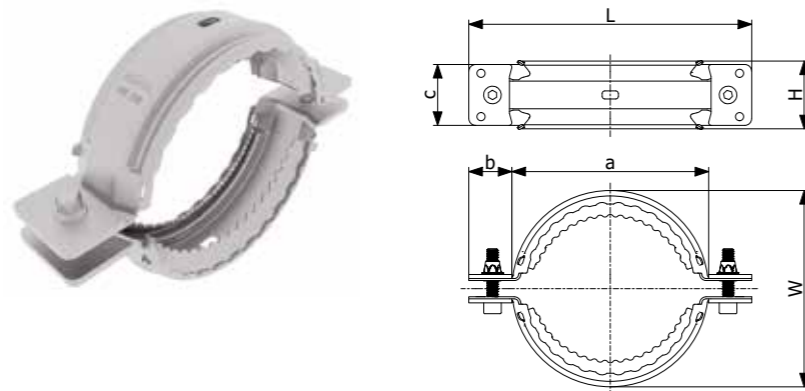

"All dimensions are in mm and nominal weights are in kg"

CONNECTORS

For connection to other materials refer to the table on p.166.



STEPPING RINGS

DN	DE*	Weight	Materials	Product code
50	50	0.02	HDPE and PVC	156399
75	63	0.06	HDPE	156495
75	77	0.03	PVC	156494
100	91	0.1	HDPE	156555
100	100	0.05	PVC	156635
125	125	0.06	HDPE and PVC	156778
200	200	0.15	HDPE and PVC	157000
250	250	0.45	HDPE and PVC	157085

* External diameters of other materials

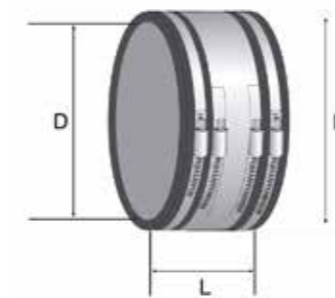

ADAPTING COLLARS

DN	D min.*	D max.*	L	Weight	Product code
75	75	90	100	0.4	255300
100	100	115	100	0.7	155002
100	110	121	120	0.7	TXB10NP01
125	130	150	120	1	TXB12NLOG
150	150	175	120	1	TXB15NMOJ
200	200	225	150	1.5	TXB20NLOK
300	310	335	190	2.9	TXB30NN02

* minimum / maximum external diameter of the pipes to be connected

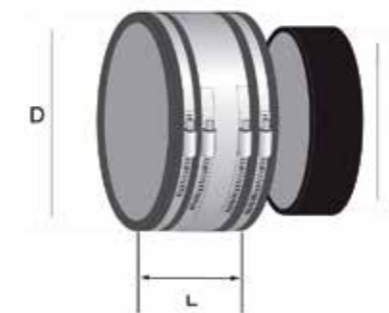

ADAPTING COLLAR AND STEPPING RING

DN	D min.*	D max.*	d min.*	d max.*	L	Weight	Product code
200	200	225	192	201	150	1.9	TXB20NNOK

* minimum / maximum external diameter of the pipes to be connected

"All dimensions are in mm and nominal weights are in kg"



ADAPTING JOINTS

DN	D min.*	D max.*	d min.*	d max.*	L	Weight	Product code
150	155	170	130	145	120	0.8	155003
200	170	193	210	235	150	1.5	155004

* minimum / maximum external diameter of the pipes to be connected



PAM Konfix-Multi

DN	D1	D	Ext. Ø Connecting pipe mm	L1	L	Insert depth mm	Weight	Product code
100	108	134	32-56	36	91	40	0.3	176811

For connecting up to three 32-56 mm pipes made out of other materials to a cast iron pipe system DN 100. EPDM and hose clamp made of chrome steel no. 1.4016.

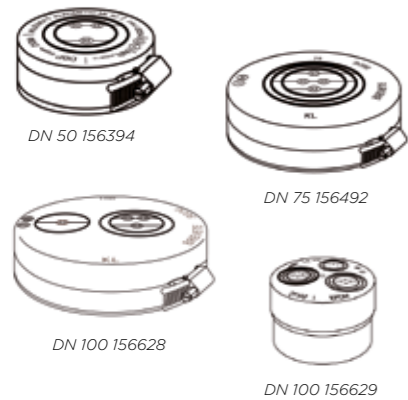
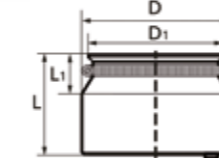
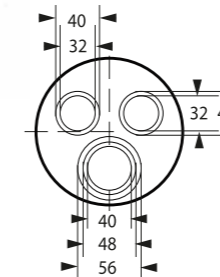

EPDM PLUGS

DN	1st aperture ø in mm	2nd aperture ø in mm	3rd aperture ø in mm	Weight	Product code
with stainless steel collar					
50	32 or 40 or 42	-	-	0.1	156394
75	(32 or 40) or (42 or 50)	-	-	0.2	156492
100	32 or 40 or 42	32	-	0.3	156628
without stainless steel collar					
100	(32 or 40) or 42	(32 or 40) or (42 or 50)	(32 or 40) or (42 or 50) or 54	0.4	156629



PAM Multiquick

DN	Ø D1	Ø D2	Ø D3	Ø D4	Ø d1	Ø d2	Ø d3	Ø d4	H	Weight	Product code
100x70	117	111	101	81	108	104	94	74	107	0.15	176812

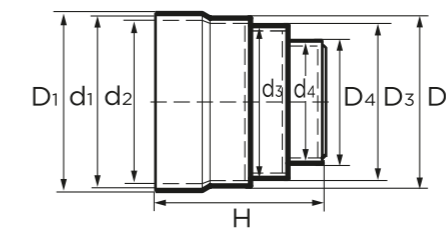

The Multiquick connector DN 100x70 allows connections between other materials with an outside diameter from 72 to 110 mm, to our cast iron range DN 100 with a maximum outside diameter of 115 mm. There are several pre-cut options. EPDM and hose clamp made of chrome steel no. 1.4016.



PAM Konfix

DN	D1	D	Ext. Ø Connecting pipe mm	L1	L	Insert depth mm	Weight	Product code
50	50	72	40-56	20	58	35	0.1	155759
75	82	92	56-75	22	72	45	0.16	180852
100	100	126	102-110	28	90	57	0.3	155833
125	125	151	125	36	106	65	0.7	155883

Transitional connectors DN 50-125 are designed for connecting the cast iron S and Plus ranges to other materials, whether steel or plastic. The connections with these flexible connectors are easy and safe: one pre-cut lid and a lip seal inside (see figure). EPDM and hose clamp made of chrome steel no. 1.4016.

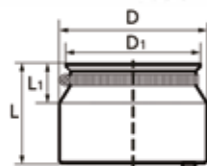

"All dimensions are in mm and nominal weights are in kg"

"All dimensions are in mm and nominal weights are in kg"

BRACKETS



Quick hooking thanks to the opening

«802» COLLARS

DN	Nut	Tightening screw	a	Weight	Product code
50	M8	Screw M6 (Key of 10)	11	0.08	251138
75	M8	Screw M6 (Key of 10)	11	0.1	251188
100	M8	Screw M8 (Key of 13)	11	0.19	251189
125	M8	Screw M8 (Key of 13)	11	0.23	251177
150	M8	Screw M8 (Key of 13)	11	0.25	251178
200	M10	Screw M8 (Key of 13)	14	0.46	255005
250	M10	Screw M8 (Key of 13)	14	0.68	255006
300	M10	Screw M8 (Key of 13)	14	0.79	255007

In galvanised steel.
Distance between pipe and wall: 1 cm.



RUBBER-LINED STEEL BRACKET

DN	Nut	Tightening screw	a	Weight	Product code
50	M8/10	Screw M6 (Key of 10)	24	0.1	251197
75	M8/10	Screw M6 (Key of 10)	24	0.3	251198
100	M8/10	Screw M8 (Key of 13)	25	0.3	251199
125	M8/10	Screw M8 (Key of 13)	25	0.4	251200
150	M10	Screw M8 (Key of 13)	18	0.6	251201
200	M10	Screw M8 (Key of 13)	19	1.6	251202
250	M12/16	Screw M12 (Key of 19)	41	1.8	251203
300	M12/16	Screw M12 (Key of 19)	41	2.9	251204

Quick hooking thanks to the opening



SUSPENSION HOOKS «101»

DN	Weight	Product code
50	0.04	255008
75	0.05	255009
100	0.08	255010
125	0.11	255011
150	0.16	255012
200	0.33	255013
250	0.45	255014

- Fixing settings**
- > Ease of fixation thanks to a 4 cm opening in the upper part of the hook
- Reduced bearing surface**
- > Recesses to address wall roughness
- Automatic set up**
- > Level marking on the hook that represents the waterline
 - > AS13 aluminium / not corrodible

ACOUSTIC DAMPENER

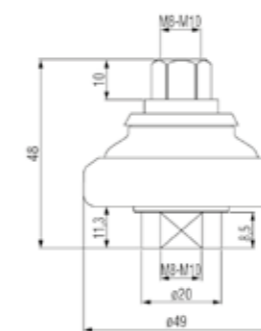

PAM ACOUSTIC

DN	Weight	Product code
50 to 150	0.11	205113

CANTILEVER ARMS

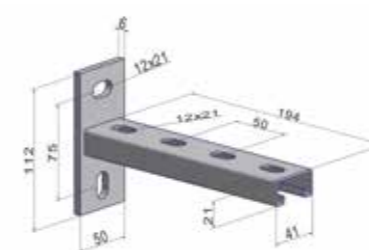

CANTILEVER ARM 41/21/2 LG 200 - DN 50 AND 75 GALVANISED STEEL

DN	L	F*	Weight	Product code
50	200	150	0.5	251209
75				

* F: Maximum load for 2 arms, when applied at mid-length of the arm (L/2), in daN



Quick hooking thanks to the opening

SUSPENSION HOOKS «401»

DN	Tightening screw	Weight	Product code
50	M8	0.12	251179
75	M8	0.14	251180
100	M8	0.16	251191
125	M10	0.25	251192
150	M10	0.3	251193
200	M10	0.4	251194
250	M12	0.8	251195
300	M12	1	251196

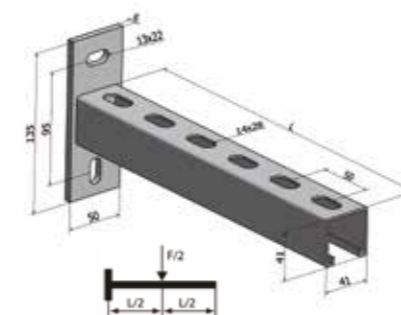

CANTILEVER ARM 41/ 41/ 2 LG 300 - DN 100 TO 150 GALVANISED STEEL

DN	L	F*	Weight	Product code
100				
125	300	300	0.9	251210
150				

* F: Maximum load for 2 arms, when applied at mid-length of the arm (L/2), in daN

"All dimensions are in mm and nominal weights are in kg"

"All dimensions are in mm and nominal weights are in kg"

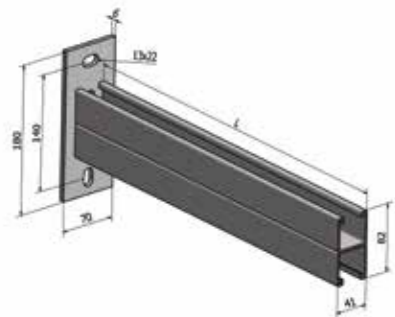

CANTILEVER ARM 41/ 82/ 2 LG 450 - DN 200 TO 300 GALVANISED STEEL

DN	L	F*	Weight	Product code
200				
250	450	500	2.4	251211
300				

* F: Maximum load for 2 arms, when applied at mid-length of the arm (L/2), in daN

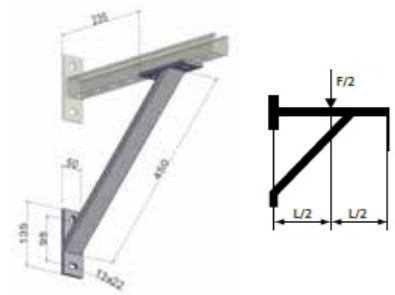

REINFORCEMENT FOR CANTILEVER ARM 41/82/2 LG 450 GALVANISED STEEL

DN	L	F*	Weight	Product code
200				
250	450	800	2.4	251212
300				

* F: Maximum load for 2 arms with reinforcement, when applied at mid-length of the arm (L/2), in daN



FIXATION BOLTS FOR CANTILEVER ARMS

DN	Weight	Product code
Cantilever arm 50 to 200 Reinforcement fixation	M12x60 0.02	251208
Cantilever arm 250 and 300	M16 x70 0.03	252587

STACK SUPPORT FIXING KIT

Galvanised zinc in combination with stack support bracket

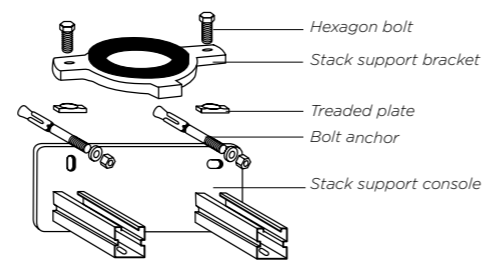

DN	Description	Kit contents	Plate dimension	Hole spacing / Rail axial dimension	Hole ø	Weight	Product code
50	FRK 50 SET	1 x Stack support console 262 SP45 1 x Stack support bracket DN 50 or DN 75 2 x Hexagon bolt M12x35	100x205x6	150	14 x 24	3.66	235621
75	FRK 75 SET	2 x Threaded plate GWP 45/12 Z 2 x Bolt anchor BZ 12-30/125 M 12	100x225x6	170	14 x 24	3.94	235622
100	FRK 100 SET	1 x Stack support console 315 SP45 1 x Stack support bracket DN 100 or DN 125 2 x Hexagon bolt M12x35	100x269x8	214	14 x 24	5.35	235623
125	FRK 125 SET	2 x Threaded plate GWP 45/12 Z 2 x Bolt anchor BZ 12-30/125 M 12	100x283x8	228	14 x 24	5.53	235624

"All dimensions are in mm and nominal weights are in kg"

TOOLS



EXACT SAW MACHINE

Description	DN	Product code
Exact PipeCut + Bevel 170E machine	50-150	280632
Disc bevel x140 (Exact PipeCut + Bevel 170E)	50-150	280633
Disc cut x140 (Exact PipeCut + Bevel 170E)	50-150	280634



PAINTS AND PROTECTION



TOUCH-UP PAINT "EXTREM 1" RED

Quantity	Product code
250 ml	226788
500 ml	226962

After any cutting operation, the pipe ends must be protected by applying EXTREM 1. EXTREM 1 is a ready-to-use quick drying touch-up paint that air dries in 15 minutes. It is easily applied with a brush (included in the paint bucket)

TOUCH-UP SPRAY PAINT (400 ML)

Colour	Product code
"S range" red-brown color	257025
"Plus range" grey color	257027
"Residential (Type R)" color	257028
"ITINERO" grey color	262704



"All dimensions are in mm and nominal weights are in kg"



06

DESIGN & INSTALLATION

- 148 RESISTANCE TO PRESSURE
- 154 VENTILATION
- 157 ACCESS TO NETWORK
- 158 NETWORK SUPPORTING
- 162 JOINTING METHODS
- 164 CONNECTION TO OTHER MATERIALS
- 169 MULTI-WASTE
- 170 BURIED NETWORK
- 172 EPAMS®
- 177 GENERAL INSTALLATION INSTRUCTIONS
- 180 DISCHARGE CAPACITY



REQUIREMENTS AND ADMISSIBLE PRESSURE LOAD

Standard requirements according to EN 12056

Gravity wastewater drainage systems and ventilation systems generally operate without pressure. Although this does not exclude the possibility of pressure arising in the systems under specific operating conditions.

EN 12056-1, Section 5.4.2 Water and Gas Tightness, states that drainage installations must be sufficiently water and gas tight to withstand operating pressure. Furthermore, EN 12056-5, Section 6.3 states, with respect to securing pipe systems: Non-anchored pipes must be secured and/or supported in such a manner that they cannot be disconnected during use. The arising reaction forces must be addressed. For the specific application of rainwater, EN 12056-3, Section 7.6.4. stipulates: Internal rainwater pipes shall be able to withstand the head of water likely to occur in the event of a blockage. The same precautions should be taken as on pipework liable to undergo accidental overloading: securing of bottom bends and joints with adequate grip collars or HP couplings.

Definitions

Fluid pressure is the force the fluid exerts per surface unit, perpendicular to this surface. Pressure change applied to the surface of an enclosed fluid is transmitted evenly and undiminished in all directions. Robust cast iron components can address any pressure hazard, so the couplings will be subjected to the strain. Couplings designed by PAM building are tested under hydrostatic pressure; only grip collars and autogrip collars are tested under end thrust forces.

NETWORK REQUIREMENTS AND ADMISSIBLE PRESSURE LOAD

In addition to the above standards, in a drainage network, pressure resistance requirements are dependent on:

- > The height of the water column between the considered point of the network and the first outlet located upstream; generally speaking, we differentiate waste and toilet networks from rainwater.
- > The accidental risk of loading. The most frequent cases are due to occasional obstruction of downstream pipeline or saturation of the public network.



WASTEWATER NETWORKS

Risk of pressure build-up with a low water column

Generally, the pressures that occur in wastewater drainage systems cannot exceed the pressure corresponding to the height of one storey, i.e. about 0.3 bar, as sanitary appliances on each floor serve as outlets in case of accidental overloading. The couplings we describe as "standard" (PAM Rapid and PAM R) meet these requirements.

Risk of pressure build-up with a high water column

In very rare cases, where domestic wastewater downpipes cross several levels of a building without any outlet, and where there would be a risk of accidental loading, the installation must comply with the recommendations applicable to rainwater networks.

RAINWATER NETWORKS

Risk of pressure build-up with a low water column

Same as wastewater networks.

Risk of pressure build-up with a high water column

In some rare cases there could be a risk of accidental overloading. The pressure resistance required to ensure these systems remain leak tight and stable depends on the height of the water column liable to occur, and could call for high-pressure couplings able to withstand the resulting pressure (up to 10 bar).

Coupling solutions will be differentiated for building height between 0 to 30 m, 30 to 50 m, 50 to 100 m corresponding to different levels of pressure resistance requirements.

> Straight runs of the pipework

Straight runs between two fixed points and rigid bracketing do not experience exceptional forces. In case of accidental overloading, the couplings will only have to address hydrostatic pressure. Standard pressure couplings withstand up to 10 bar for DN50-DN125, up to 3 bar for DN250-DN300. High pressure couplings withstand up to 10 bar for DN100-DN400 and up to 6 bar for DN500 and DN600.

> Changes of direction and specific elements (plugs, branches, bends)

End thrust forces can be exerted with changes of direction, gradient and specific components like branches and plugs. These forces have to be addressed to avoid any risk of the pipe system disconnecting or slipping using specific couplings.

It is considered that end-thrust effect must be addressed when drainage pipework may be exposed to an internal pressure higher than 0.5 bar.

In such conditions, the installation must be able to stay in place to perform its functions of water tightness, and mechanical stability, preventing any dislocation at the couplings. Grip collars and gripped HP couplings are part of the solutions to secure the network.

End thrust effect:

The result of the pressure forces exerted by a stationary fluid on the singular points of a pipe (or changes in direction), thus:



> **Straight runs (pipes):**
the forces cancel each other out.

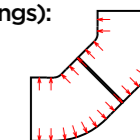

> **Singular points (e.g. fittings):**
the resultant forces tend to dislocate the network.

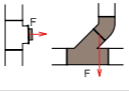

The forces significantly increase with large pipe diameter as illustrated in the following table.

	DN50	DN75	DN100	DN125	DN150	DN200	DN250	DN300	DN400	DN500	DN600
Expansion plugs or single long arm branches 	10.5	22.5	41.5	63.5	90.5	157	269.5	387	666.5	1029	1475
Two 45° bends 	14.5	32	59	95	127.5	225.5	382	544	941	1455.5	2087.5

Thrust effect under 5 m water column (daN), corresponding to a 0.5 bar pressure.

It is considered that end-thrust effect must be addressed for:

1. Pipes laid under the groundwater table
2. Rainwater pipes or wastewater pipes running through several stories without outlets
3. HP ≥ 5 m
4. EPAMS – gripped collars or gripped couplings are mandatory until positive pressure is reached.

In these areas, the forces have to be addressed to avoid any risk of the pipe system disconnecting or slipping:

- > Isolating the section suspected of having thrust forces between two fixed points, like stack support pipes.
- > Adapting the joints (selection of couplings solutions) between these fixed points.

To address the thrust forces, other solutions can be used, like anchoring in concrete, or using dedicated bracketing systems.

COUPLING SELECTION ACCORDING TO LOADING RISKS

Couplings + Grip collars: performance

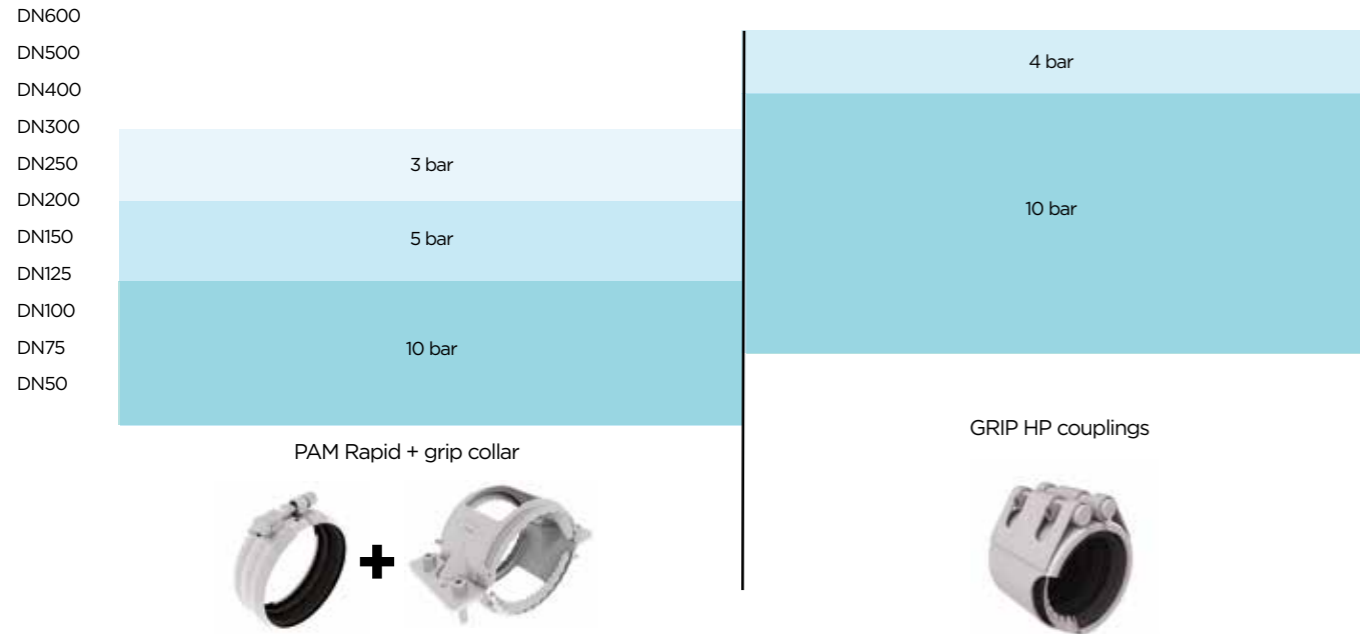

Note: under end thrust forces, where a coupling is secured with a grip collar, the maximum performance of both is limited by the weakest performance of the two products.

Focus on the PAM grip collars installation



Position the two half parts of the PAM grip collar uniformly so it encircles the pipe in parallel. The grip collars must be positioned so that the apertures fit over the coupling's fixing bolts and the teeth are directly located onto the pipe.

Insert the four screws to fix the two parts together loosely.

Tighten the screws crosswise alternately so that the two plates are put in parallel with the same spacing.

The assembly is completed when the external edges of the plates are in contact on both sides.

> How to select the right coupling?

Before deciding which type of coupling to use it is important to answer the following questions:

• **Wastewater or rainwater network?**

> Generally, the pressures that occur in wastewater drainage systems cannot exceed the pressure corresponding to the height of one storey, i.e. about 0.3 bar, as sanitary appliances on each floor serve as outlets in case of accidental overloading.

• **Diameter of the pipes?**

> Thrust forces will be significantly larger for large diameter pipes and will have to be addressed with grip collars and HP couplings. Pressure resistance of couplings are specific for a given diameter. For DN 400 and larger only HP couplings are available.

• **Height of the stack?**

> The higher the stack is, the higher the potential pressure build-up.

• **Location of the coupling along the system?**

> Recommendations will change between $0\text{ m} < H \leq 30\text{ m}$, $30\text{ m} < H \leq 50\text{ m}$, and $50\text{ m} < H \leq 100\text{ m}$ as the height of the water column will correspond to different pressure levels.

• **Straight run or change of direction?**

> Thrust effort will have to be addressed at change of directions.

> Wastewater network DN 50 to DN300

Different coupling recommendations should be followed depending on the number of floors and the HP height. In case of several storeys without outlet, the installation must comply with the recommendations applicable to rainwater networks.

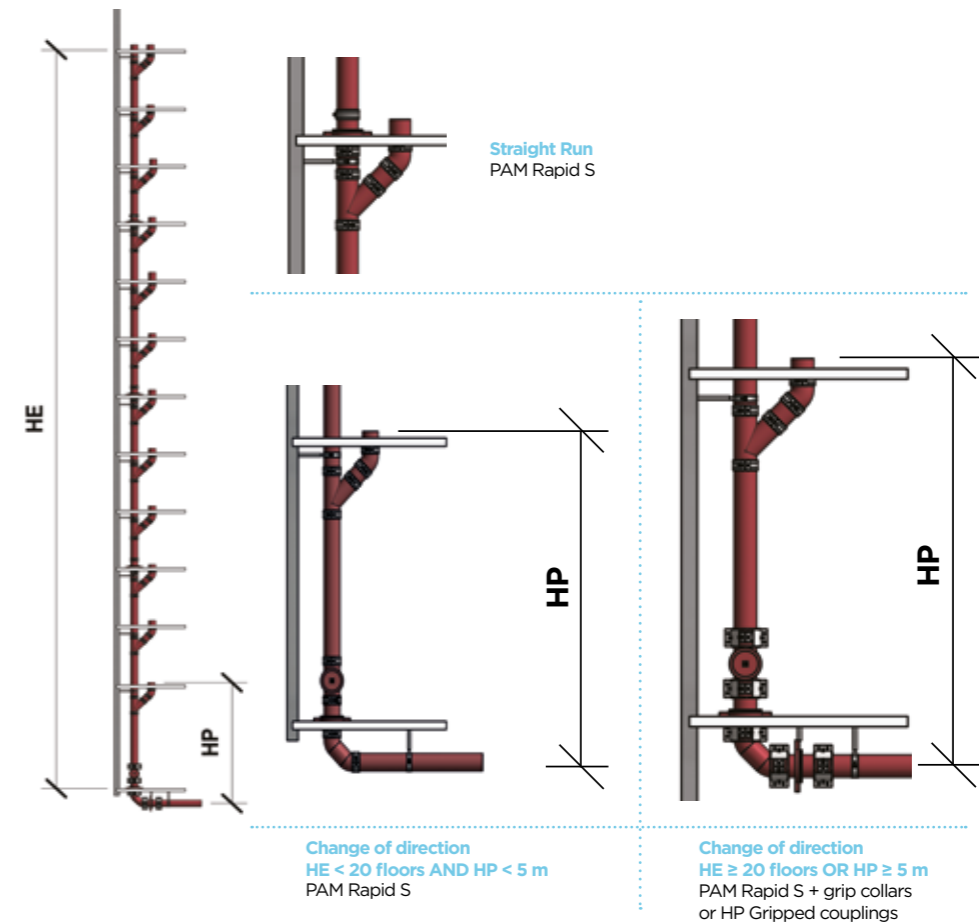

> Rainwater network DN100 to DN125

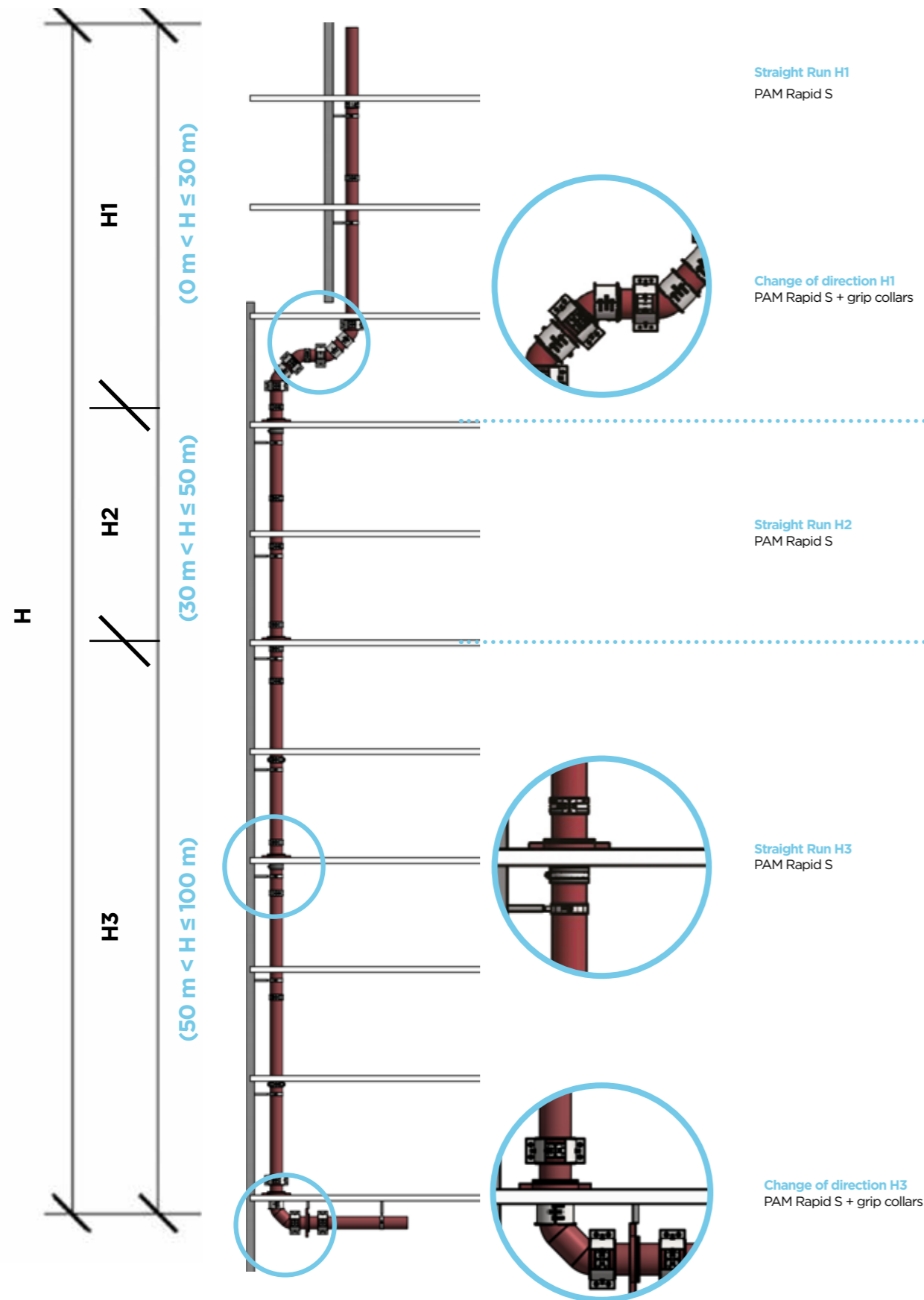

> Rainwater network DN150 to DN200

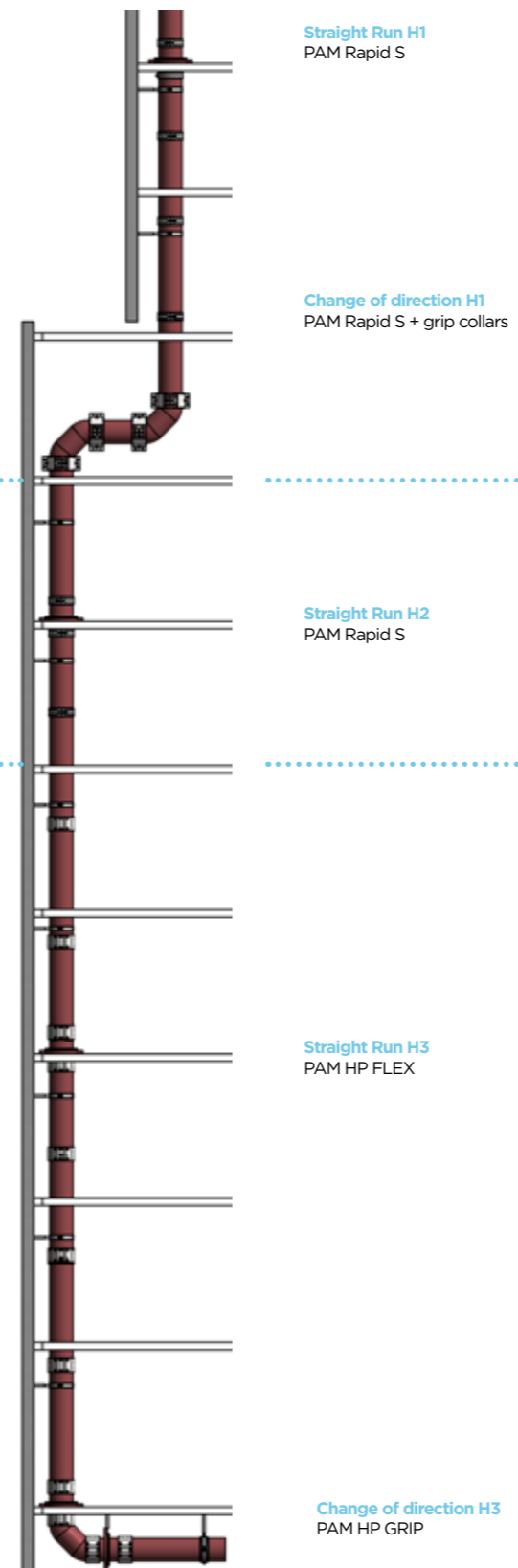

> Rainwater network ≥ DN250

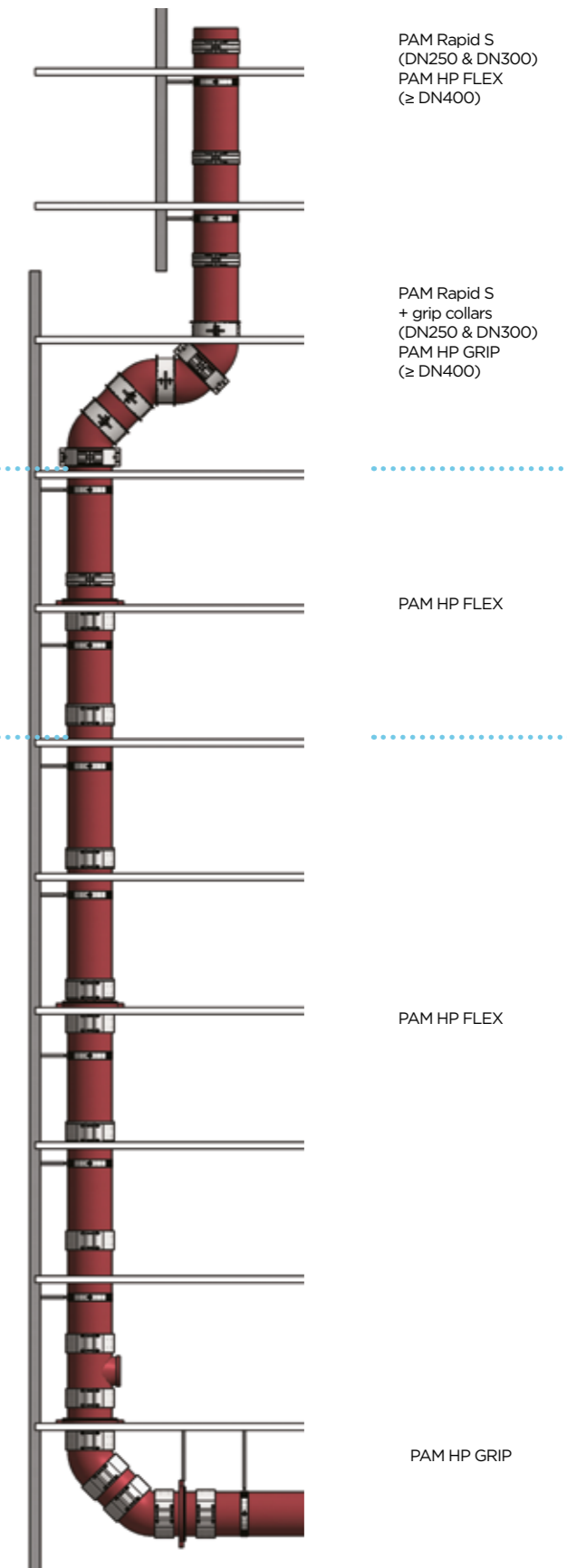

A drainage pipe is normally at neutral air pressure compared to the surrounding atmosphere. When a column of wastewater flows through a pipe, it compresses air in the pipe, creating a positive pressure that must be released or it will push back on the waste stream and downstream traps' water seals. As the column of water passes, air must flow in behind the waste stream or negative pressure (suction) results. The extent of these pressure fluctuations is determined by the waste discharge fluid volume.

The purpose of a ventilation stack is to control pressure in the pipework to prevent foul air from the wastewater system entering the building. Below are some of the main configuration principles, but combinations and variations are often required (see standard EN 12056-2). The purpose of a ventilation stack is also to avoid accumulation of dangerous gases.

Black water and grey water can be drained either in separate or in a single discharge stack. The rules for duct sizing are different depending on the option selected.

Primary ventilated system configurations:

Control of pressure is achieved by air flow in the discharge stacks. The soil stacks extend in main roof vents to above and out of the roof. Alternatively, air admittance valves may be used. They are pressure-activated, one-way mechanical vents, used in a plumbing system to eliminate the need for conventional pipe venting and roof penetrations.

A single stack is still possible but design precautions must be taken to prevent self-siphonage.



Secondary ventilated system configurations

In buildings of three or more storeys, if the air pressure within the stack suddenly becomes higher than ambient, this positive transient could cause wastewater to be pushed into the fixture, breaking the trap seal.

Vent stacks are put in parallel to waste stacks to allow proper venting and prevent such disorders. Air admittance valves may also be used in this configuration.

Under many building codes, a vent stack, a pipe leading to the main roof vent, is required to the draining fixtures (sink, toilet, shower stall, etc.).

To allow only one vent stack and therefore one roof penetration, as permitted by local building codes, sub-vents may be tied together and exit a common vent stack.

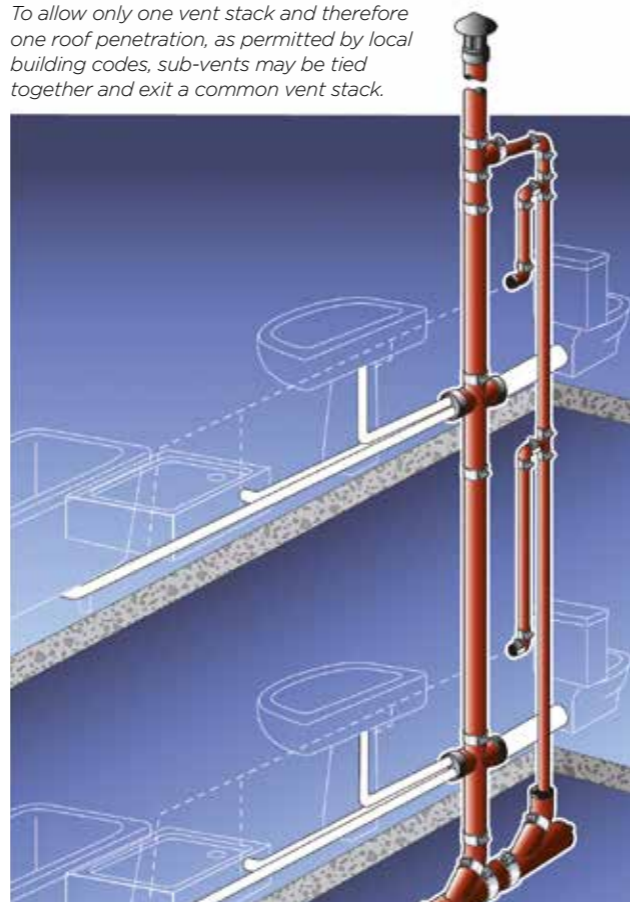

SINGLE STACK BRANCH

The single stack branch is a patented device made to allow wastewater drainage without secondary vent pipes.

Provided the maximum number of connected sanitary appliances is respected, the single stack branch properly drains wastewater in a single stack, without vent pipes, whilst limiting the risks of self-siphonage. This device complies with the regulation and with standard EN 12056. The branch for a single downpipe allows wastewater drainage in a combined network without secondary ventilation according to EN 12056.

**Consult local requirements for compliance.*

Field of use:

- > Multi-connection of sanitary appliances for adjacent apartments, or sanitary blocks
- > Compactness when space is limited
- > No secondary vent pipes are required.

Benefits: It simplifies plumbing by grouping pipework from 3 or 4 times more sources than a conventional installation. Maximum connections for each floor level: 2 toilets, 2 bathtubs and all the usual sanitary facilities for two apartments (sinks, basins, showers, etc.). The single stack branch is particularly suitable for narrow service shafts, hotel rooms, student apartments or any other building with adjacent sanitary blocks.

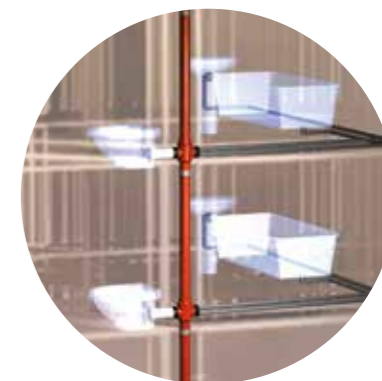

Operation features

- > System under French Technical Approval.
- > Prevents excessive pressure variations in the stack system.
- > Limits negative pressure by optimal venting and prevents self-siphonage.

The single stack branch DN 100 main body is connected to the stack using standard couplings and a traditional jointing method. Their watertightness is ensured by the rubber gaskets which equip the S and Plus ranges offered by PAM Building.

The overall plumbing works shall be executed in compliance with standard EN 12056: the appliances shall be installed with traps in compliance with the specifications of the same standard.

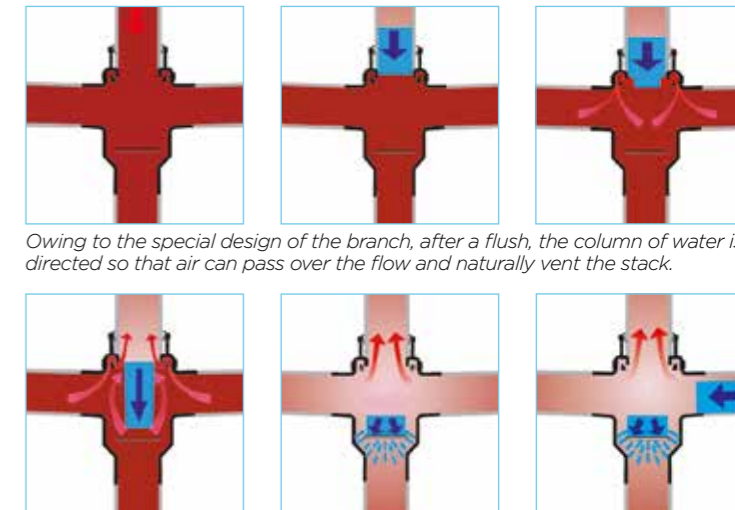

Owing to the special design of the branch, after a flush, the column of water is directed so that air can pass over the flow and naturally vent the stack.

Inside the branch, at the bottom of the body, a rubber deflector sprays the column of water to prevent draught or self-siphonage.



Solution

The single stack branch exists as a long tail to allow connection to the main stack under the slab and thus facilitate installation either in new or renovation works.

Three different products, 2 or 3 inlets:

- > Corner branch two inlets 88°
- > Double branch two inlets 88°
- > A consecutive branch, three inlets 88°

Rubber plugs with several pre-cut lids will allow one to three different connections.

WATER FLOW AND AIR CIRCULATION, ACCORDING TO STANDARDS EN 12056-2 AND EN 12056-3

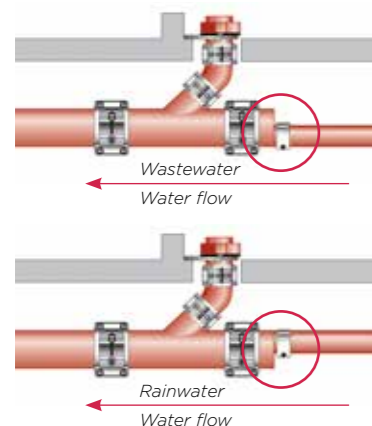

The internal diameter of pipes cannot be reduced in the direction of the water flow, except in the case of pipework operating at full bore, under negative pressure such as in the EPAMS siphonic roof drainage system. The addition of branch connections, or changes of fall liable to increase the water flow rate, may require an increase in internal pipe diameter. This increase can be applied upstream of the new branch connection, using a tapered pipe (see p.98).

Rainwater horizontal pipelines

In horizontal and near horizontal pipelines, increases in size shall be installed so that the soffit is continuous, to prevent air from being trapped.

ROOF PENETRATION DEVICE

To secure roof watertightness, which is of crucial importance, the number of roof penetrations should be limited. PAM Building has designed a roof penetration device for its pipe systems that is watertight and quick to install.

The system was developed to facilitate the installation of completely watertight roof penetration for cast iron primary ventilation pipes or vent pipes. The flanged fittings clamp both the vapour barrier and the waterproofing layer.



The roof penetration device is a set of two ductile iron flanged fittings - one of the flanges is fixed, the second is movable - equipped with rubber gaskets. Rubber gaskets are available in EPDM or NBR quality where hydrocarbons may be present.

See product codes on p.103

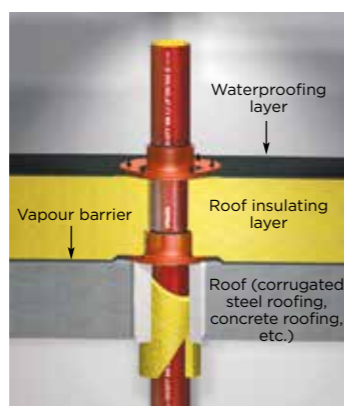

The first flange fitting, installed above the roof, clamps the vapour barrier under the roof insulating layer, the second, above the insulating layer, clamps the waterproofing layer, whether it is polymer or bituminous.

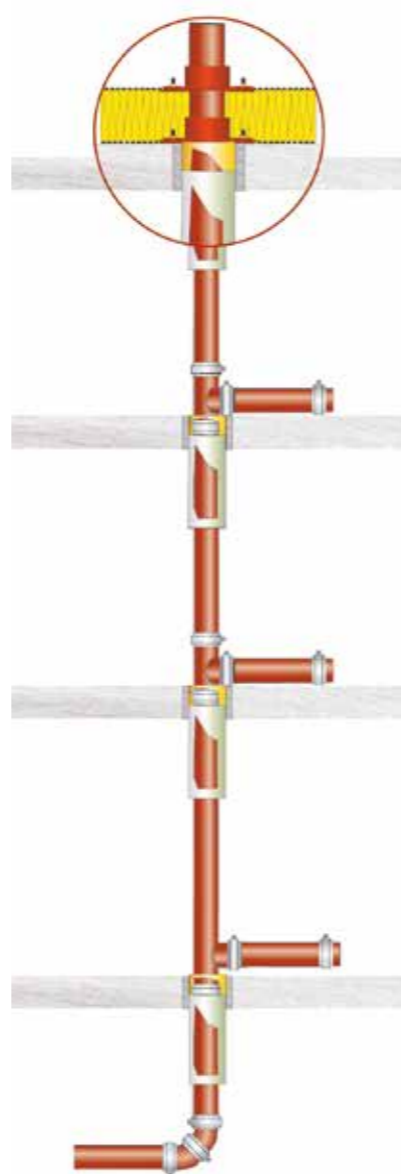

ACCESS TO THE PIPEWORK

Access to the pipework must be ensured so that tests, inspections and maintenance can be performed. Access may be obtained using a short access pipe.

On downpipes

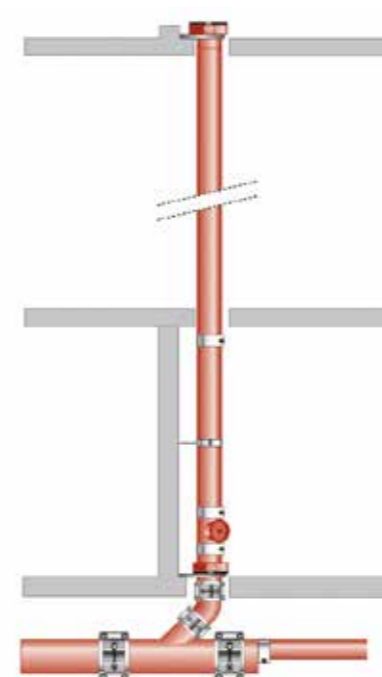

At the bottom of the stack.

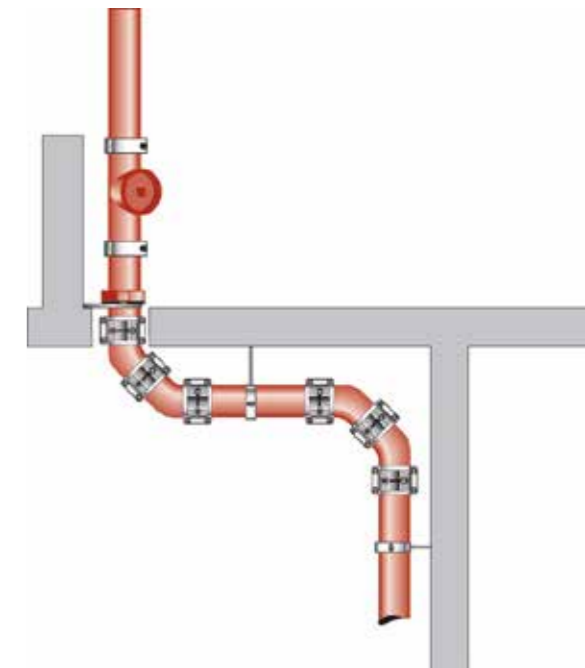

At changes of direction (stack offsets).

On horizontal collectors

On horizontal runs, the short access pipe will be installed in a slightly sloped position with respect to the pipe crown.

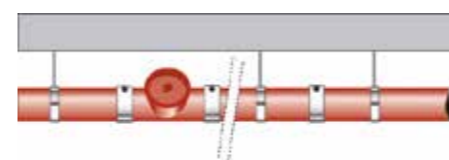

The short access pipe combines reliability, ease of use and operation safety:



BRACKETING: TECHNICAL

Pipe support except for the EPAMS® system

For cast iron, the bracketing system is designed to only carry the weight of the pipe and its content, which makes the specifiers' design work easier.

Pipe weight in kg per metre

	50	75	100	125	150	200	250	300	400	500	600
Empty pipe	4.5	6	8.5	12	14.5	23.5	33.5	44	60	82	107
Full pipe	6.5	10	18	25	32.5	55	88	121.5	185	278	390

Note: The technical specifications for threaded rods and metal brackets shall be established on this basis.

Bracketing recommendations for cast iron pipe system elements

		Number of brackets	Consult local requirements for compliance.
Vertical run	Pipes	1 (2)*	
	Fittings**	1	
Horizontal run	Pipe length ≥ 2 m	2	
	Pipe length < 2 m	1	
	Fittings**	1	

* For PAM-GLOBAL® pipes L ≥ 2.7 m installed outdoors.

It is also recommended to use one bracket per length or fitting (when the shape allows it, i.e. branches, etc.)

Support for horizontal pipework

The general recommendation for horizontal pipework is two load bearing brackets per pipe. As an indication, they should be installed 0.75 m from each spigot so that, ideally, the distance between two brackets is 1.5 m. Installation shall respect a slight fall, around 1 or 2%, and 0.5% as a minimum, (0.5 cm per metre).

Support for vertical pipework

For vertical waste or rainwater stacks, the brackets aim to prevent the pipework from falling over. It is recommended that one bracket be fitted for each floor level.

Ideally, the bracket should be installed on the first third of the upper spigot, and even closer to a socket joint.

At the bottom of the stacks, the forces from the pipe's weight and possible end thrust efforts will preferably be addressed through stack support pipes.

Bracketing installations, openings and sealings are prohibited in pre-stressed girders.

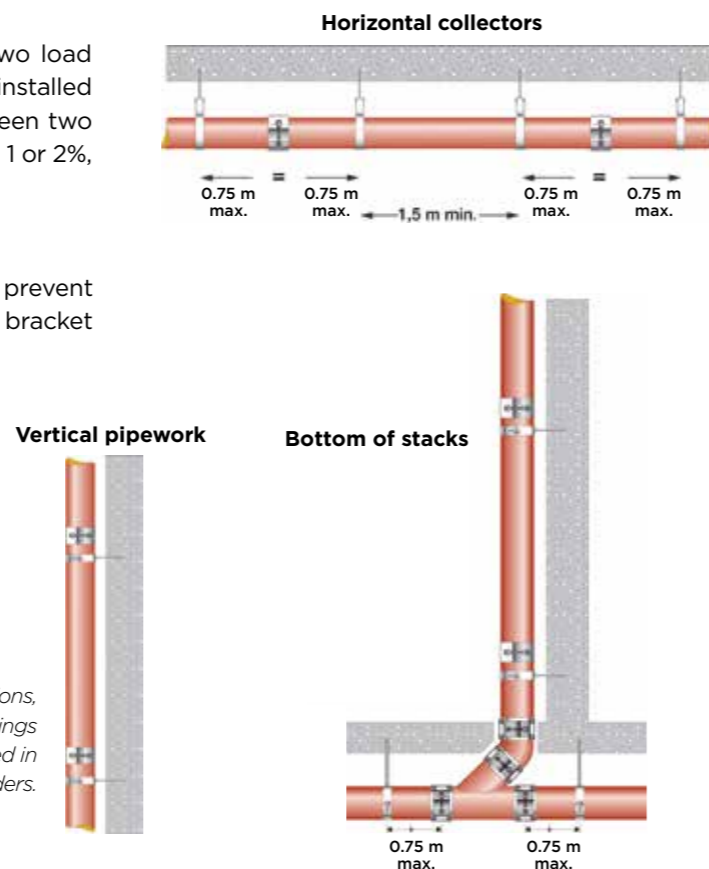

SPECIFIC BRACKETING FOR ACOUSTIC INSULATION

The evacuation of waste, soil and rainwater generates structure-borne and airborne sound between rooms and usually occurs as a result of a mixed flow, when the pipe is filled with water and air. In such circumstances a pipe will radiate noise outwards and transfer it to any lightweight ceilings, cupboards and similar areas wherever it makes contact.

PAM Acoustic dampener

All brackets within the PAM Building range meet the requirements of the most demanding standards. For high levels of acoustic performance, the standard steel brackets fitted with a new acoustic dampener should be used. The different assemblies have been tested to EN 14366: Laboratory measurements of noise from wastewater installations. The PAM acoustic dampener has been developed to meet the increasing demand for buildings to have a high level of acoustic performance above regulatory requirements.

Pipe installation fitted with acoustic dampener*
Structure-borne noise according to part 03:
2 l/s < 10 dB(A)
4 l/s < 10 dB(A)

* IPB 2019 tests results, installation according to EN 14366.



Sound insulation in bracketing

Function

The acoustic dampener is mounted between the wall or ceiling and the pipe bracket and dampens the noise generated in drainage pipe systems. It can be used with M8 and M10 thread rods.



1. Dampener - elastomer EPDM
2. M8-M10 - threaded nut; galvanised steel
3. Stainless steel housing, A2
4. Thread connection with 17 mm key value; galvanised steel.

Assembly



1. Fasten the PAM Acoustic Dampener to the thread in the wall with an open-end wrench.
2. The second threaded rod connects the acoustic dampener and pipe bracket.
3. Fix. Finished!

2 possibilities for fixing the PAM Acoustic Dampener on a Pipe Bracket:

1. Vertical lines:

Each end of the acoustic dampener can be fixed to the bracket. For each 3 m of length minimum 1 dampener must be used.

The weight of the pipes and the resulting water pressure must be absorbed by other devices: grip collars, stack supports, etc.



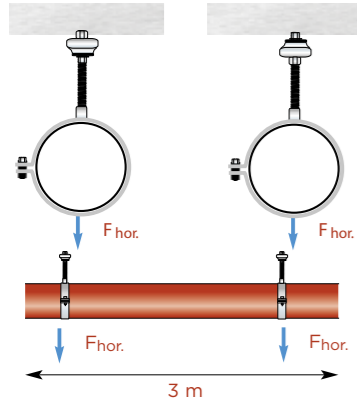

2. Horizontal lines:

Each end of the acoustic dampener can be fixed to the bracket. At a length of 3 metres, 2 dampeners must be used.

With each type of fixation, the best effect can only be achieved if the components are neither deformed nor compressed.

Maximum horizontal load F per dampener: 100 daN.

Prohibited assembly

This mounting leads to rotation / torsion of the elastomer, which means the dampener cannot work properly and the elastomer might be cut. Therefore, this type of fixation is not allowed.

ATTENTION: This assembly causes the elastomer to twist

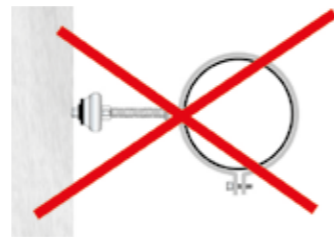

PIPEWORK STABILITY

Stack support pipe

Pipework is subject to different forces liable to affect its stability. Stack supports are cast iron components designed to address these efforts.

On straight runs, stack support pipes should be installed to address the pipes' weight. At the bottom of the stack, the first stack support pipe addresses both the pipes' weight and the end thrust effort. For the last case, it is recommended that the support and fixings be adapted accordingly.



We recommend positioning the first stack support pipe at the base of the first floor, and then every subsequent fifth floor, in the case of a standard average 2.5 m between floors, or more generally every 15 m.

In the case of a wall or slab opening closed by mortar, thus constituting a fixed point, no stack support pipe is required.

Stack support pipe and acoustic insulation



The support bracket of the stack support is covered with a rubber gasket to limit the transmission of structure-borne noise emitted by the drainage network at slab level. During laboratory tests carried out in 2019*, a stack assembly including a stack support pipe on a console support and a rubber-lined bracket, both fixed to a wall with a surface density of 220 kg/m², showed slightly better results than the same installation made with two fixings with rubber-lined brackets. In this particular installation, the use of stack support pipes does not affect acoustic performance.

Rubber gasket
Stack support console

*Tests carried out according to standard EN 14366.

Admissible load for stack support console (see products on p.144).

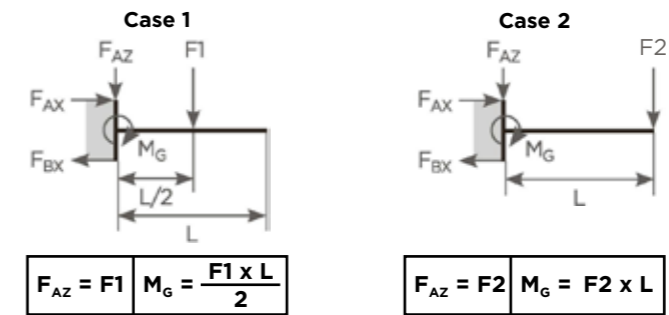

Description	Length (mm)	Case 1 F1 (kN)	Case 2 F2 (kN)
Stack support console 262 FRK 50 Set	262	2.3	1.15
Stack support console 262 FRK 75 Set	262	2.3	1.15
Stack support console 315 FRK 100 Set	315	3.3	1.65
Stack support console 315 FRK 125 Set	315	3.3	1.65

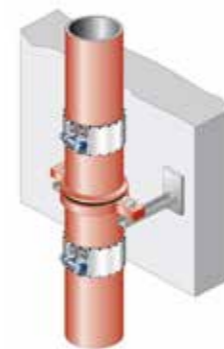

Stack support pipe installed vertically

Either on cantilever arms or stack support consoles up to DN 125.

Stack support pipe installed horizontally

A wall bracketing system is available in mild steel, for use with stack support pipes and brackets.



Admissible load for cantilever arms (see products on p.143-144).

	Reference	Diameters	Length (L in mm)	Admissible load (F in daN)
Case 1	Cantilever arm 41/21/2 LG 200	50 - 75	200	150
	Cantilever arm 41/41/2 LG 300	100 - 125 - 150	300	300
	Cantilever arm 41/82/2 LG 450	200 - 250 - 300	450	500
Case 2	Reinforcement for cantilever arm 41/82/2 LG 450	200 - 250 - 300	450	800

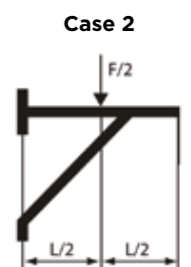
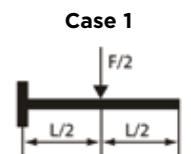

STAINLESS STEEL COUPLINGS

ASSEMBLY AS A SLEEVE PAM Rapid Couplings (S and INOX) > DN 50 to 200

Couplings are supplied pre-assembled. The PAM Rapid from DN 50 to 200 is designed to be tightened to fully closed, there is no need to check the torque.



1 - Push the supplied assembled coupling onto the pipe spigot so that it abuts on the central register of the elastomer gasket.

2 - Push the next pipe spigot into the other end of the coupling.

3 - Tighten the screw to "zero gap" position, i.e. fully closed, with a ratchet spanner or electric screwdriver.

> DN 250 to 300

They can be assembled in two different ways, depending on whether an open strap is required.

Standard assembly:

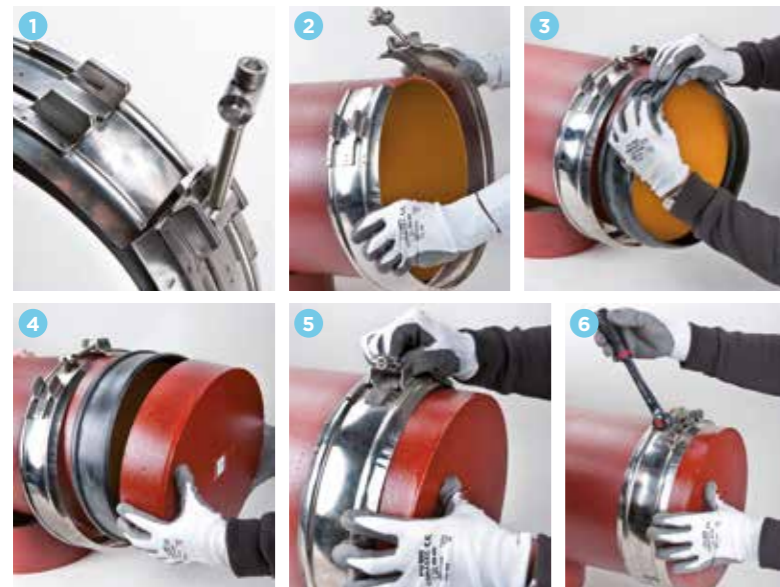

- 1 - Open the stainless steel strap.
- 2 - Slide the stainless steel strap loose around the first pipe component.
- 3 - Push the sealing gasket onto the component spigot so it abuts on the central register of the gasket.
- 4 - Push the second component into the sealing gasket, so that it abuts on the central register.
- 5 - Bring the steel strap over the sealing gasket.
- 6 - Tighten the bolt with a ratchet spanner or a power tool applying the following tightening torque: DN 250 and DN 300 = 25 N.m.

Open strap assembly:

An open strap is sometimes required to facilitate access: stack installation, etc.



- 1 - Push the rubber gaskets onto the spigot ends top and bottom, ensuring the central registers are abutted against each spigot edge.
- 2 - Twist the stainless steel strap to ease the wrapping around the pipe components.
- 3 - Clip the bolt and loosely assemble the coupling around the gasket.
- 4 - Check the alignment of the assembly before tightening the bolt with a ratchet spanner or a power tool, applying the following tightening torque: DN 250 and DN 300 = 25 N.m.

ATTENTION:

Wherever couplings may be subject to end thrust forces, they must be secured with grip collars. See p.150 for installation details.

BRANCH CONNECTIONS TO SMALL DIAMETER WASTE PIPES

PAM KONFIX, the easiest solution

The easiest way to connect cast iron systems to other drainage materials is to use rubber connectors or plugs. Flexible couplings and stepping rings are also available to facilitate connections where variances in diameters have to be compensated for.



Rubber transition connectors PAM KONFIX and PAM KONFIX-Multi are used to connect waste pipes made from other materials (steel or plastics) to a PAM cast iron pipe system.



1. Insert the PAM KONFIX rubber connector loosely onto the pipe until the stop point is reached. Then secure to the pipe by tightening the hose clamp screw.

2. Cut the pre-cut rubber to size with a knife and remove the lid. **WARNING:** Do not cut too deep as you may damage the lip seal inside.

3. Mark the insert depth on the connecting pipe. Apply a lubricant and push in. The assembly is complete.

4. The connecting steel pipe illustrated here is only an example. The PAM KONFIX rubber connectors can be used to connect all waste pipe materials to the PAM cast iron systems.

EPDM plugs

The plugs can be pierced to the appropriate groove from 32 mm up to 54 mm waste connections and the center disc torn out where required.

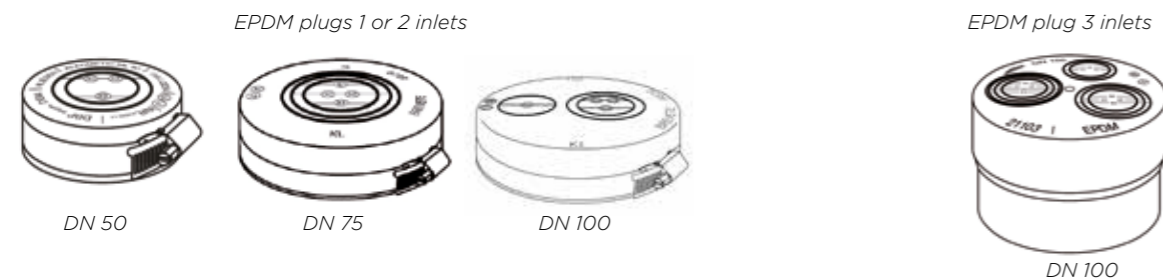

PAM MULTIQUICK, TRANSITION CONNECTOR



To connect PAM cast iron pipes with an outside diameter of 109-112 mm (tolerance range for PAM cast iron pipes DN 100) to other rigid materials with an outside diameter from 72-110 mm. To connect PAM cast iron pipes with an outside diameter of 109-112 mm to waste pipes with an outside diameter up to 115 mm maximum. The connection is made with two hose clamps both suitable to address larger diameter tolerances.



1. Push the open end of the PAM MULTIQUICK connector over the pipe end and place the hose clamp to its tightening position.

2. Then use a knife to cut open the pre-cut lid to the corresponding outside diameter of the connecting waste pipe. Then push the second hose clamp loose over the connecting rubber end.

3. Push the connecting pipe into the PAM MULTIQUICK connector and tighten the hose clamp in the right position. Ensure that the sealing zones (face ends of pipes or fittings) are clean: remove paint flakes and cement residues. The hose clamps should only be tightened manually with a screwdriver to avoid any damage to the PAM MULTIQUICK rubber connector.

CAST IRON TO CAST IRON AND CAST IRON TO OTHER MATERIALS

PAM cast iron connections to other materials may often be required in new construction projects or for renovation. Different solutions can be used with products from our catalog (see figures below). Depending on the outside diameters, solutions exist for compensation. If you are unsure of the circumference of the material being connected, you can use a circumference tape. The range of tolerance of the different joints can help you find the required solution. The table below lists the solutions for connecting PAM cast iron to the most frequently encountered material.

1. PAM Rapid* + Stepping ring (SR)



3. Adapting collar = AC



Max. Pressure 1.5 bar/Stainless steel 304

5. A = B



2. Adapting joint = AJ



Max. Pressure 0.6 bar/
Stainless steel 304

4. Adapting collar (AC) + Stepping ring (SR)



Max. Pressure 1.5 bar /Stainless steel 304

*PAM Rapid can be used for type 1 installation but it may create an aesthetics default (stepping ring can exceed the width of the coupling).

DN*	Existing network material	OD (mm)	Circumference (mm)	Admissible tolerance of couplings (mm)		Coupling type	Product code	Reference diagram
				DE	Perimeter			
50	S Range, Plus range	58	182	55-60	172-188	PAM Rapid S	210424	5
	PVC	50	157	55-60 49-52	172-188 153-163	PAM Rapid S + SR	210424 156399	1
	HDPE	50	157	55-60 49-52	172-188 153-163	PAM Rapid S + SR	210424 156399	1
75	S Range, Plus range	83	260	81-86	254-270	PAM Rapid S	210426	5
	Old cast iron	64	201	81-86 62-65 58-79	254-270 194-204 182-248	PAM Rapid S + SR	210426 156495	1
		77	241	81-86 75-79 58-79	254-270 235-248 182-248	PAM Rapid S + SR	210426 156494	1
		90	282	75-90	235-282	AC	255300	3
	PVC	75	235	81-86 75-79 58-79	254-270 235-248 182-248	PAM Rapid S + SR	210426 156494	1
		80	251	75-79	235-282	AC	255300	3
	HDPE	63	197	81-86 62-65 58-79	254-270 194-204 182-248	PAM Rapid S + SR	210426 156495	1
75		235	81-86 75-79 58-79	254-270 235-248 182-248	PAM Rapid S+ SR	210426 156494	1	

DN*	Existing network material	OD (mm)	Circumference (mm)	Admissible tolerance of couplings (mm)		Coupling type	Product code	Reference diagram	
				DE	Perimeter				
100	S Range, Plus range	110	345	107-112	335-351	PAM Rapid S	210427	5	
	Old cast iron	91	285	107-112 90-93 78-106	335-351 282-292 244-332	PAM Rapid S + SR	210427 156555	1	
		104	326	100-115 78-106	314-361 244-332	AC	155002	3	
		118	370	110-121	345-380	AC	TXB10NP01	3	
	Ductile iron	118	370	110-121	345-380	AC	TXB10NP01	3	
	Fibre cement	115	361	110-121	345-380	AC	TXB10NP01	3	
	PVC	100	314	107-112 99-102 78-106	335-351 310-320 244-332	PAM Rapid S + SR	210427 156635	1	
		110	345	107-112	335-351	PAM Rapid S	210427	5	
	HDPE	90	282	107-112 89-92 78-106	335-351 279-288 244-332	PAM Rapid S + SR	210427 156555	1	
		110	345	107-112	335-351	PAM Rapid S	210427	5	
	Steel	114	358	100-115	314-361	AC	155002	3	
	Sandstone	132	414	110-115 130-145	345-361 408-455	AJ	Contact us	2	
	Concrete	136	427	110-115 130-145	345-361 408-455	AJ	Contact us	2	
	125	S Range, Plus range	135	424	133-138	417-433	PAM Rapid S	210428	5
		Old cast iron	118	370	110-125 121-136	345-387 408-427	AJ	Contact us	2
145			455	130-150	408-471	AC	TXB12NLOG	3	
Ductile iron		144	452	130-150	408-471	AC	TXB12NLOG	3	
Fibre cement		141	442	130-150	408-471	AC	TXB12NLOG	3	
PVC and HDPE		125	392	133-138 123-127	417-433 386-398	PAM Rapid S + SR	210428 156778	1	
Steel		139	436	130-150	408-471	AC	TXB12NLOG	3	
Sandstone	159	499	121-136 144-160	379-427 452-502	AJ	Contact us	2		
150	S Range, Plus range	160	502	158-164	496-514	PAM Rapid S	210429	5	
	Old cast iron	145	455	130-145 155-170 150-175	408-455 486-534 471-549	AJ AC	155003 TXB15NMOJ	2 3	
		172	540	150-175	471-549	AC	TXB15NMOJ	3	
	Ductile iron	170	534	150-175	471-549	AC	TXB15NMOJ	3	
	Fibre cement	166	521	150-175	471-549	AC	TXB15NMOJ	3	
	PVC	140	439	130-145 155-170	408-455 486-534	AJ	155003	2	
		160	502	158-164	496-514	PAM Rapid S	210429	5	
	Steel	168	527	150-175	471-549	AC	TXB15NMOJ	3	
	Sandstone	186	584	144-160 170-193	452-502 533-606	AJ	Contact us	2	
	Concrete	190	596	144-160 170-193	452-502 533-606	AJ	Contact us	2	

CAST IRON TO CAST IRON AND CAST IRON TO OTHER MATERIALS

DN*	Existing network material	OD (mm)	Circumference (mm)	Admissible tolerance of couplings (mm)		Coupling type	Product code	Reference diagram
				DE	Perimeter			
200	S Range, Plus range	210	659	207-213	650-668	PAM Rapid S	210430	5
	Old cast iron	172	540	170-193 210-235	534-606 659-738	AJ	155004	2
		197	618	200-225 192-201	628-706 603-631	AC + SR	TXB20NNOK	4
		218	684	200-225	628-706	AC	TXB20NL0K	3
		225	706					
	Ductile iron	222	697	200-225	628-706	AC	TXB20NL0K	3
	Fibre cement	218	684	200-225	628-706	AC	TXB20NL0K	3
	PVC and HDPE	200	628	207-213 198-202	649-668 621-634	PAM Rapid S + SR	210430 157000	1
	Steel	219	688	200-225	628-706	AC	TXB20NL0K	3
	Sandstone	242	760	204-219 238-254	640-687 747-797	AJ	Contact us	2
	Concrete	244	766	204-219 238-254	640-687 747-797	AJ	Contact us	2
	250	S Range, Plus range	274	860	271-276	850-868	PAM Rapid S	228759
Old cast iron		242	760	240-265 260-285	753-832 816-894	AJ	TXB25NQOK	2
		279	876	260-285	816-894	AC	143192	2
Ductile iron		274	860	271-276	850-868	PAM Rapid S	228759	5
Fibre cement		274	860	271-276	850-868	PAM Rapid S	228759	5
PVC and HDPE		250	785	271-276 248-252	850-868 778-791	PAM Rapid S + SR	228759 157085	1
Steel		273	857	271-276	850-868	PAM Rapid S	228759	5
300	S Range, Plus range	326	1024	323-328	1014-1031	PAM Rapid S	228771	5
	Old cast iron	312	980	310-335	973-1051	AC	TXB30NN02	3
		331	1039	310-335	973-1051	AC	TXB30NN02	3
	Ductile iron	326	1024	323-328	1014-1031	PAM Rapid S	228771	5
	Fibre cement	329	1033	310-335	973-1051	AC	TXB30NN02	3
	PVC and HDPE	315	989	310-335	973-1051	AC	TXB30NN02	3
	Steel	324	1017	323-328	1014-1031	PAM Rapid S	228771	5
	Sandstone	350	1099	320-340 335-360	1005-1068 1051-1130	AC + SR	TXB30NQOM	4
	Concrete	374	1174	310-335 350-375	973-1051 1099-1178	AJ	Contact us	2

MULTI-WASTE MANIFOLD

Manifold Connector

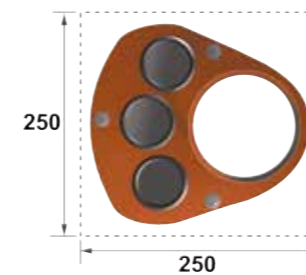

The multi-waste manifold simplifies waste plumbing by grouping all associated pipework from various sources such as sinks, basins, bidets, urinals and showers to one internal point above the finished floor level. The manifold will permit the connection of three 32/38 mm copper/plastic waste inlets to any new or existing 100 mm diameter pipe stack and three 50 mm copper/plastic waste inlets to a 150 mm diameter pipe stack. The manifold main body is connected to the stack using standard coupling. On the 100 mm manifold, to achieve a 32 mm waste connection, remove the 38 mm inner rubber ring by using the outer ring (for waste pipe maximum lengths see EN 12056-2). Pipework connecting discharge appliances to a manifold should be designed not to cause self-siphonage.

Fixing instructions



1. Cut the appropriate groove for 32 mm or 38 mm waste connections (100 mm manifold only), remove the grommet and tear out the centre disk where required.
2. Apply an appropriate silicone grease (not provided) to the outside of the grommet and re-fit into the manifold ensuring the retaining groove of the grommet is located correctly in the casing.
3. Lubricate the pipe ends and insert into the grommet with a rotational movement. Pipe ends may be chamfered for ease of insertion.
4. Any grommet not fitted with a waste pipe must also follow instruction 2 above.

Typical Manifold Application



New multi-waste manifold

Developed to meet the requirements of low waste connections such as walk-in showers or when space is limited.



Benefits:

- > Minimum core holes required saving costs
- > Long tail spigot that can eliminate the need to have a joint in the slab
- > All 6 inlets can be used at the same time.

Features:

- > Available in 100 and 150 mm (see p.106)
- > 6 boss pipes
- > Supplied with 5 blanking plugs
- > Internal baffle to eliminate cross flow
- > Long tail spigot to penetrate the floor slab



BURIED PIPE SYSTEMS

The Plus range pipes can be used in below-ground applications. Buried pipes are subject to mechanical strain due to the weight of the ground and possible wheel loading when laid under an area where traffic circulates.

The mechanical performance of buried pipework is to be considered like a pipe/soil system: the interaction of the pipes with the surrounding soils depends on their stiffness or flexibility, and the type of laying condition selected.

The choice of bedding and backfilling depends on the depth at which the pipes have to be laid, and the size and strength of the pipes. Standard EN 1610 "Construction and testing of drains and sewers" applies to drains normally buried in the ground and normally operating under gravity.

The hypothesis for rigid pipes retained for the calculation of admissible depth of cover is set out below.



DN 100 to DN 300	
Young's modulus:	110,000 N/mm ²
Poisson's ratio:	0.25
Max. stress:	350 N/mm ²
Strain coefficient:	1.5
Buckling coefficient:	2.5
Geometric defect:	1.2 + DN 2,000 mm

Installation parameters are established according to:

- > Soil type (see groups below)
- > Quality of compaction of the embedment
- > Behavior of the pipe (rigid for cast iron)
- > Presence of wheel loads or not
- > Particular conditions (groundwater table, etc.)

Backfilling recommendations from DN 100 to DN 300, with or without traffic loads (according to EN 1610)

Two main solutions have been retained from the EN 1610 recommendations, taking into account both ease of installation and knowledge from experience of rigid pipe systems. For compaction, the most adverse hypothesis was retained.

These solutions maximise the advantage obtained from cast iron's mechanical properties: depth of cover it can withstand, possible backfilling with native soil removed, thereby limiting damage to the environment, etc.

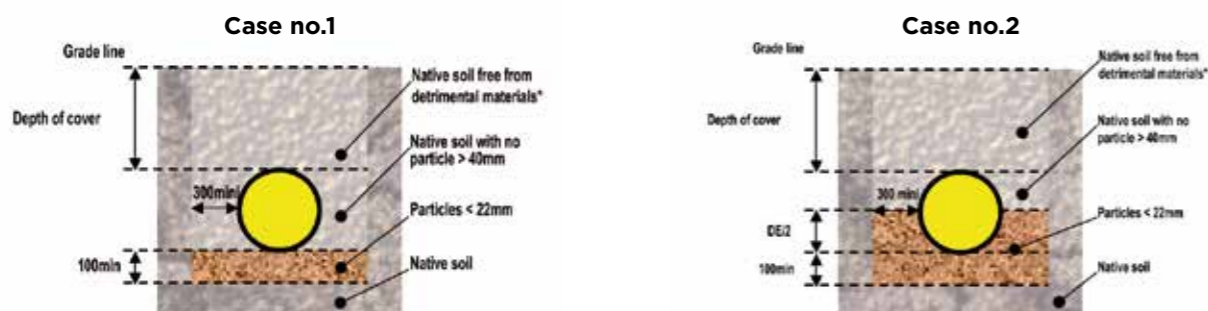

Dimensions are in mm

* Detrimental materials = stones, tree roots, rubbish, organic material, clay lumps (>75 mm), snow and ice.

Based on our experience in buried pipe systems and the French origin of our company, we have applied the French Fascicule 70 calculation model (recommendations for sewage pipe systems according to the pipe material).

The table below gives values for depths of cover according to the Fascicule 70 calculation, considering rigid pipes.



		Depth of cover values (m)	
		Without traffic loads	With traffic loads
Solution 1	Min.**	0.3(1)	1
	Max.	3.2	2.4
Solution 2	Min.**	0.3(1)	0.3
	Max.	6 (or 9)	6 (or 9)

** Does not take into account the frost-free arrangements.

(1) The calculation allows shallower depth of cover, but this figure includes a safety margin / ground surface proximity and related hazards.

Other precautions

- > Clearance at each joint between the couplings and the granular bed to allow sufficient space, and to prevent the pipe from resting on the joints. (see EN 1610 §8.5.4)
- > Testing for pipe system leak tightness according to EN 1610 §13.
- > Identification of the pipework with a netting for example.
- > Furthermore, check that these specifications do not contravene other local or national regulations or recommendations for installation.

For any other case, other diameters or buried systems under the bottom slab, please contact our technical support team: tcbatiment.sgpam@saint-gobain.com

Where the pipe system is to be set in concrete, a minimum 2.5 cm width of concrete on every side has to be respected because during and after its curing, the concrete will be subject to shrinkage and carbonation.

To reduce the natural rigidity of the concrete and its strain, a suitable flexible joint can be installed at intervals. This could be made of a compressible material (e.g. expanded polystyrene), be placed next to a pipe joint, and conform to the full cross section of the concrete. (See Fig). Refer to local best practice.

Furthermore, the pipe system should not be in contact with the concrete's metal reinforcements.

Surround should not be carried out until the pipework has been tested and inspected.

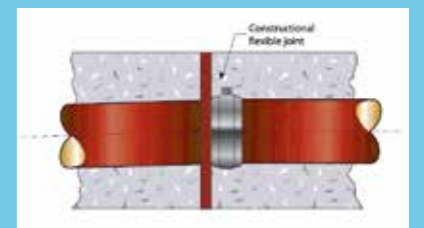



The EPAMS® system is a combination of cast iron pipes, fittings and accessories, jointed with PAM couplings able to withstand a negative pressure of -900 mbar.

The system is under French Technical Approval 5+14/14-2386 CSTB.

EXPLANATIONS OF SIPHONIC SYSTEMS

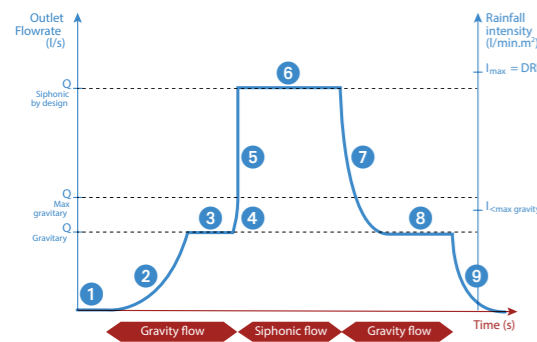

1. No rain
2. Rainfall starts at low intensity – Drainage is performed by gravity flow
3. Continuous flow is achieved according to the rainfall intensity and roof area drained
4. Rainfall intensity increases to the maximum DRI – Flow continues by gravity until the maximum value is reached
5. No more air entering the system – Kinetic and pressure energies enhance the absorbing capacity quickly to the maximum design flow rate
6. Rainfall intensity stabilises to max. value => absorbing siphonic flow rate is maintained
7. Rainfall intensity decreases – Flow comes back to gravity system
8. Rainfall intensity stabilises to low value => absorbing gravity flow rate is maintained
9. No more rain – the rooftop surface is emptying

EPAMS® DESIGN SERVICE

A siphonic roof drainage system is truly an “engineered system” which must be designed with careful and expert analysis. The pipework design is the key factor for performance and operational safety.

PAM Building sales staff, trained in the EPAMS® system, first evaluate your roof drainage project. When feasibility is confirmed, a technical team designs both the technical study and network sizing using the dedicated EPAMS® software.

The system must always be properly balanced and the flow velocity controlled. To protect the lifespan of the EPAMS® siphonic systems, the PAM Building design maintains that the dynamic pressure within the system should never exceed 5 bar.

Trained staff specifically in charge of your design will handle your siphonic project until the work’s acceptance; each change to the plans results in the need for a new study.

Before the acceptance of the work, PAM Building or a delegated third party checks on site that the installation fully complies with the last study isometric drawings; any modification to an EPAMS® pipework route at the installation stage requires further approval from PAM Building.

This thorough management of the EPAMS® projects – feasibility study, project follow-up and control after installation completion – ensures the EPAMS® system’s efficiency and provides the project manager with total peace of mind.



EPAMS® 100% METAL OUTLETS

The EPAMS® outlets are made of 3 different parts:

- > The Anti-Vortex mechanism, aluminium grating. Bolted on the bowl, it is the same for all the outlets.
- > An identical stainless steel bowl for all the outlets, on which different components can be assembled depending on the field of use.
- > A stainless steel tail available in four DN: 50 - 75 - 100 - 125.

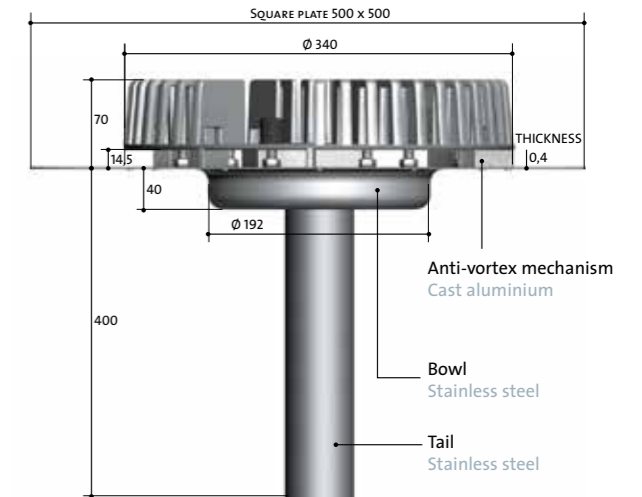

INSTALLATION

The EPAMS® outlets are easy to install. The installation has to be done in accordance with best practice and the Technical Approval requirements.

PAM Building EPAMS® 100% metal outlets fully guarantee mechanical strength and durability. They fully comply with EN 1253 on each specific point: flow capacity, watertightness, solidity, mechanical strength, heat resistance and climatic stresses (resistance to UV radiation).

The grating and anti-vortex mechanism are made in one piece. This allows quick removal with no risk of mistakes at reassembly, easy intervention and maintenance.

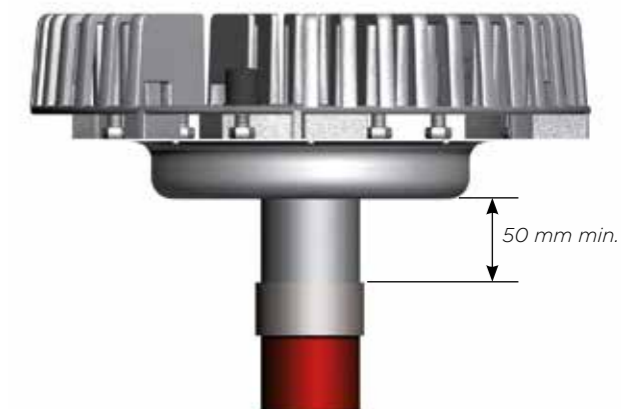

EPAMS® siphonic roof drainage pipework

An EPAMS® pipework consists of one or several horizontal pipes without fall connected to a downpipe: horizontal runs and stacks are made of S range cast iron components. The joints are generally made with PAM Rapid or equivalent couplings.

> Connection of the roof outlets to the pipe system:

Depending on the job site constraints, the connection can be made flat or vertical.

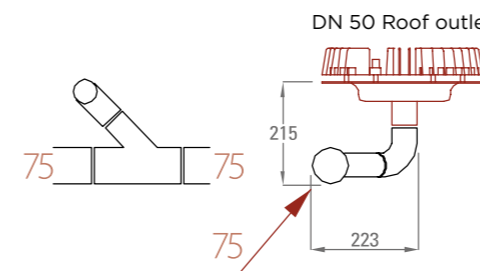

Minimum dimension flat branching

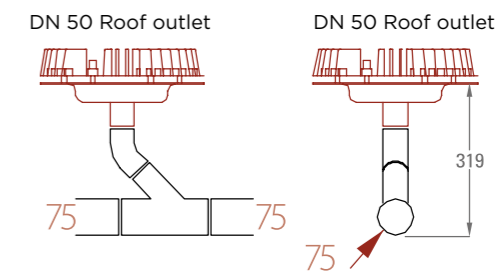

Minimum dimension vertical branching

> Decompression zone:

Before connecting to the sewer main, siphonic systems have to run by gravity again.

At the end of the downpipe, the bottom pipe increases in diameter – generally two extra diameters – causing decompression and reducing the flow velocity.

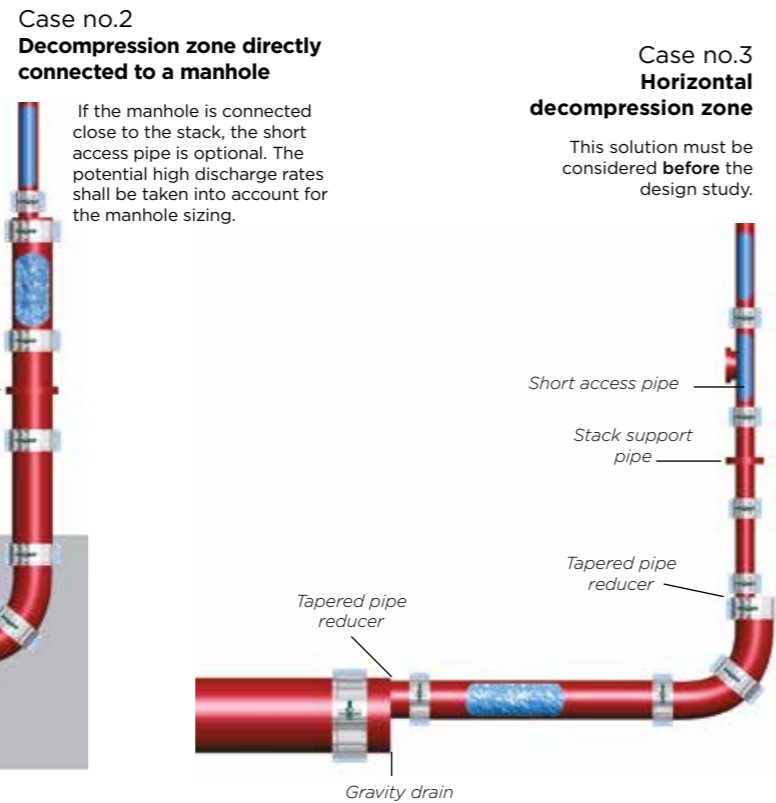
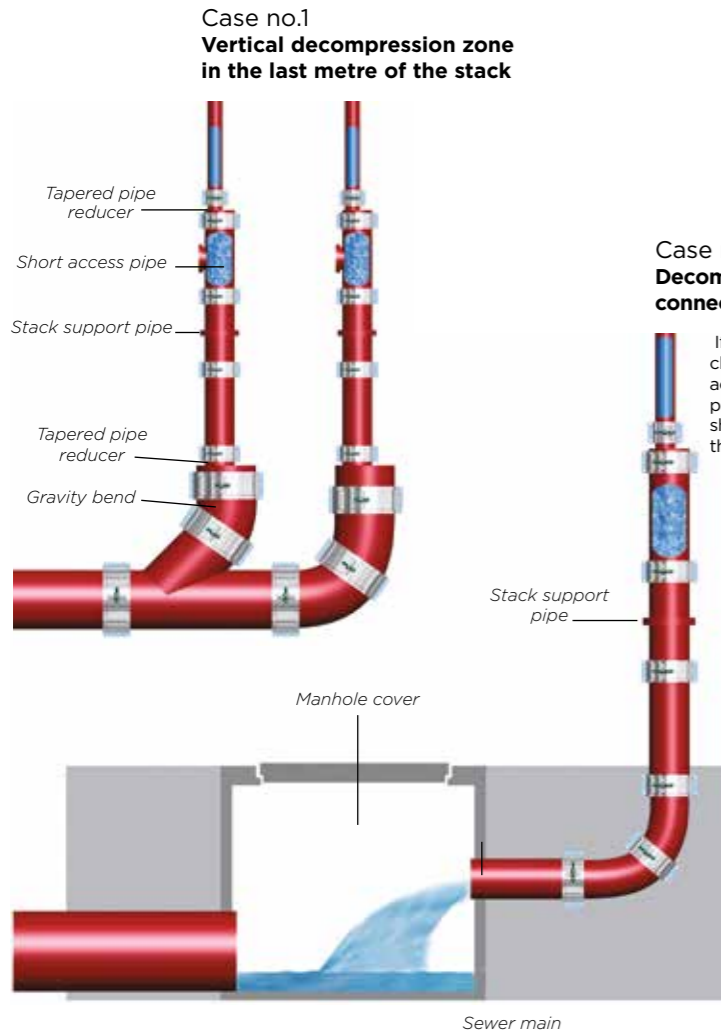

> Pipe support

Stack support pipes are installed at the bottom of stacks to address forces due to changes in the stream flow systems.

Every 15 metres is the general requirement.



> Pipe brackets

Owing to the high discharge rates, rubber-lined steel brackets are compulsory. Two brackets per pipe length shall be installed for horizontal or vertical pipework. It is also recommended to use one bracket per length or fitting (when the shape allows it, i.e. branches, etc.).

For the EPAMS® siphonic system, only round full and rubber-lined brackets shall be used.

For brackets fixed to plain threaded rods, the distance between the bearing structure (concrete slab, steel frame, etc.) and the axis of the pipe shall not exceed 500 mm. If this maximum distance cannot be respected, the rigidity of the fixings should be increased (triangulation, steel knee brace).

Check local requirements for compliance.

Specific points of the network

> Gripped couplings

On EPAMS pipework, grips collars are specified on couplings where they will withstand dislocation forces.

- Horizontal pipe connected to the outlet when the expected pressure is over 0.5 bar or -0.5 bar.
- The negative pressure will be highest at the head of the stack (down to -0.9 bar); the couplings there will be systematically installed with grip collars.
- Change of direction: at changes of direction on stacks and low collectors, the couplings will be gripped. Where a change of direction will be added or removed, PAM Building will carry out a new study taking the new head loss into account.



- The decompression zone is subject to turbulences, and subsequently, every component at the bottom of the stack, before the return to the gravity flow system, will be gripped.

		Number of brackets
Vertical run	Pipes	2
	Fittings*	1
Horizontal run	Pipe length > 2 m	2
	Pipe length < 2 m Fittings*	1

* When the shape of the fitting permits

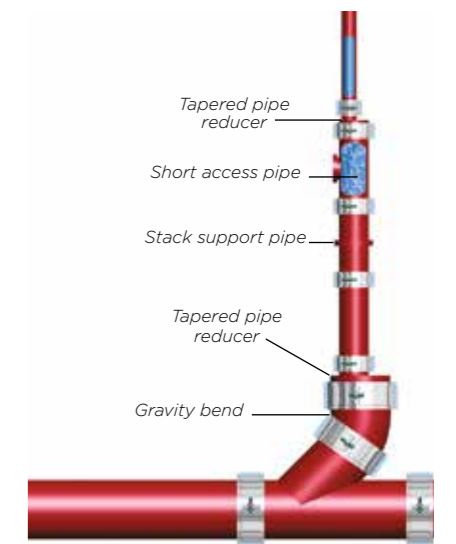

> Reduction of flow sections

Achieving balance of potential energy and head losses on the pipework can require a reduction in the nominal diameters to increase head losses.

The regulations state that reducing the nominal diameter (DN) of discharge pipes is prohibited in the direction of flow except for siphonic systems like EPAMS® (EN 12056-3 § 7,6,5) where it could be useful to control the pressure level. Increases and reductions of nominal diameters are made with the tapered pipe reducer. On horizontal runs, the pipe reducer will be installed so that the pipe invert is continuous.

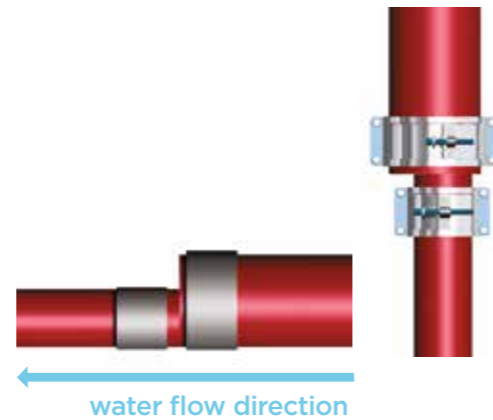

MAINTENANCE GENERAL FEATURES

Keeping the roof outlets clean is key to keeping an EPAMS® siphonic system in good working order.

The Technical Approval recommends they should be cleaned at least twice a year.

Any element like plant matter (leaves, twigs, etc.) or debris from the surroundings can end up on rooftops, and must be regularly cleared away to prevent clogging of the pipework or EPAMS® outlets. Maintenance cleaning frequency will largely depend on the building's environment. For buildings surrounded by trees and gardens, inspections will be done more frequently and the maintenance rate will be higher than the standard twice yearly requirement.

For all types of roof outlets, the cleaning process must be carried out as described opposite.



Ensure the leafguard grid is in place. Clean the leafguard grid.



Remove the nut caps.



Unscrew the nuts and lift the leafguard grid to remove it.



Clean the inside of the roof outlet bowl.

INSTALLATION FEATURES

Preparation

Cast iron pipe systems for drainage mainly consist of spigot pipes - generally supplied in 3 m lengths - and fittings of various shapes (bends, branches, etc.). The cast iron pipes can be cut to length. Where pipes are cut on site, ends shall be cut clean and square with burrs removed, and then re-coated with the adequate EXTREM 1 touch-up paints (see p.145), or other repair products recommended by PAM Building.

RECOMMENDED TOOLS



Extrem 1 Touch-up paint



Cordless Drill



A - T-Box Spanner
B - 13 mm Deep Socket
C - Allen Key Socket Adapter
D - Ratchet Spanner

RECOMMENDED TO CUT THE PIPE



Exact saw





Chop saw

For more information contact the technical department by e-mail: tcbatiment.sgpam@saint-gobain.com

Cutting techniques

Pipes can be cut easily and quickly using either of the following methods. Cutting procedures must comply with the safety guidelines provided in the cutting tool manufacturer's operating manual.

			
	Pipe cutter	Exact saw	Powered disc cutter
S and Plus ranges			
DN50			
DN75			
DN100			
DN125			
DN150			
DN200			
DN250			
DN300			
DN400			
DN500			
DN600			
FLUTED RAINWATER RANGE			
DN75			
DN100			

The Exact saw : the ultimate and fast solution for cutting 50-200 mm cast iron (see p.145)

- Easy, secure and effortless cutting for use on construction sites
- Wide range of applications and dimensions
- No rework necessary - accurate cutting
- Suitable for clamping joints
- Reduction in tool costs
- Reduction in sparks - may not require hot works permit



Coating cut ends

Pipe ends needed to be re-coated with touch-up paint.

We recommend protecting the cut ends with the same standard as the pipe's internal coating: in this instance, you can use EXTREM 1 (see p.145), a new quick drying touch-up paint that air dries in 15 minutes.



Overpainting method

The acrylic paint on the pipes is a primer which can be over painted with most top coats. Finishing paint is needed where the pipework is visible, indoor or outdoor. What types of paint can be used? Any alkyd resin or glycerophthalic paint designed for metal care and suitable for the requirements of the local environment.

The system should be gently rubbed down with suitable abrasive paper to provide a good adhesion key for the finishing coating. Where the finishing paint is to be used on zinc-coated pipes to rejuvenate them, rub them down gently to remove possible zinc salts.

Where incipient rust has already appeared on cast iron products, corrosion inhibitors can be used before painting. Some existing metal finishes, including anti-corrosive pigment, can be applied directly to rust.

MODIFICATIONS TO AN EXISTING INSTALLATION

Typical example of a spigot system

1. Measure the length of the branch, adding a further 15 mm in total to allow for the coupling's central register top and bottom.
2. Make sure existing pipework is adequately supported from above.
3. Mark the pipe position for cutting.
4. Cut the pipe using a powered disc cutter or wheel cutter and remove sharp edges.
5. Coat the cut ends with the appropriate touch-up product (epoxy coating).
6. Push the rubber gaskets onto the spigot cut ends top and bottom, ensuring the central registers are abutted against each spigot edge.
7. Position the fitting in the stack within each rubber gasket abutting against the central registers.
8. Loosely assemble the coupling around each gasket.
9. Check alignment of assembly before tightening the bolts to the recommended level, depending on the coupling's technical recommendations.
10. Test the new stack for successful joints.



$X = \text{fitting} + 15 \text{ mm}$

APPLICATION

For the dimensioning of rainwater and wastewater systems, the nominal sizes can be determined using the dimensioning tables in the appendix of DIN EN 12056. These tables only represent the discharge capacity of the smallest permissible inner diameter of the values specified.

If the pipe material is known at the latest during the execution planning, the specific discharge capacities should be determined for a differentiated calculation on the basis of the actual internal diameter of the respective drainage pipe system should be used for a differentiated calculation.

EXAMPLE OF WASTEWATER PIPE FILLING LEVEL $H/D = 1.0$ WITH SLOPE 1 CM

DN	PAM drainage pipes	DIN 1986-100, A3	DIFFERENCE
100	3,0 l/s	2,5 l/s	+20%
125	5,3 l/s	3,9 l/s	+36%
150	8,5 l/s	7,7 l/s	+10%

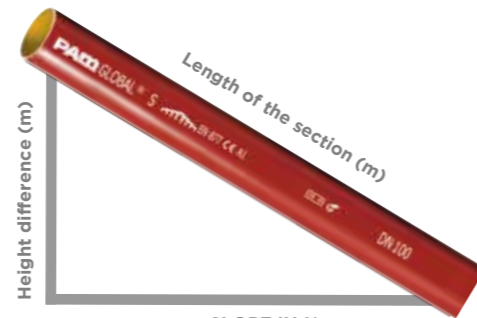

SLOPE IN % = $\frac{\text{HEIGHT DIFFERENCE}}{\text{LENGTH OF THE TRACK}} \cdot 100$

Filling level 70% ($h/d_i=0.7$)

J cm/m	DN 75 $d_i = 75$		DN 100 $d_i = 103$		DN 125 $d_i = 127$		DN 150 $d_i = 152$		DN 200 $d_i = 200$		DN 250 $d_i = 263$		DN 300 $d_i = 314$	
	Q l/s	v m/s	Q l/s	v m/s	Q l/s	v m/s	Q l/s	v m/s	Q l/s	v m/s	Q l/s	v m/s	Q l/s	v m/s
0.5	1.5	0.5	3.6	0.6	6.2	0.7	10.1	0.7	20.8	0.9	43.1	1.1	68.9	1.2
0.6	1.7	0.5	3.9	0.6	6.8	0.7	11.0	0.8	22.9	1.0	47.2	1.2	75.5	1.3
0.7	1.8	0.5	4.2	0.7	7.4	0.8	11.9	0.9	24.7	1.1	51.1	1.3	81.6	1.4
0.8	1.9	0.6	4.5	0.7	7.9	0.8	12.7	0.9	26.4	1.1	54.6	1.3	87.3	1.5
0.9	2.1	0.6	4.8	0.8	8.4	0.9	13.5	1.0	28.0	1.2	58.0	1.4	92.6	1.6
1.0	2.2	0.7	5.1	0.8	8.8	0.9	14.3	1.1	29.6	1.3	61.1	1.5	97.6	1.7
1.1	2.3	0.7	5.3	0.9	9.3	1.0	15.0	1.1	31.0	1.3	64.1	1.6	102.4	1.8
1.2	2.4	0.7	5.5	0.9	9.7	1.0	15.6	1.2	32.4	1.4	67.0	1.6	107.0	1.8
1.3	2.5	0.7	5.8	0.9	10.1	1.1	16.3	1.2	33.8	1.4	69.7	1.7	111.4	1.9
1.4	2.6	0.8	6.0	1.0	10.5	1.1	16.9	1.2	35.0	1.5	72.4	1.8	115.6	2.0
1.5	2.7	0.8	6.2	1.0	10.9	1.1	17.5	1.3	36.3	1.5	74.9	1.8	119.7	2.1
1.6	2.7	0.8	6.4	1.0	11.2	1.2	18.1	1.3	37.5	1.6	77.4	1.9	123.7	2.1
1.7	2.8	0.9	6.6	1.1	11.6	1.2	18.6	1.4	38.6	1.6	79.8	2.0	127.5	2.2
1.8	2.9	0.9	6.8	1.1	11.9	1.3	19.2	1.4	39.8	1.7	82.1	2.0	131.2	2.3
1.9	3.0	0.9	7.0	1.1	12.2	1.3	19.7	1.5	40.9	1.7	84.4	2.1	134.8	2.3
2.0	3.1	0.9	7.2	1.2	12.5	1.3	20.2	1.5	41.9	1.8	86.6	2.1	138.3	2.4
2.5	3.4	1.0	8.0	1.3	14.0	1.5	22.6	1.7	46.9	2.0	96.9	2.4	154.7	2.7
3.0	3.8	1.1	8.8	1.4	15.4	1.6	24.8	1.8	51.4	2.2	106.1	2.6	169.6	2.9

DISCHARGE CAPACITY OF PAM PIPES ACCORDING TO EN 877 AND DIN 19522

Filling level 50% ($h/d_i=0.5$)

J cm/m	DN 75 $d_i = 75$		DN 100 $d_i = 103$		DN 125 $d_i = 127$		DN 150 $d_i = 152$		DN 200 $d_i = 200$		DN 250 $d_i = 263$		DN 300 $d_i = 314$	
	Q l/s	v m/s	Q l/s	v m/s	Q l/s	v m/s	Q l/s	v m/s	Q l/s	v m/s	Q l/s	v m/s	Q l/s	v m/s
0.5	0.9	0.4	2.1	0.5	3.7	0.6	6.0	0.7	12.5	0.8	25.8	1.0	41.3	1.1
0.6	1.0	0.4	2.3	0.6	4.1	0.6	6.6	0.7	13.7	0.9	28.3	1.0	45.3	1.2
0.7	1.1	0.5	2.5	0.6	4.4	0.7	7.1	0.8	14.8	0.9	30.6	1.1	48.9	1.3
0.8	1.1	0.5	2.7	0.6	4.7	0.7	7.6	0.8	15.8	1.0	32.7	1.2	52.3	1.4
0.9	1.2	0.6	2.9	0.7	5.0	0.8	8.1	0.9	16.8	1.1	34.7	1.3	55.5	1.4
1.0	1.3	0.6	3.0	0.7	5.3	0.8	8.5	0.9	17.7	1.1	36.6	1.3	58.5	1.5
1.1	1.4	0.6	3.2	0.8	5.5	0.9	8.9	1.0	18.6	1.2	38.4	1.4	61.4	1.6
1.2	1.4	0.6	3.3	0.8	5.8	0.9	9.4	1.0	19.4	1.2	40.1	1.5	64.2	1.7
1.3	1.5	0.7	3.4	0.8	6.0	1.0	9.7	1.1	20.2	1.3	41.8	1.5	66.8	1.7
1.4	1.5	0.7	3.6	0.9	6.3	1.0	10.1	1.1	21.0	1.3	43.4	1.6	69.3	1.8
1.5	1.6	0.7	3.7	0.9	6.5	1.0	10.5	1.2	21.7	1.4	44.9	1.7	71.8	1.9
1.6	1.6	0.7	3.8	0.9	6.7	1.1	10.8	1.2	22.4	1.4	46.4	1.7	74.1	1.9
1.7	1.7	0.8	3.9	0.9	6.9	1.1	11.1	1.2	23.1	1.5	47.8	1.8	76.4	2.0
1.8	1.7	0.8	4.1	1.0	7.1	1.1	11.5	1.3	23.8	1.5	49.2	1.8	78.7	2.0
1.9	1.8	0.8	4.2	1.0	7.3	1.2	11.8	1.3	24.5	1.6	50.6	1.9	80.8	2.1
2.0	1.8	0.8	4.3	1.0	7.5	1.2	12.1	1.3	25.1	1.6	51.6	1.9	82.9	2.1
2.5	2.0	0.9	4.8	1.2	8.4	1.3	13.5	1.5	28.1	1.8	58.0	2.1	92.8	2.4
3.0	2.2	1.0	5.3	1.3	9.2	1.5	14.8	1.6	30.8	2.0	63.6	2.3	101.7	2.6

Filling level 100% ($h/d_i=1.0$)

J cm/m	DN 75 $d_i = 75$		DN 100 $d_i = 103$		DN 125 $d_i = 127$		DN 150 $d_i = 152$		DN 200 $d_i = 200$		DN 250 $d_i = 263$		DN 300 $d_i = 314$	
	Q l/s	v m/s	Q l/s	v m/s	Q l/s	v m/s	Q l/s	v m/s	Q l/s	v m/s	Q l/s	v m/s	Q l/s	v m/s
0.5	1.8	0.4	4.2	0.5	7.4	0.6	12.0	0.7	24.9	0.8	51.6	1.0	82.6	1.1
0.6	2.0	0.4	4.7	0.6	8.2	0.6	13.2	0.7	27.4	0.9	56.6	1.0	90.5	1.2
0.7	2.1	0.5	5.0	0.6	8.8	0.7	14.2	0.8	29.6	0.9	61.2	1.1	97.8	1.3
0.8	2.3	0.5	5.4	0.6	9.4	0.7	15.2	0.8	31.6	1.0	65.4	1.2	104.6	1.4
0.9	2.4	0.6	5.7	0.7	10.0	0.8	16.2	0.9	33.6	1.1	69.4	1.3	111.0	1.4
1.0	2.6	0.6	6.0	0.7	10.6	0.8	17.1	0.9	35.4	1.1	73.2	1.3	117.1	1.5
1.1	2.7	0.6	6.3	0.8	11.1	0.9	17.9	1.0	37.1	1.2	76.8	1.4	122.8	1.6
1.2	2.8	0.6	6.6	0.8	11.6	0.9	18.7	1.0	38.8	1.2	80.3	1.5	128.3	1.7
1.3	2.9	0.7	6.9	0.8	12.1	1.0	19.5	1.1	40.4	1.3	83.6	1.5	133.6	1.7
1.4	3.1	0.7	7.2	0.9	12.5	1.0	20.2	1.1	41.9	1.3	86.7	1.6	138.7	1.8
1.5	3.2	0.7	7.4	0.9	13.0	1.0	20.9	1.2	43.4	1.4	89.8	1.7	143.6	1.9
1.6	3.3	0.7	7.7	0.9	13.4	1.1	21.6	1.2	44.9	1.4	92.8	1.7	148.3	1.9
1.7	3.4	0.8	7.9	0.9	13.8	1.1	22.3	1.2	46.3	1.5	95.6	1.8	152.9	2.0
1.8	3.5	0.8	8.1	1.0	14.2	1.1	22.9	1.3	47.6	1.5	98.4	1.8	157.3	2.0
1.9	3.6	0.8	8.3	1.0	14.6	1.2	23.6	1.3	48.9	1.6	101.1	1.9	161.7	2.1
2.0	3.7	0.8	8.6	1.0	15.0	1.2	24.2	1.3	50.2	1.6	103.8	1.9	165.9	2.1
2.5	4.1	0.9	9.6	1.2	16.8	1.3	27.1	1.5	56.2	1.8	116.1	2.1	185.6	2.4
3.0	4.5	1.0	10.5	1.3	18.4	1.5	29.7	1.6	61.6	2.0	127.2	2.3	203.3	2.6

d_i = INTERNAL DIAMETER J = GRADIENT Q = VOLUME FLOW RATE V = FLOW VELOCITY

07

GENERAL TERMS & CONDITIONS OF SALE

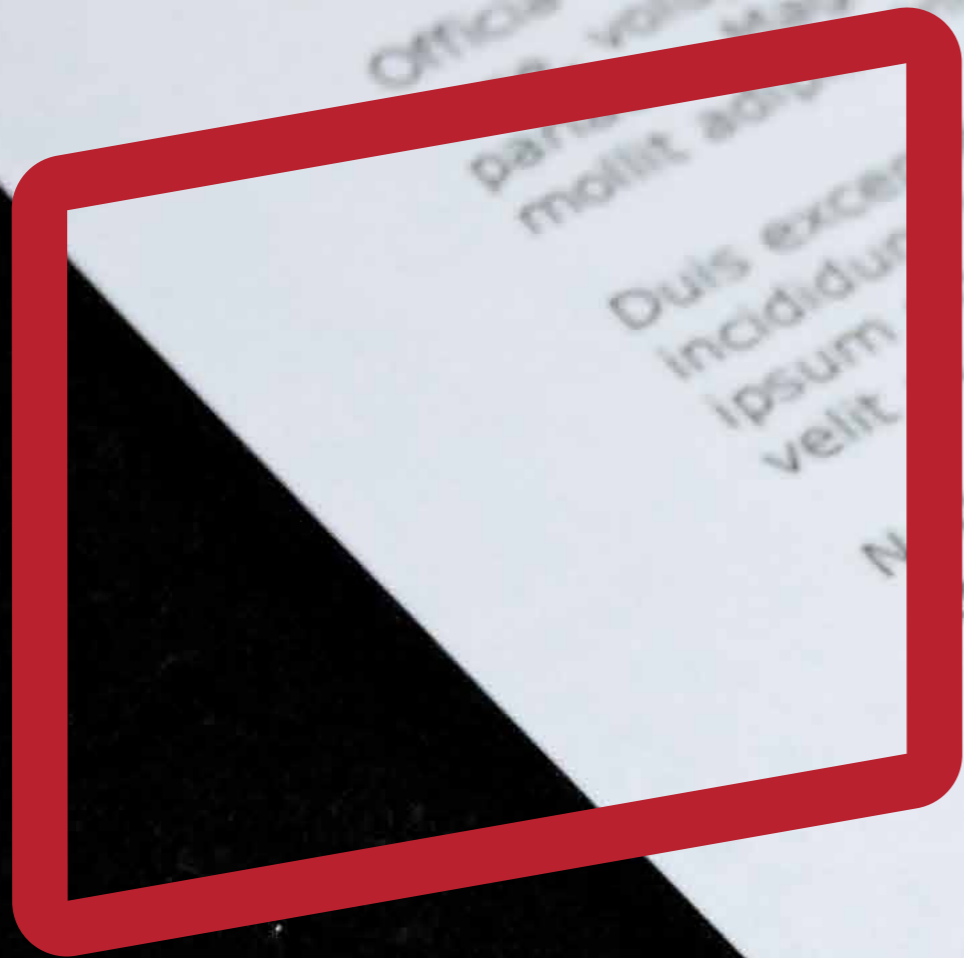

Article 1 - GENERAL PROVISIONS

These Terms and Conditions of Sale ("T&Cs") cancel and replace those previously communicated. They apply to any order placed by a client ("Client") to SAINT-GOBAIN PAM BÂTIMENT, a company organized and existing under the laws of the French Republic with a share capital of 6 812 970,75 € with its registered office at 21 avenue Camille Cavallier in Pont-à-Mousson (54700), France registered with the Register of Commerce of Nancy under number 799 283 882 ("SG PAM BAT"), for the sale of SG PAM BAT's goods and services ("Products").

Any order made by the Client implies its adherence to these terms and conditions of sale. The Client's purchasing conditions shall not take precedence over these terms and conditions of sale unless first agreed in writing by SG PAM BAT.

SG PAM BAT reserves the right to amend its T&Cs at any time, the applicable T&Cs being those in force on the date of the order sent by the Buyer.

Article 2 - ORDERS - ACCEPTANCE

2.1 - Each order for Products must be identified as an order and must include the necessary information for its processing, in particular sufficient accurate information on the branding, delivery and listing of the range, in order to allow SG PAM BAT to process this order as best possible. In case of insufficient or inaccurate information, SG PAM BAT may delay the shipping date of Products, without prejudice to any other solution.

2.2 - Orders do not become firm and final until SG PAM BAT has issued an acknowledgement of receipt. No modification or cancellation of an order shall be taken into account after the issue of the acknowledgement of receipt of the order. Unless otherwise provided between the parties, SG PAM BAT's silence does not constitute acceptance of an order.

Article 3 - PRICING

3.1 Products are sold under the conditions and for the prices currently applicable on the effective delivery date or, where there is an offer, the prices indicated in relation to it, insofar as the order is received by SG PAM BAT within the period of validity of that offer.

3.2 Where SG PAM BAT issues an offer, prices are firm throughout the duration of the offer or for a maximum duration of two (2) months following the issue date of that offer. After this period, price increases may be applied.

3.3 Prices may be modified by SG PAM BAT at any time with a notice period of thirty (30) days.

3.4 Unless specifically agreed, prices are expressed in euros, net, excluding VAT. If applicable according to the Products destination, these prices are billed

after application of value added tax at the rate in force. SG PAM BAT shall be entitled to recover any tax, duty or increase arising from a change to regulations or legislation, from its entry into force.

Article 4 - DELIVERY

4.1 Our delivery times are mentioned as an indication, and correspond to our best estimate. Delivery times are only firm when they are expressly classified as such in the order acknowledgement.

4.2 Non-respect of the indications relative to the delivery time does not authorise the Client to cancel their order, to delay payment beyond the agreed conditions or to withhold or offset any part of it.

4.3 No late penalty may be claimed from SG PAM BAT if it has not been expressly agreed with regard to its principle and its terms in the order acknowledgement.

4.4 SG PAM BAT is not responsible for breached delivery times where:

- > the Client has not respected the payment conditions; or
- > where information to be provided by the Client has not arrived within the required time;

4.5 The transfer of ownership of the Products to the Client is conditional upon payment of the price in full.

4.6 Risk is transferred under the conditions defined by the chosen Incoterm (Incoterms published by Paris International Chamber of Commerce in force on the effective delivery date, the "Incoterms") or where Products are customised and covered by the carrier.

4.7 In the absence of specific conditions agreed beforehand and confirmed in the order acknowledgement by SG PAM BAT, the Products are sold Free Carrier (FCA - Incoterms® 2020) from SG PAM BAT's shipping site.

4.8 For any exit from the European Union territory made by the Client or the forwarding agent designated by the Client, as proof of exit, the Export Control System ("ECS") of exit must be sent to SG PAM BAT. In the event that the ECS cannot be provided, the Client or its forwarding agent may send to SG PAM BAT, the Bill of lading for shipment by sea or the Airway Bill for shipment by air or the CMR Way Bill with receiver's signature and stamp or the Delivery note with receiver's signature and stamp.

Article 5 - INSPECTION

5.1 Products are inspected in the factory according to SG PAM BAT's quality control procedures and the standards in force.

5.2 In cases where a special inspection has been agreed, by the Client or an organisation representing it, the inspectors in charge are advised

of the dates and times in which inspections must normally take place.

Article 6 - TRANSPORT

6.1 Where the Client organises transport itself, it assumes the restrictions of adapting vehicles to Products and the obligation to make an appointment 48 hours in advance. Otherwise, the delivery cannot be loaded.

6.2 The Client is responsible for unloading operations carried out under its control. In this regard, the Client must ensure respect for safety conditions on site and provide suitable means to allow unloading in the best possible safety conditions. In particular, in case of a delivery by truck crane, the Client shall assist the driver by separating pipes and packages on the ground. The Client must establish a safety protocol with the carrier prior to unloading.

6.3 In case of lost, damaged or missing Products observed upon delivery, the Client shall take recourse against the carrier, stating its reservations on the transporter's delivery form. It will confirm these reservations with the carrier, by registered letter with acknowledgement of receipt, addressing its claim with supporting documentation within 3 business days following receipt of the Products.

Article 7 - PAYMENT CONDITIONS

7.1 Unless otherwise indicated, payments are made at the address stated on the invoice, within forty-five (45) days from end of the month following the invoice issue date, independently from the date of receipt of the Products by the Client.

7.2 Drafts accepted must be returned within 10 days following their issuance. This deadline also applies to means of payment issued by the Client.

7.3 Any payment made after the payment date stated on the invoice shall allow the billing of (i) late penalties at a rate equal to the interest rate applied by the European Central Bank to its refinancing operation plus 10 percentage points and (ii) a fixed charge for recovery costs, of a sum of €40; SG PAM BAT reserves the right to seek additional compensation, upon justification, in the event that its recovery costs exceed this amount.

7.4 In case of non-payment of an outstanding invoice, all of the invoices in arrears shall become immediately payable. In addition, SG PAM BAT reserves the right to suspend orders in progress, without prejudice to damages and interest.

7.5 No claim by the Client may invoke the modification, delay or suspension of payments due, or authorise it to offset or deduct payments against those owed to SG PAM BAT. Any offsetting or deduction not agreed beforehand shall constitute a payment incident justifying the application of the

above measures.

7.6 In the event of a significant change to the Client's legal or financial situation, affecting SG PAM BAT's assessment of its solvency, or in case of an excessive outstanding amount, SG PAM BAT reserves the right even after partial execution of an order to either demand guarantees or cancel the outstanding orders.

Article 8 - GUARANTEE FOR PRODUCTS

8.1 Without prejudice to the measures to be taken with regard to the carrier, claims in relation to the non-conformity of delivered Products with those listed on the order acknowledgement must be submitted in writing within 3 days from receipt of the Products. After this time, no claims shall be accepted.

8.2 SG PAM BAT guarantees the Client against hidden defects that may affect the sold Products. If the Client detects a manufacturing fault in the Product, in its opinion constituting a hidden defect, it must send a claim to SG PAM BAT immediately.

8.3 The implementation of the guarantee for conformity and hidden defect is conditional upon these faults being jointly observed and acknowledged as effectively attributable to SG PAM BAT. The Client will provide all justifications as to the reality of the faults found. It shall facilitate SG PAM BAT in observing these faults and remedying them. The Client shall abstain from interfering with the Products.

8.4 An observation of the fault will then be conducted, within 1 month -with everything as is, except in case of force majeure - in a report in the presence of SG PAM BAT's representatives.

8.5 If the existence of a fault is jointly found and recognised by SG PAM BAT as being effectively attributable to it, SG PAM BAT shall assume the repair of the Product or supply a replacement of the Product previously delivered, and the corresponding shipping costs.

8.6 The Client is obliged under its exclusive responsibility to respect the indications given by SG PAM BAT as well as the industry standards for the compliant handling and use of the Products as well as all technical instructions.

8.7 The guarantee given is excluded in case of:

- > apparent defect, or that which a professional would discover;
- > defect and/or deteriorations caused by natural wear or by an external accident;
- > modification of the Product not provided for or specified by SG PAM BAT;
- > defect and/or deteriorations caused by a compatibility fault against Products not provided

by SG PAM BAT;

> non-respect by the Client of the indications concerning handling, fitting, use and maintenance of Products as well as industry standards;

> force majeure or similar event.

8.8 The guarantee given by SG PAM BAT is for 12 months from delivery. Interventions conducted in relation to the guarantee shall not result in extending this period.

ARTICLE 9 - LIABILITY

9.1 SG PAM BAT warrants that its Products comply with their specifications at the date at which they are placed at Client's disposal. Specifications, performances and technical characteristics stated in catalogs, technical brochures and any other commercial documentation and packaging are subject to revision at any time without any prior notice to the Client. Characteristics and colours of SG PAM BAT's Products have an indicative value due to their nature of manufacturing.

9.2 Client recognizes that he is aware of the technical characteristics of the Products as well as their conditions of use and application, defined in particular by the rules of the art and the current technical documentations. For the avoidance of doubt, the Client shall conduct prior and sufficient tests to verify that the Products meet its requirements.

9.3 SG PAM BAT's liability is limited to the supply of the Products complying with SG PAM BAT's specifications to the exclusion of any consequence of an improper, careless or inadequate use which remains under the exclusive responsibility and liability of the Client.

9.4 SG PAM BAT's liability is limited to the replacement or reimbursement of the Products proved to be defective, without indemnification or compensation relating to transport or labour costs to be due to the Client. No responsibility or liability shall be accepted for any statement, representation, warranty or otherwise made by any of SG PAM BAT representative, agent or distributors.

Article 10 - INDUSTRIAL PROPERTY

The plans, models, studies, results of trials, catalogs, notices and all commercial and technical documents disseminated on any support whatsoever, by SG PAM BAT are the exclusive property of SG PAM BAT. As a result, the Client is prohibited from making any copy whatsoever without SG PAM BAT's prior agreement.

Article 11 - MANUFACTURE - RECOMMENDATION

11.1 The weights and dimensions of Products

indicated on SG PAM BAT's documents are theoretical in value. SG PAM BAT reserves the right to make any modification to the information given in its documentation.

11.2 The documents regarding the handling, storage, fitting, use and maintenance of Products are provided by SG PAM BAT free of charge, at the Client's request. The Client remains solely responsible for compliance with the health and safety conditions of these various operations and the implementation of the Products according to industry standards.

SG PAM BAT reserves the right to modify the data given in its documentation at any time. It is the Client's responsibility to verify their validity with SG PAM BAT.

Article 12 - PACKAGING

12.1 The Products' packaging is designed so as to satisfy the requirements of transportation.

12.2 Packaging and dunnage not billed for by SG PAM BAT will be recovered upon delivery.

Article 13 - CONFORMITY OF EXPORTING CONTROLS

The Client undertakes to respect all applicable laws, particularly those concerning export controls. If, at any time, a new law or regulation enters into force rendering the execution of SG PAM BAT's obligations impossible or illegal, SG PAM BAT shall be entitled to cancel the order and terminate the contractual relationship, without any liability with regard to the Client.

Article 14 - PERSONAL INFORMATION

14.1 SG PAM BAT, as a controller, carries out a computerised processing of its clients personal information to place orders and make deliveries.

14.2 Personal information collected in this context (Client's company name, first and last name of SG PAM BAT's contact at the Client's, email address, business telephone or fax number) is strictly necessary for the T&Cs execution and enable SG PAM BAT to manage the order, delivery, invoicing and collection.

14.3 Personal information is kept for the entire duration of the commercial relationship and within the limits of the applicable laws.

14.4 SG PAM BAT's customer service, commercial, invoicing and collection departments, as well as its subcontractors responsible for delivery and sending invoices, receive this data.

GENERAL TERMS & CONDITIONS OF SALE

14.5 In accordance with applicable regulations regarding personal information protection, the Client has a right to access, to correct, to erase and to object to the use of his or her personal information, which the Client may exercise, by sending an email to: privacycontact.sgpambatiment.fr@saint-gobain.com, or by writing to : SAINT-GOBAIN PAM BÂTIMENT - Privacy Correspondent - 21 avenue Camille Cavallier, 54700 Pont-à-Mousson, France.

14.6 For more information about the way SG PAM BAT processes personal information, the Client may consult the web page «Your data and your rights» on SG PAM BAT's websites: www.pambatiment.fr (France website) and www.pambuilding.com (Export website).

14.7 If the Client considers, after having contacted SG PAM BAT, that his/her rights are not respected or that the processing of his/her personal information by SG PAM BAT does not comply with the applicable rules, the Client shall be entitled to file a claim with the French personal data protection supervisory authority (CNIL).

Article 15 - CONFIDENTIALITY

The Client undertakes not to disclose to a third party, in whole or in part, any document, data, or information exchanged, in any form and of any nature whatsoever relating to the order and/or the Products without the prior written consent of SG PAM BAT. This commitment shall apply for the entire duration of the order and for five (5) years from the last delivery of Products under said order.

Article 16 - FORCE MAJEURE

16.1 SG PAM BAT is not responsible for cases of force majeure. Force majeure is understood to mean any cause independent of the will of SG PAM BAT, which would render the performance of its contractual obligations impossible, and affect the manufacture, shipping and delivery of Products. Cases of force majeure are considered to include disruptions to production and/or delivery resulting from a war (declared or not), strike, lock-out, accident, fire, flooding, natural disaster, epidemics, pandemics, interruption or delay in delivery, shortage of materials and/or raw materials, embargoes, and settlements, of any nature whatsoever.

16.2 In the event of force majeure, SG PAM BAT shall have a reasonable extra period of time in which to execute its obligations.

Article 17 - APPLICABLE LAW - ALLOCATION OF JURISDICTION

In the event of a dispute as to the formation, performance or interpretation of the sales contract, the Nancy courts shall be solely competent even in case of multiple defendants, guarantee claims or proceedings in chambers. These T&Cs shall be subject to French law to the exclusion of its conflict-of-law rules.



PAM Building

Sales enquiries:

+33 (0) 383 807 650 / 653 / 654

Technical enquiries:

tcbatiment.sgpam@saint-gobain.com

Visit our website:

www.pambuilding.com

SIMPLE IDEAS SUSTAINABLE RESULTS



10 YEARS
SYSTEM WARRANTY

100% PAM Building System - 100% Guaranteed Performances

Only the exclusive combination of PAM Building products (pipes, fittings, couplings) and the respect of the implementation rules guarantees you results in accordance with the test reports from PAM Building and allows you to benefit from the 10 years warranty.



PAM Building

21 avenue Camille Cavalier - BP 129 • 54705 • PONT-À-MOUSSON Cedex • France

Tel : +33(0)3 83 80 67 89

www.pambuilding.com